



# REMOTE-CONTROL MACHINES FARM

# EXPERIMENTS



# 7447

355 PCS

6+



BUILD 4 TRACTOR ATTACHMENTS



Cultivator



Disc Harrow



Hay Rake



Seeder



BUILD REMOTE-CONTROLLED MODELS OF HEAVY-DUTY FARM VEHICLES

8 MODELS TO BUILD



## TABLE OF CONTENTS

### TIP!

You will find additional information in the "Check it out" sections on pages 15, 19, 23, 27, 32, 51, 58, and 65.



**Safety Information** ..... Inside front cover

**Table of Contents** ..... 1

**Safety Information** ..... 2

**Kit Contents** ..... 3

**Tips and Tricks** ..... 4

### Introduction

**Agriculture and Agricultural Engineering** ..... 5

**Tractors** ..... 6

In this section, you can build a tractor and four different attachments for the tractor. You will also learn about how each attachment works and why it is important in farming.

#### The models:

**Tractor** ..... 6

**Disc Harrow** ..... 16

**Cultivator** ..... 20

**Seeder** ..... 24

**Hay Rake** ..... 28

**Combine Harvester** ..... 33

Build a combine harvester and learn how it is used on a farm to harvest crops.

#### The model:

**Combine Harvester** ..... 33

**Farm Truck** ..... 52

Build a farm truck, which is used to move materials around a farm, and learn about how farmers use remote sensing technology.

#### The model:

**Farm Truck** ..... 52

**Windrower** ..... 59

Build a windrower and learn about how new technologies, such as drones, are being used on farms.

#### The model:

**Windrower** ..... 59

### TIP!

Above each set of assembly instructions, you will find a teal bar:

»» It shows you the difficulty level for the model's assembly:



easy

medium

hard

## SAFETY INFORMATION

## Safety Information

**Warning! Not suitable for children under 3 years. Choking hazard — small parts may be swallowed or inhaled.**

**Store the experiment material and assembled models out of the reach of small children.**

**The models are intended for indoor use. Do not use your models in a sandbox.**

**Keep packaging and instructions as they contain important information.**

## Safety for Experiments with Batteries

»» The wires are not to be inserted into socket-outlets. Never perform experiments using household current! The high voltage can be extremely dangerous or fatal!

»» To operate the models, you will need eight AA batteries (1.5-volt, type AA/LR6), which could not be included in the kit due to their limited shelf life.

»» The supply terminals are not to be short-circuited. A short circuit can cause the wires to overheat and the batteries to explode.

»» Different types of batteries or new and used batteries are not to be mixed.

»» Do not mix old and new batteries.

»» Do not mix alkaline, standard (carbon-zinc), or rechargeable (nickel-cadmium) batteries.

»» Batteries are to be inserted with the correct polarity. Press them gently into the battery compartments. See page 4.

»» Always close battery compartments with the lid.

»» Non-rechargeable batteries are not to be recharged. They could explode!

»» Rechargeable batteries are only to be charged under adult supervision.

»» Rechargeable batteries are to be removed from the toy before being charged.

»» Exhausted batteries are to be removed from the toy.

»» Dispose of used batteries in accordance with environmental provisions, not in the household trash.

»» Be sure not to bring batteries into contact with coins, keys, or other metal objects.

»» Avoid deforming the batteries.

As all of the experiments use batteries, have an adult check the experiments or models before use to make sure they are assembled properly. Always operate the motorized models under adult supervision. After you are done experimenting, remove the batteries from the battery compartments. Note the safety information accompanying the individual experiments or models!

## Notes on Disposal of Electrical and Electronic Components

The electronic components of this product are recyclable. For the sake of the environment, do not throw them into the household trash at the end of their lifespan. They must be delivered to a collection location for electronic waste, as indicated by the following symbol:

Please contact your local authorities for the appropriate location.



## Dear Parents and Supervising Adults,

Before starting the experiments, read through the instruction manual together with your child and discuss the safety information. Check to make sure the models have been assembled correctly, and assist your child with the experiments.

**We hope you and your child have a lot of fun with the experiments!**

### FCC Part 15 Statement

This device complies with Part 15 of the FCC Rules. Operation is subject to the following two conditions: (1) this device may not cause harmful interference, and (2) this device must accept any interference received, including interference that may cause undesired operation.

Fcc warning: Changes or modifications not expressly approved by the party responsible for compliance could void the user's authority to operate the equipment.

Note for RC car with receiver: This equipment complies with FCC radiation exposure limits set forth for an uncontrolled environment and meets the FCC radio frequency (RF) Exposure Guidelines. This equipment has very low levels of RF energy that it deemed to comply without maximum permissive exposure evaluation (MPE). But it is desirable that it should be installed and operated keeping the radiator at least 20cm or more away from person's body.

Note for hand-held RC unit: This equipment complies with FCC radiation exposure limits set forth for an uncontrolled environment and meets the FCC radio frequency (RF) Exposure Guidelines. This equipment has very low levels of RF energy that are deemed to comply without testing of specific absorption ratio (SAR).

### IC Statement

This device complies with Industry Canada's license-exempt RSSs. Operation is subject to the following two conditions:

- (1) This device may not cause interference; and
- (2) This device must accept any interference, including interference that may cause undesired operation of the device.

*Son fonctionnement est soumis aux deux conditions suivantes:*

- (1) Cet appareil ne peut pas provoquer d'interférences et*
- (2) Cet appareil doit accepter toute interférence, y compris les interférences qui peuvent causer un mauvais fonctionnement du dispositif.*

This device complies with the ISED radiation exposure limit set forth for an uncontrolled environment. This device should be installed and operated with minimum distance 20cm between the radiator and your body. This transmitter must not be co-located or operating in conjunction with any other antenna or transmitter.

*Cet équipement est conforme avec l'exposition aux radiations ISED définies pour un environnement non contrôlé. Cet équipement doit être installé et utilisé à une distance minimum de 20 cm entre le radiateur et votre corps. Cet émetteur ne doit pas être co-localisées ou opérant en conjonction avec une autre antenne ou transmetteur.*

### Simplified EU Declaration of Conformity

Gigo hereby declares that the radio communication units, "Remote-Control Machines: Farm" model numbers 7447-W85-A and 7447-W85-B, conform to Directive 2014/53/EU. The complete text of the EU conformity declaration is available at the following Internet address:  
[https://issuu.com/gigotoys/docs/\\_7447-doc](https://issuu.com/gigotoys/docs/_7447-doc)

## KIT CONTENTS

### What's inside your experiment kit:

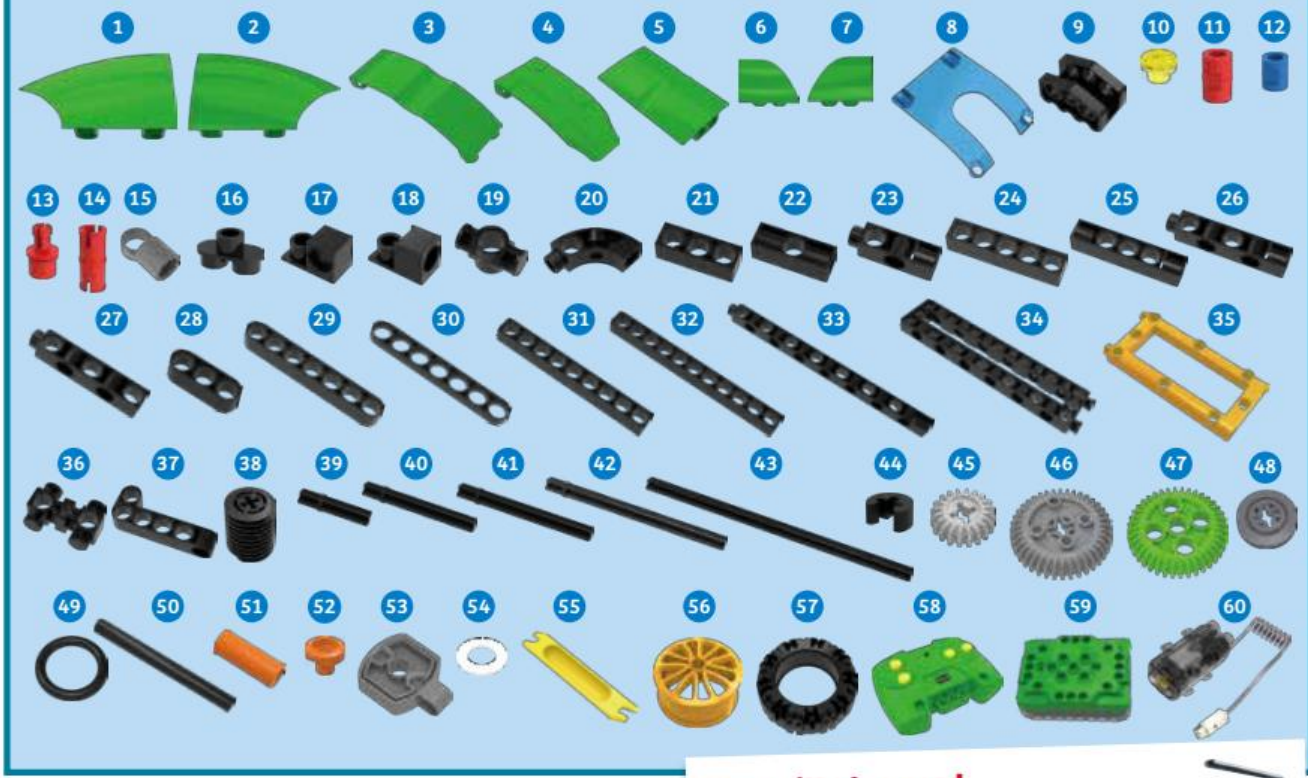

**You will also need:**  
8 x AA batteries (1.5-volt, type AA/LR6)

### Checklist: Find – Inspect – Check off

No.	Description	Qty.	Item No.	No.	Description	Qty.	Item No.
1	C-SHELL A LEFT	1	7392-W10-L1G1	31	C-9 HOLE ROD	5	7407-W10-C1D
2	C-SHELL A RIGHT	1	7392-W10-L2G1	32	C-11 HOLE ROD	8	7413-W10-P1D
3	C-SHELL F	2	7398-W10-C1G1	33	C-15 HOLE DUAL ROD	2	7413-W10-Z1D
4	C-SHELL E	3	7398-W10-C2G1	34	C-3x13 DUAL FRAME	2	7406-W10-A1D
5	C-SHELL J	2	7407-W10-D1G	35	C-5X10 ARCH FRAME	1	7411-W10-E1O
6	C-SHELL I LEFT	2	7407-W10-D2G	36	C-BOLT ROD WITH PINS	9	7406-W10-B1D
7	C-SHELL I RIGHT	2	7407-W10-D3G	37	C-5 HOLE L SHAPE ROD	9	7406-W10-B2D
8	C-SHELL G	1	7396-W10-I1B	38	C-WORM GEAR	2	7344-W10-A1D
9	C-GRIPPER	1	7411-W10-G1D	39	C-35mm AXLE II	4	7413-W10-O1D
10	C-SHORT BUTTON FIXER	8	7061-W10-W1TY	40	C-60mm AXLE II	5	7413-W10-M1D
11	C-LONG PEG	10	7061-W10-C1R	41	C-70mm AXLE II	6	7061-W10-Q1D
12	B-SHORT PEG	100	7344-W10-C2B	42	C-100mm AXLE II	9	7413-W10-L2D
13	C-AXLE	1	7026-W10-H1R	43	C-150mm AXLE I	1	7026-W10-P1D
14	C-20mm AXLE CONNECTOR	8	7413-W10-T1R	44	C-AXLE FIXING	2	3620-W10-A1D
15	C-KNUCKLE FOR AXLE	21	7410-W10-C1S	45	C-20T GEAR	12	7026-W10-D2S
16	C-TWO-IN-ONE CONVERTER	2	7061-W10-G1D	46	C-40T GEAR	7	7346-W10-C1S
17	C-LATERAL CONVERTER	4	7061-W10-X1D	47	C-40T SPINDLE GEAR	5	7408-W10-D1G
18	C-FRONT CONVERTER	4	7061-W10-Y1D	48	C-OD23mm PULLEY	1	7344-W10-N3S1
19	C-1 HOLE CONNECTOR	29	7430-W10-B1D	49	C-OD26 O-RING	1	R12-08S
20	C-BENDED ROD	2	7061-W10-V1D	50	C-OD8x80mm TUBE	2	7337-W16-A1D
21	C-3 HOLE ROD	1	7026-W10-Q2D	51	C-TUBE BOLT	2	7404-W10-G1O
22	C-3 HOLE ROD FRONT CLOSED	6	7026-W10-X1D	52	C-TUBE BOLT CAP	2	7404-W10-G2O
23	C-3 HOLE DUAL ROD	6	7413-W10-Y1D	53	C-PONTOON BASE	2	7398-W10-E1S
24	C-5 HOLE ROD	2	7413-W10-K2D	54	C-WASHER	3	R12#3620
25	C-5 HOLE ROD FRONT CLOSED	1	7413-W10-R1D	56	B-PEG REMOVER	1	7061-W10-B1Y
26	C-5 HOLE DUAL ROD	2	7413-W10-X1D	56	C-TURBO TIRE RIM	4	7407-W10-B1O
27	C-5 HOLE DUAL ROD BOTTOM CLOSED	3	7413-W10-W1D	57	C-TRUCK TIRE	4	7408-W10-C1D
28	C-3 HOLE ROUND ROD	5	7404-W10-C1D	58	C-RF REMOTE CONTROLLER	1	7447-W85-A
29	C-7 HOLE ROUND ROD	5	7404-W10-C2D	59	C-RF RECEIVER	1	7447-W85-B
30	C-7 HOLE PROLATE ROD	5	7404-W10-C3D	60	C-50X PLANETARY GEARBOX	2	7447-W85-C

## TIPS AND TRICKS

### GENERAL BUILDING TIPS PEGS AND CONNECTORS



Take a careful look at the different assembly components. Red long pegs, blue short pegs, axle connectors, and axles all look pretty similar at first glance. When you assemble the models, it's important to use the right ones. The blue short pegs are shorter than the red ones.

### CONNECTING FRAMES AND RODS

Use the pegs to connect frames and rods.

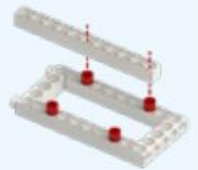

### AXLES

The building system contains axles (also called shafts) of various lengths. When assembling the model, always be sure that you're using the right one.



### PEG REMOVER

When you want to take your model apart again, you will need the peg remover. Use the narrow end of the peg remover to remove the pegs. You can use the wide end to pry out axles.

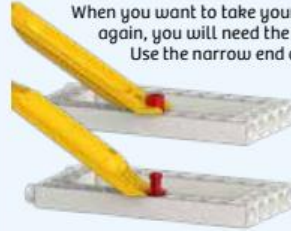

### PULLEYS AND GEARS

If pulleys or gears are mounted too tightly against other components, they can be hard to turn. If you leave a gap of about 1 mm between the gear or pulley and an adjacent component, it will turn easily. In some of the models, a washer is used to ensure this kind of spacing.

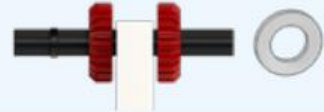

Here are a few tips for assembling and using the models. Read them carefully before starting.

### A. Place the tires on the wheels

Place a tire over each of the four wheels before you build the first model.



### B. Batteries in RF remote controller

Open the battery compartment by pushing on the tab on the back of the RF receiver and lifting the back panel up. Insert two AA batteries, paying attention to the polarity indicated in the compartment and on the batteries. Close the compartment again.

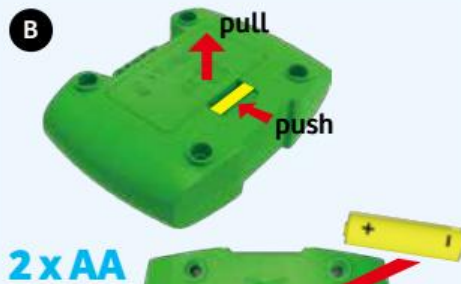

### C. Batteries in RF receiver

Open the battery compartment by pushing on the tab on the bottom of the RF battery box. Insert six AA batteries, paying attention to the polarity indicated in the compartment and on the batteries. Close the compartment again.

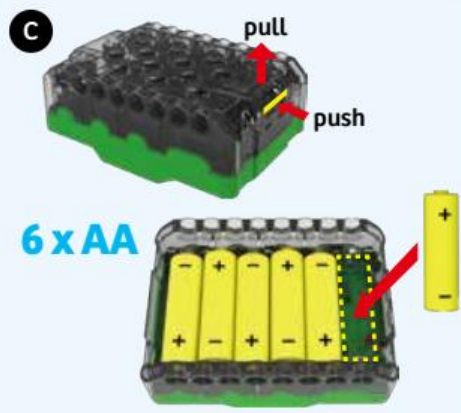

### D. Using the RF remote control

To control a model, turn on both the motor unit and the remote control unit by moving their switches from the "off" position (O) to the "on" position (+). The lights will flash on the RF remote controller and receiver while they establish a connection. Once a connection is established the lights on the receiver will turn off and the light on the remote controller will be solid. If you are using multiple RF remote control units and battery boxes in the same area, set the remote control units to different channels and then establish connections to the battery.

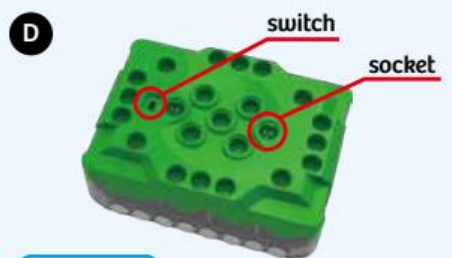

### E. Rc unit & socket

The left side of the RC unit controls the socket on the left side of the battery box. The right side of the RC unit controls the socket on the right side of the battery box.

If you want your model to move in the opposite direction when you press one of the RC unit buttons, you can simply rotate the direction of the plug in the socket 180 degrees.

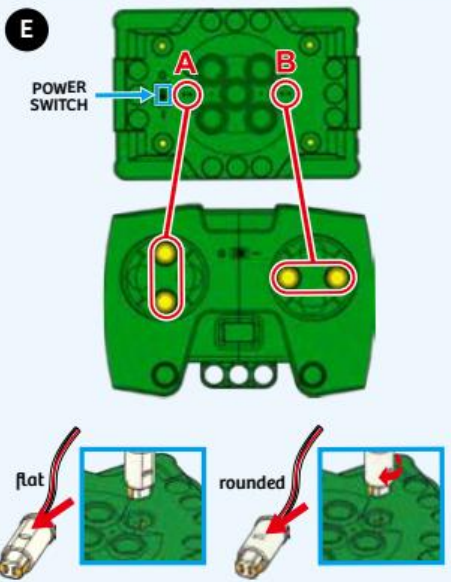
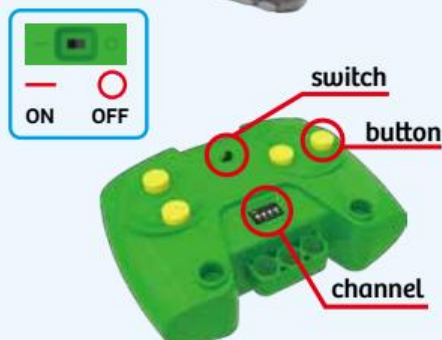

# Agriculture and Agricultural Engineering

Agriculture is the cultivation of crops or the raising of animals for food or raw materials. To make farming tasks easier, farmers use many different tools and specialized equipment. Today, farmers are under increasing pressure to harvest as much as possible from their land due to climate change, population growth, and limited resources. To overcome these challenges, farmers and agricultural engineers have developed new innovations and technologies. In this kit, you will build models of some of these farm vehicles and learn about how they function.





## TRACTOR Model 1

7 x2

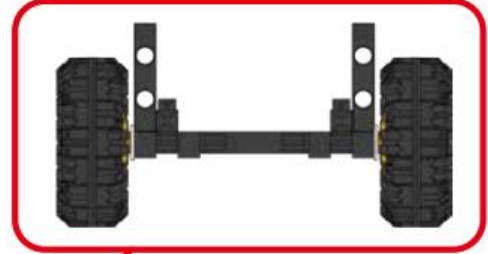
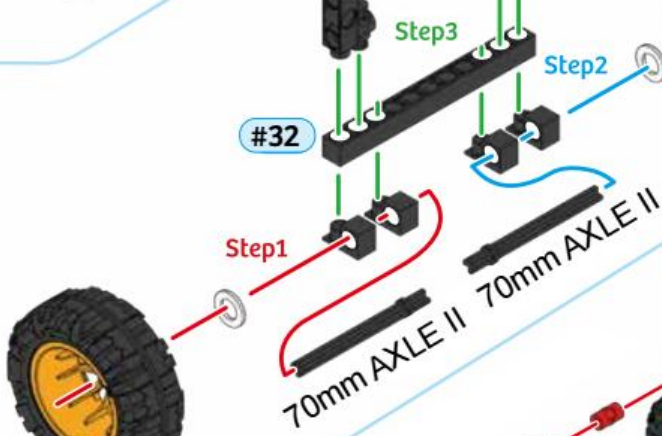
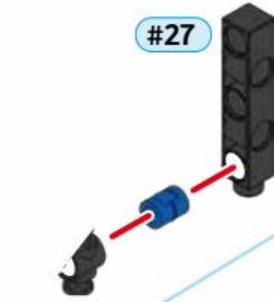

8

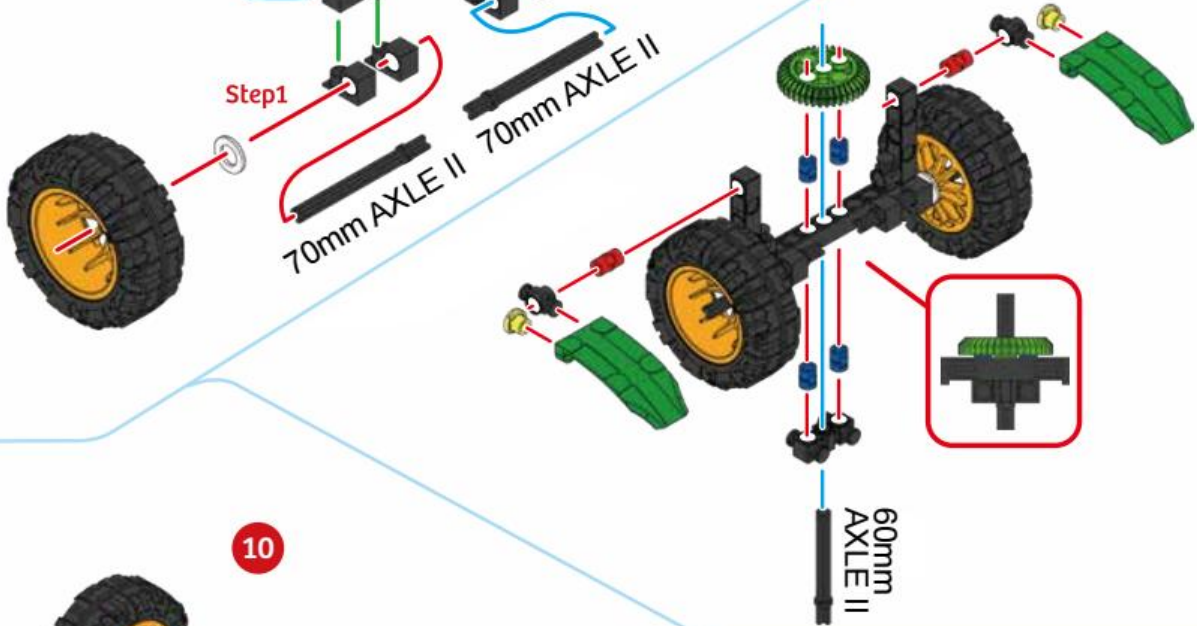

9

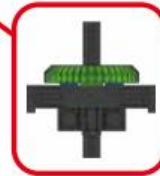

60mm  
AXLE II

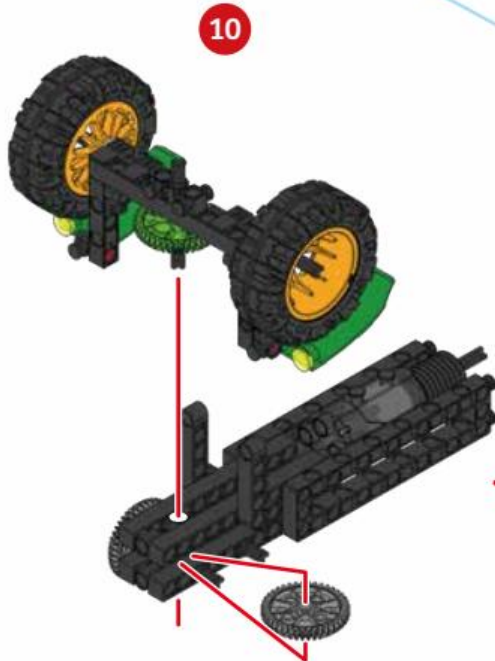

10

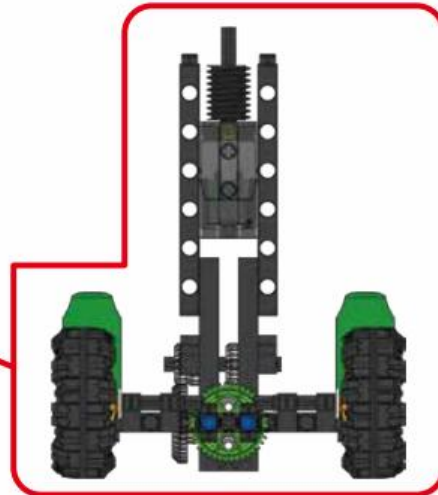



Model 1 TRACTOR

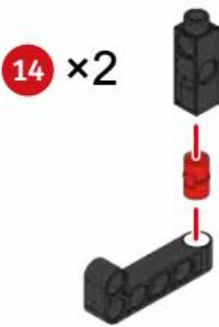
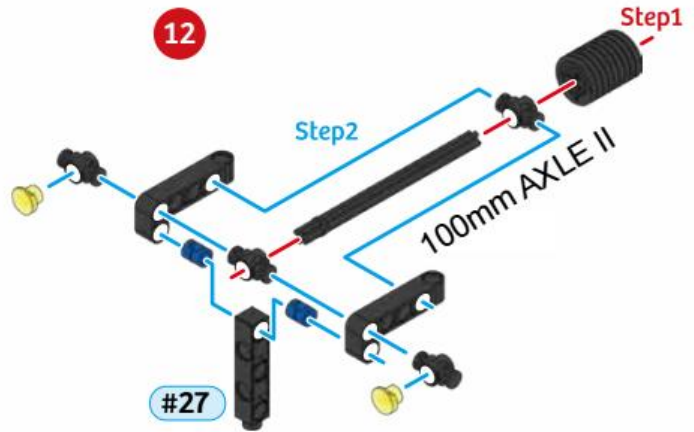
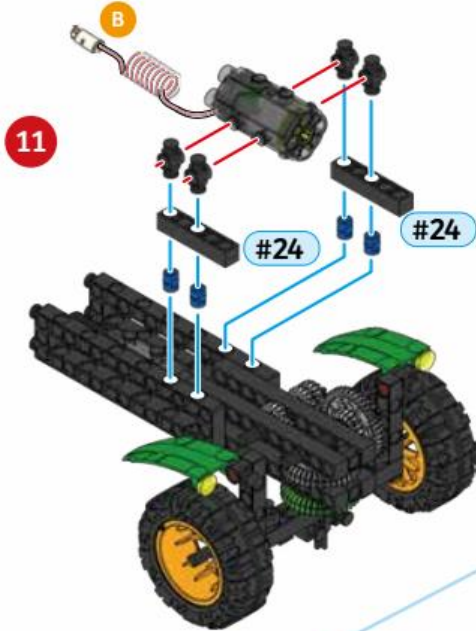

15

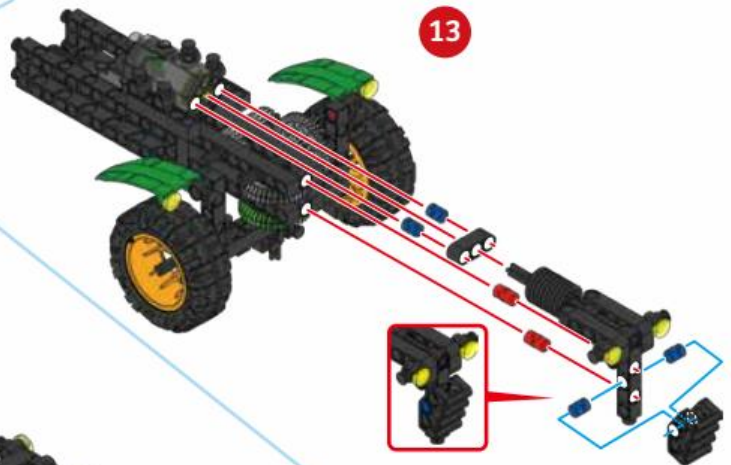
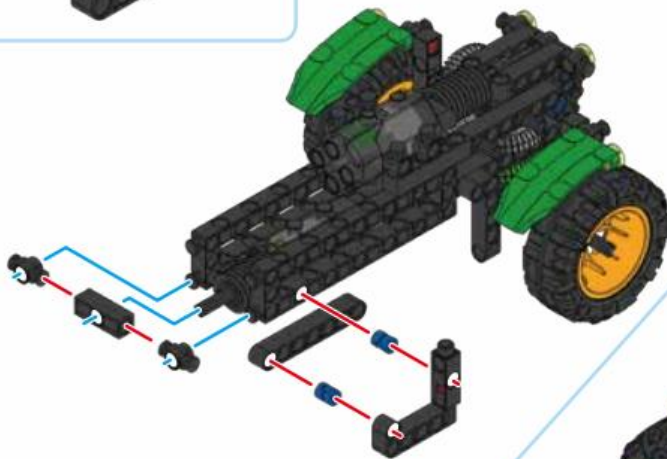

16

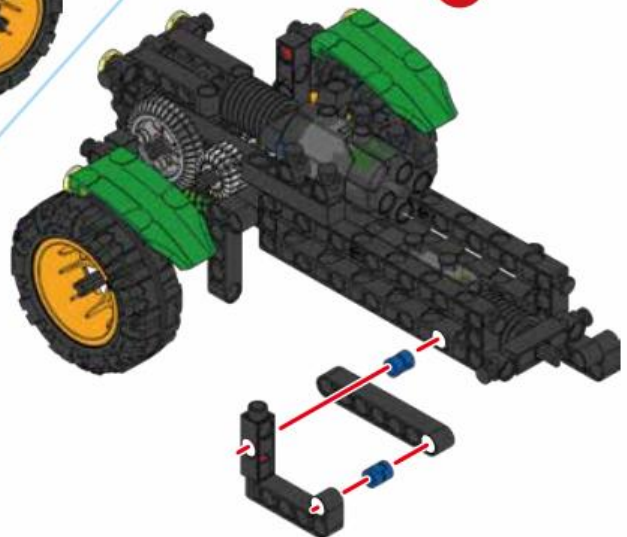

## TRACTOR Model 1

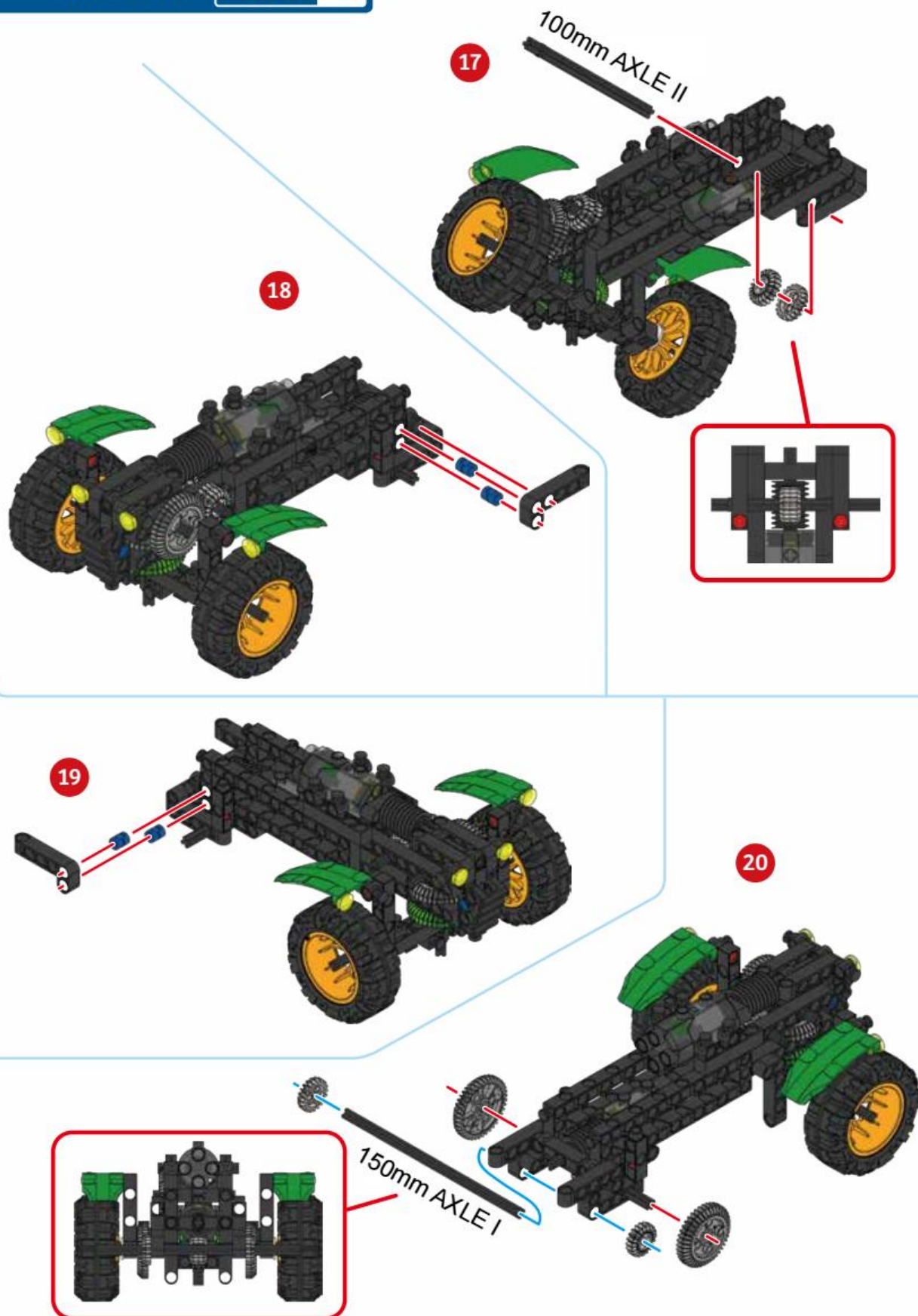

## Model 1 TRACTOR

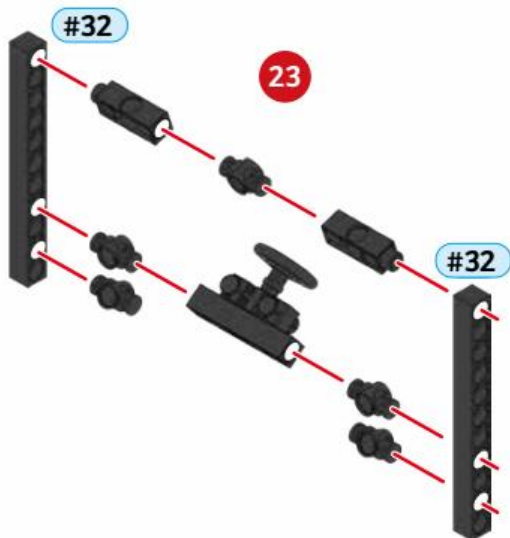
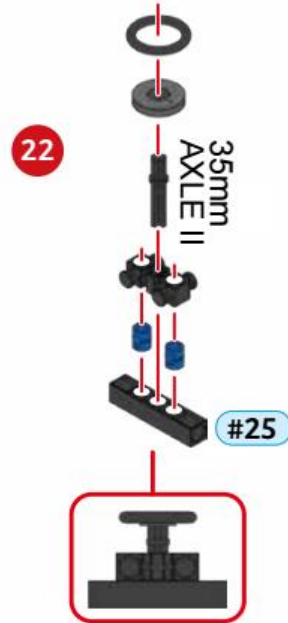
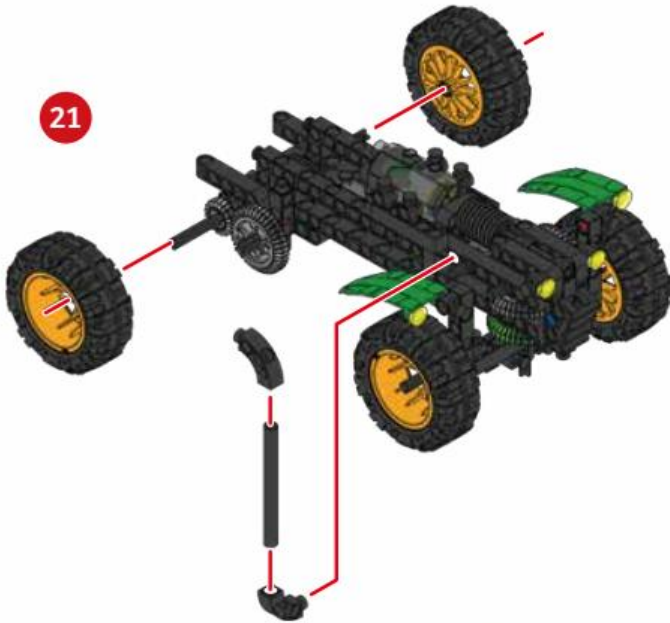

Pass the blue part through before step 3.

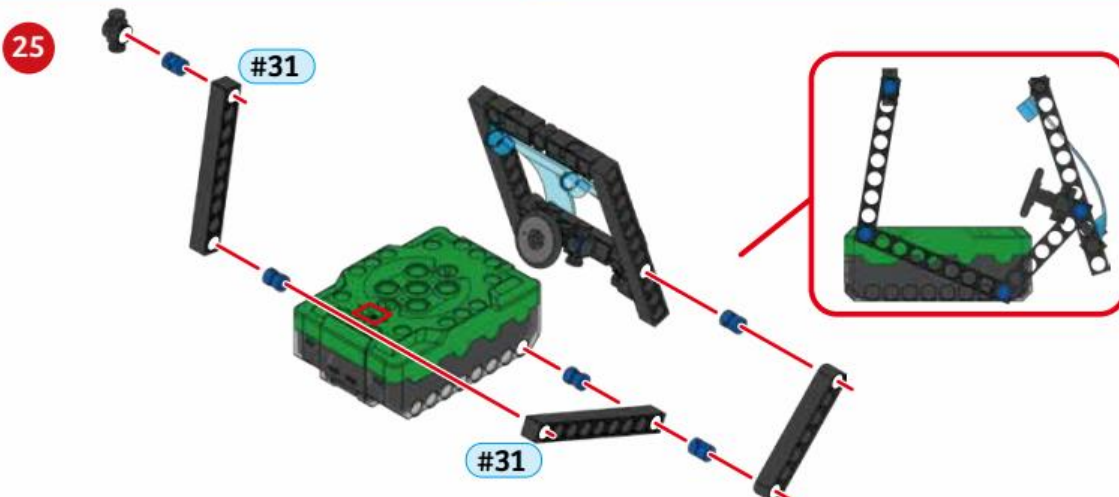
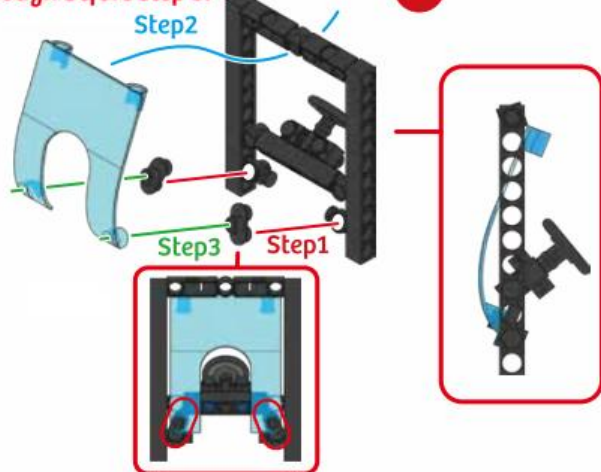

## TRACTOR Model 1

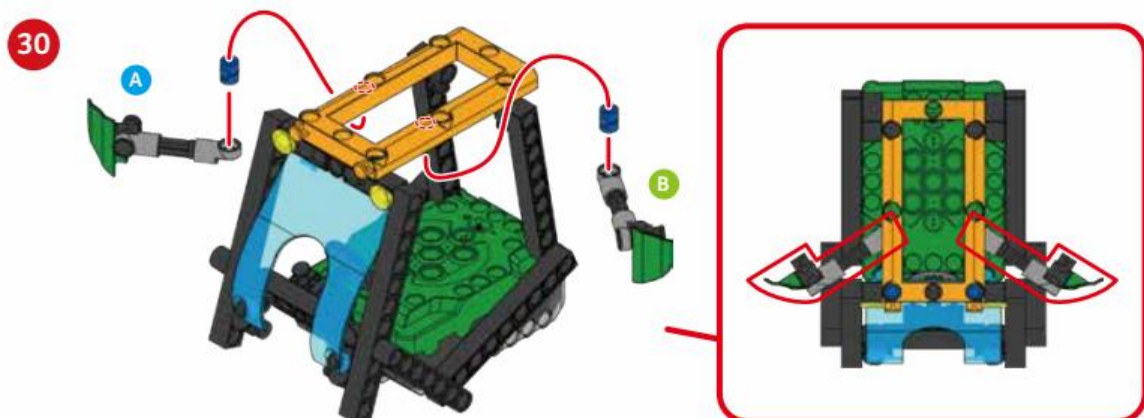
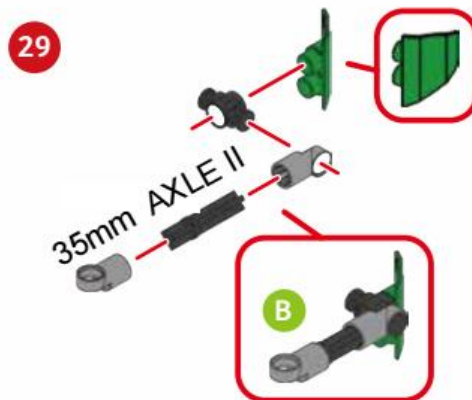
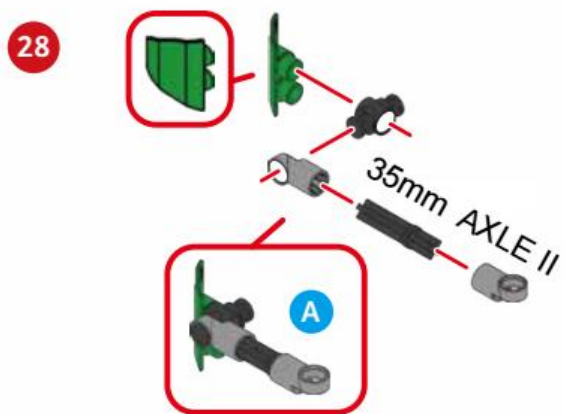
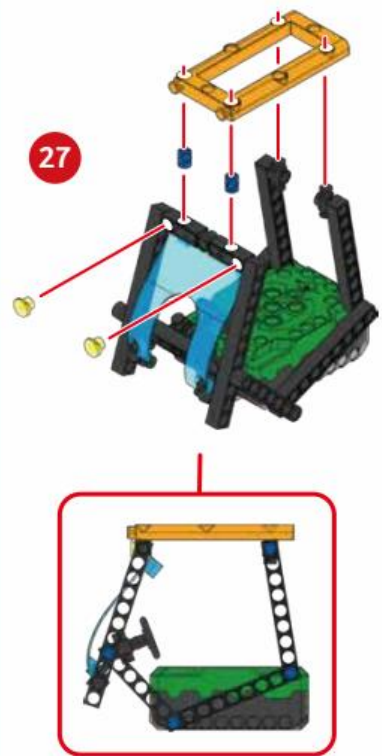
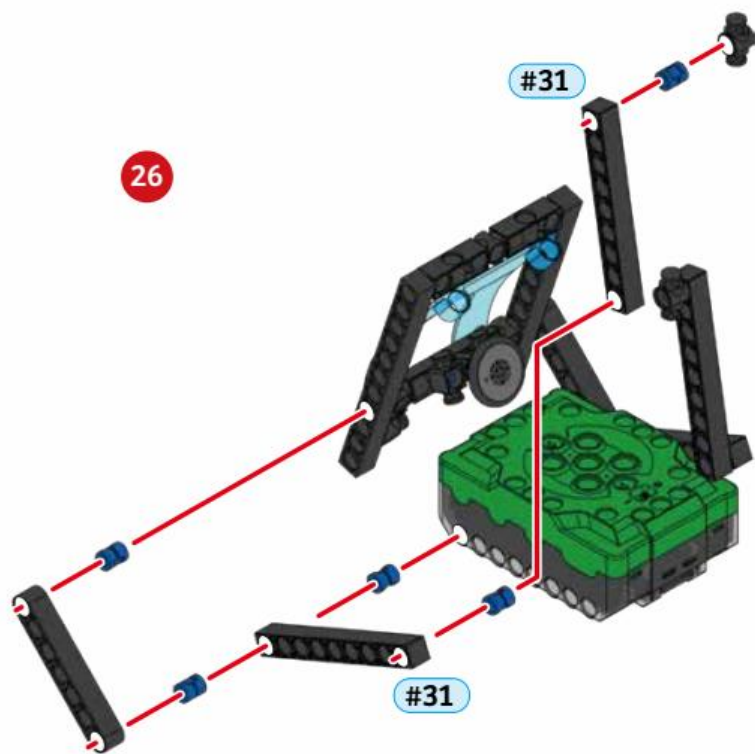



Model 1 TRACTOR

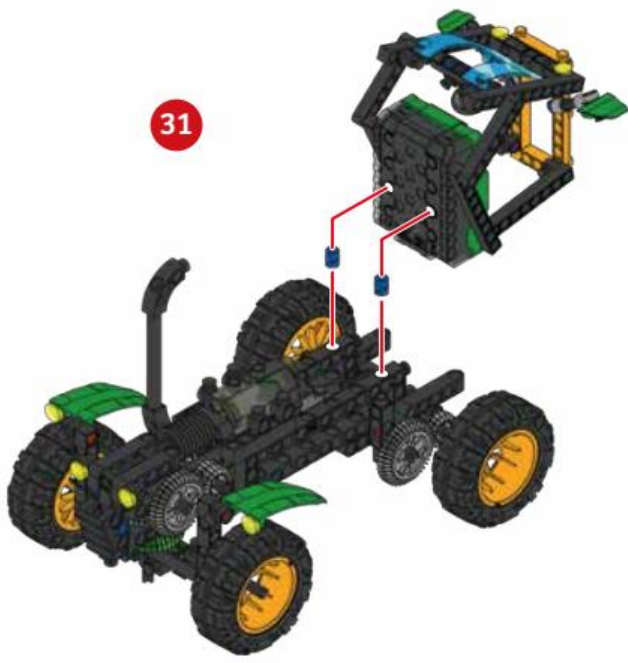

31

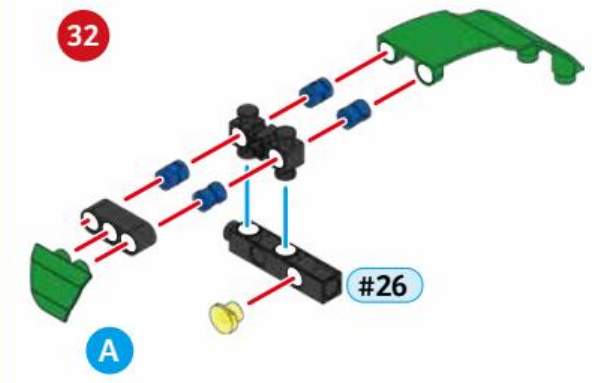

32

A

#26

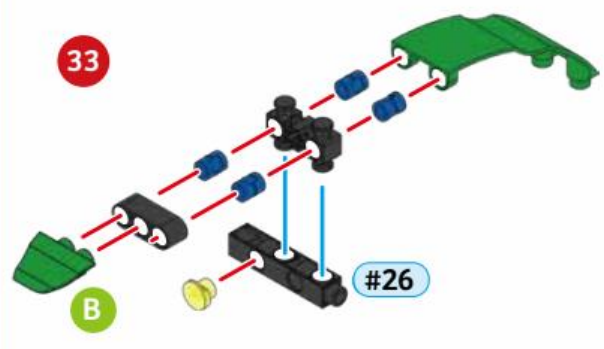

33

B

#26

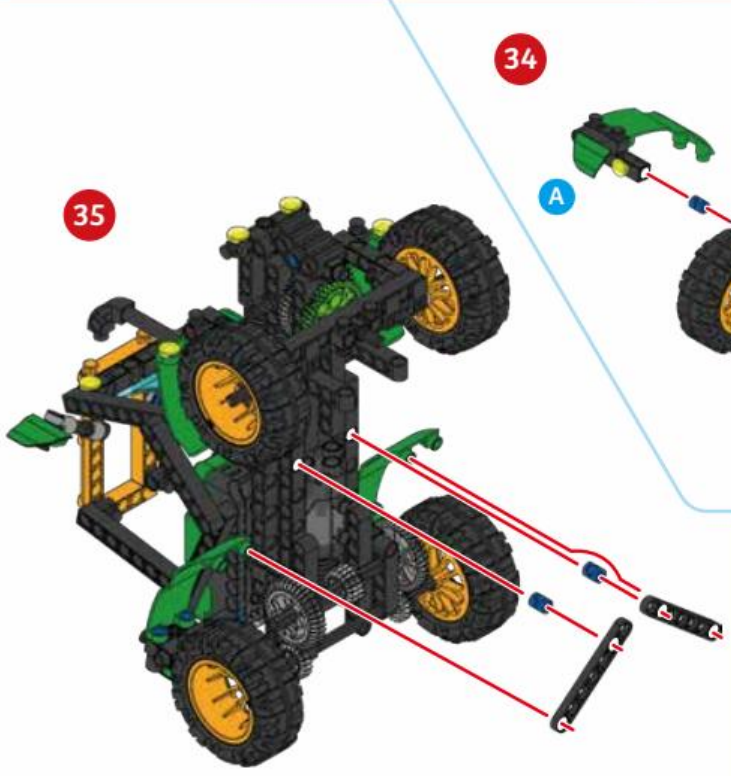

35

34

A

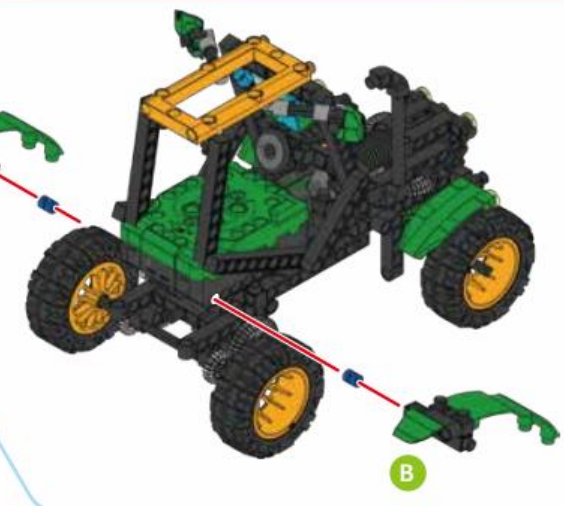

B

36

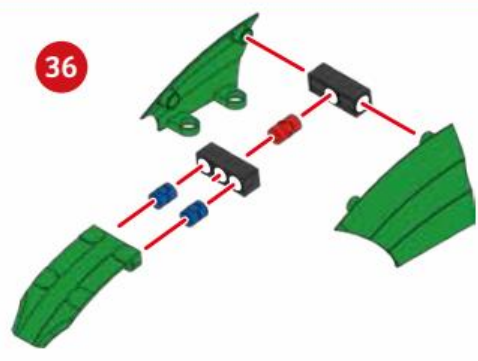

## TRACTOR Model 1

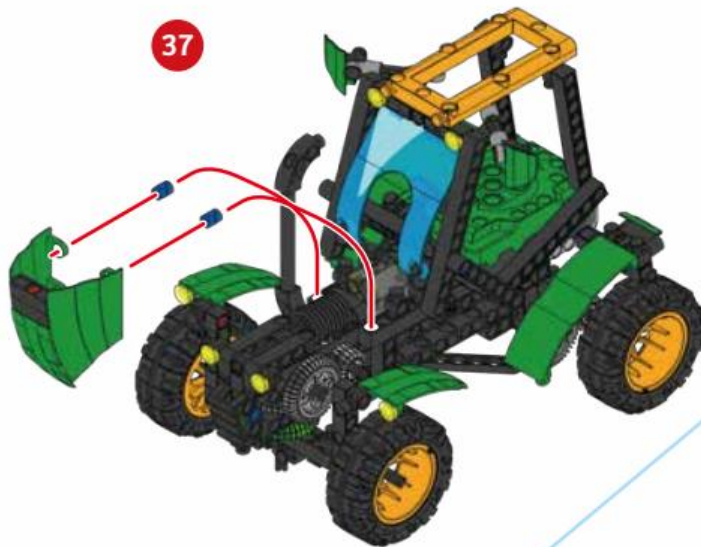

37

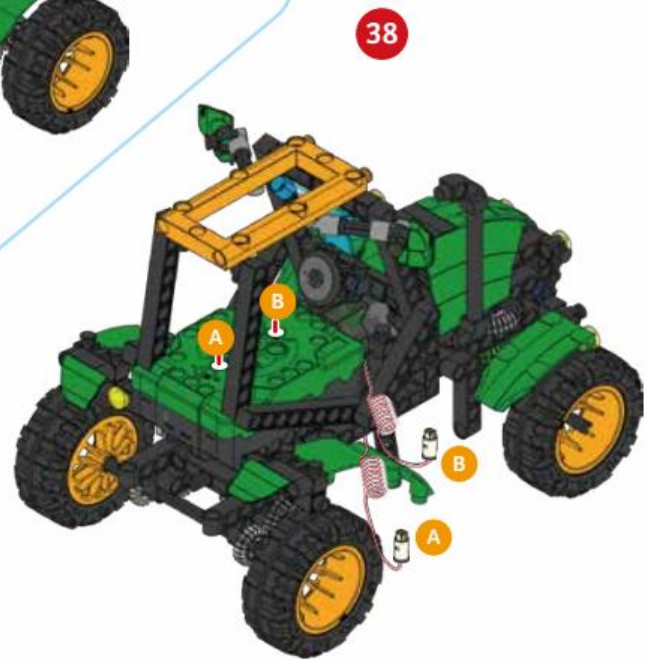

38

### EXPERIMENT 1

## Speeding up and slowing down?

### HERE'S HOW

Measure a set distance on your floor; for example, two feet. Use a stop watch to measure the amount of time that it takes the tractor to travel this set distance. Then use the instructions on page 14 to change the gear ratio of the tractor. Repeat the previous experiment with modified tractor. What happens to the time it takes for the tractor to travel this distance?

Done!



39

## Model 1 TRACTOR

1

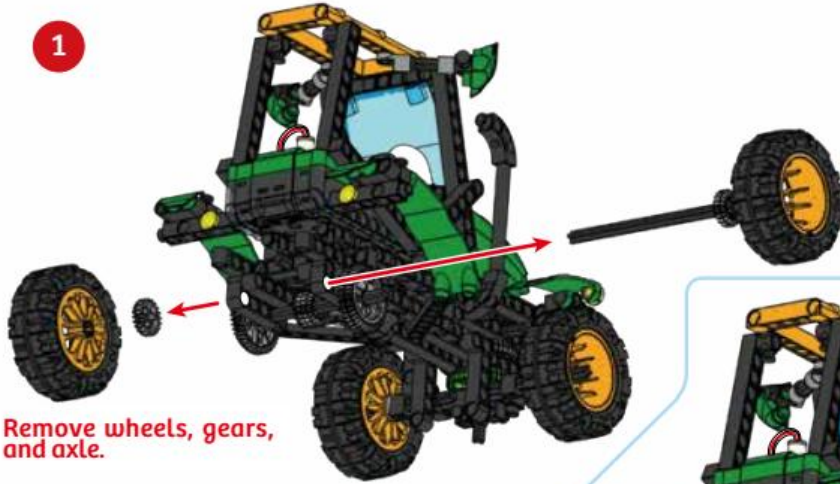

2

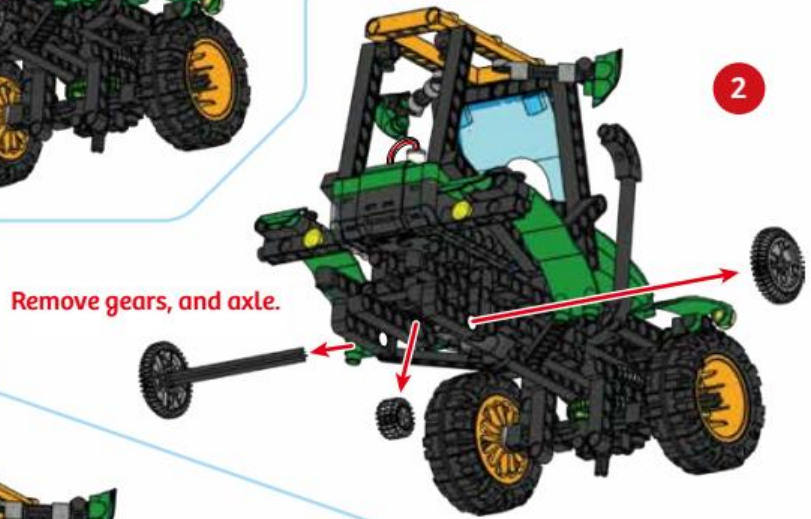

3

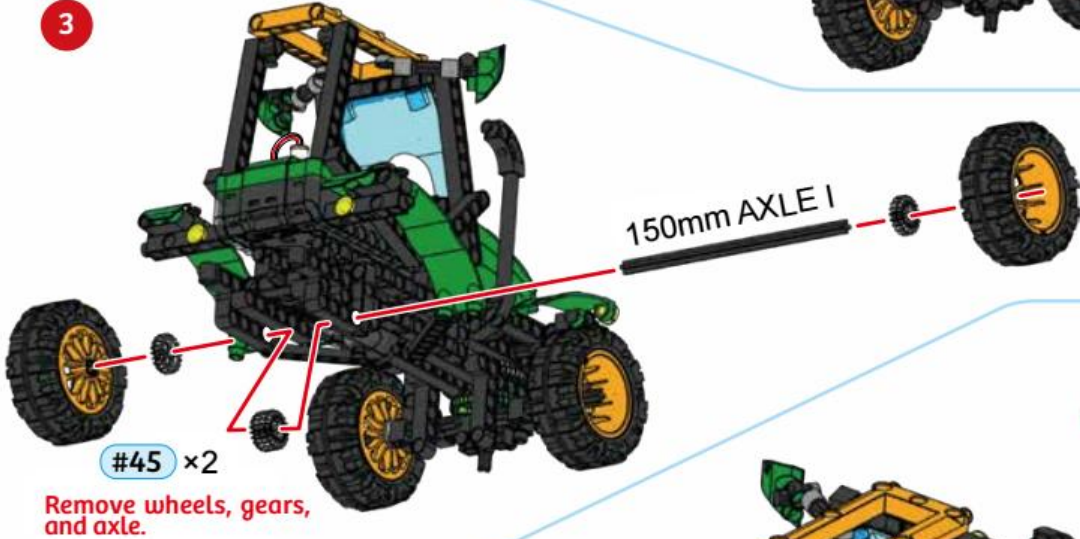

4

Done!



## CHECK IT OUT

### Engines

How do tractors produce enough traction to pull large pieces of machinery through different conditions, such as muddy or sandy soil?

The ability of a tractor to perform work comes from its engine. The types of engine used in tractors and cars are called heat engines, because they convert thermal energy, or the energy from heat, into mechanical energy, or the energy of motion. Heat engines accomplish this by heating up a fluid, called the working fluid

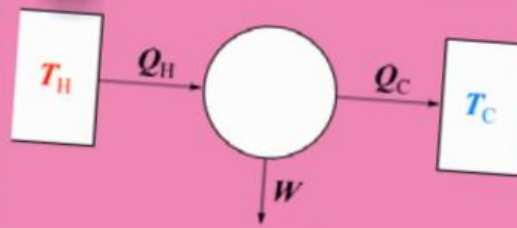

Carnot heat engine



### STEAM ENGINE

The first powered farm machines used **steam engines**. In a steam engine, the working fluid is water, which is heated until it becomes steam.

Water is made up of many very small water molecules. When water is heated into steam, the water molecules move around faster, take up more space, and bump into their container more — increasing the pressure. The steam can then be put into a sealed steam can then container which has only one surface that can move up and down as the steam expands and contracts, turning the thermal energy of the steam into mechanical energy! This sealed container is called a **cylinder** in an engine and the part that moves up and down is called a **piston**.

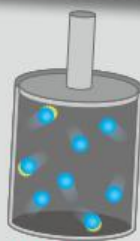

LOW PRESSURE

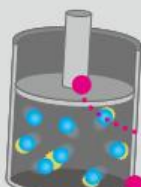

HIGH PRESSURE

Steam engines are **external combustion engines** because the steam is separate from what is used to heat the steam, such as burning coal.

Modern-day tractor engines use internal combustion engines that use a fossil fuel, usually gasoline or diesel. They are called that because fuel is ignited inside the cylinder and, just like the water in a steam engine, the exploding fuel expands, pushing on the piston. This causes the piston to turn the crankshaft, which is used to turn the wheels of the tractor.

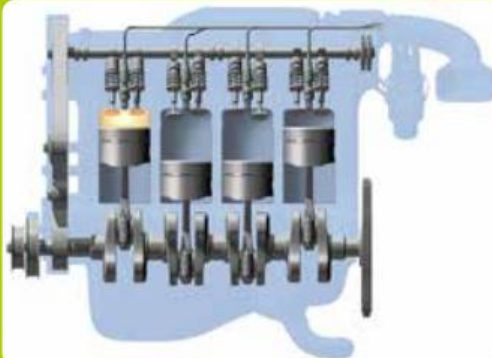



## Model 2 DISC HARROW

### Parts Needed

● ● ● Medium

 11 x2	 14 x1	 18 x2	 19 x1	 28 x1	 33 x2
 36 x5	 37 x1	 42 x3	 45 x3	 46 x2	 47 x4

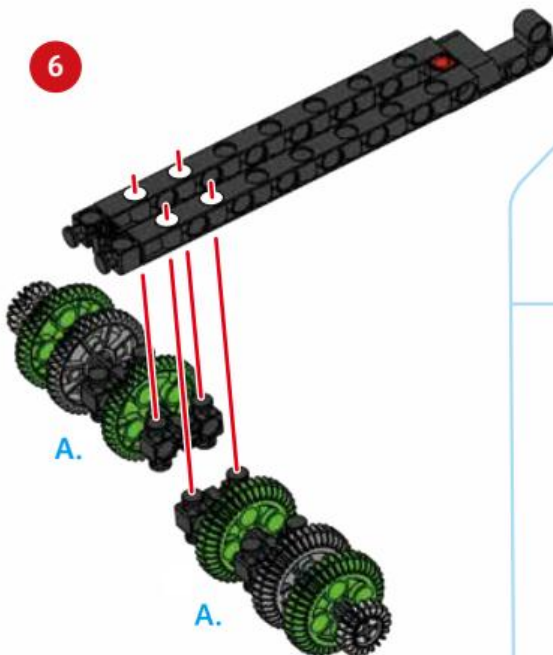
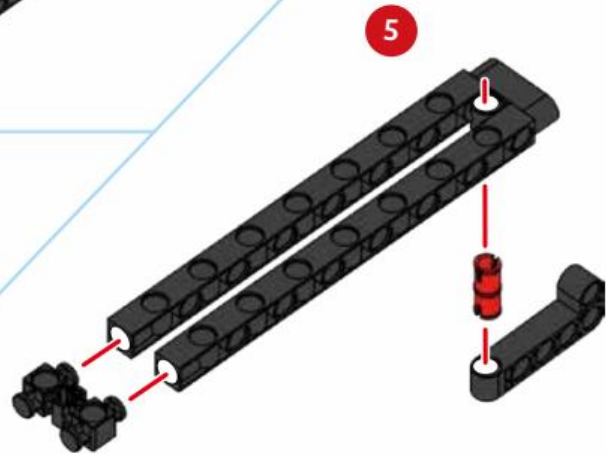
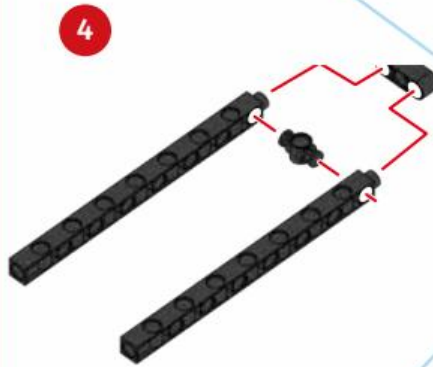
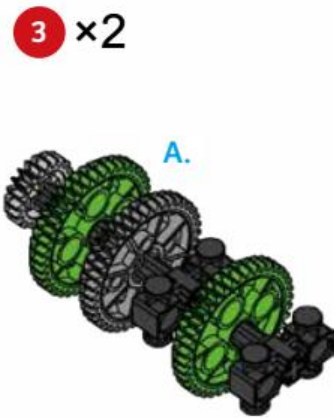
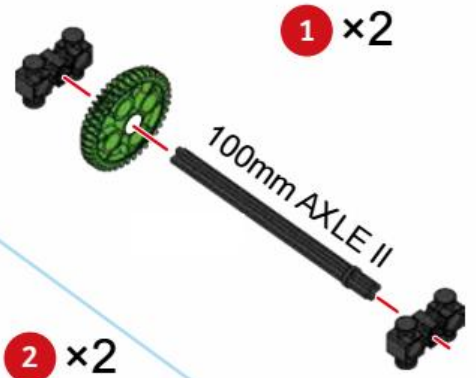

## DISC HARROW Model 2



Attach the disc harrow to the tractor.

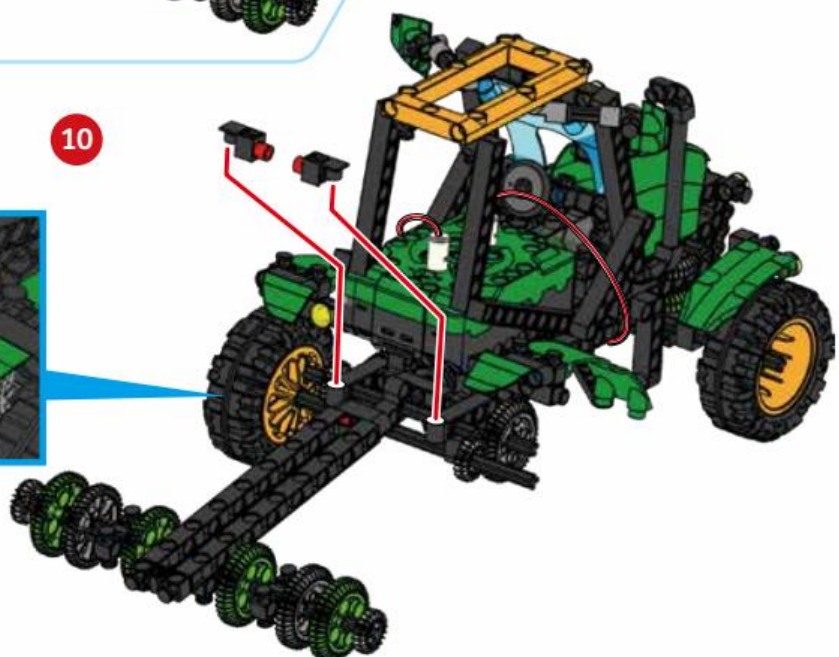
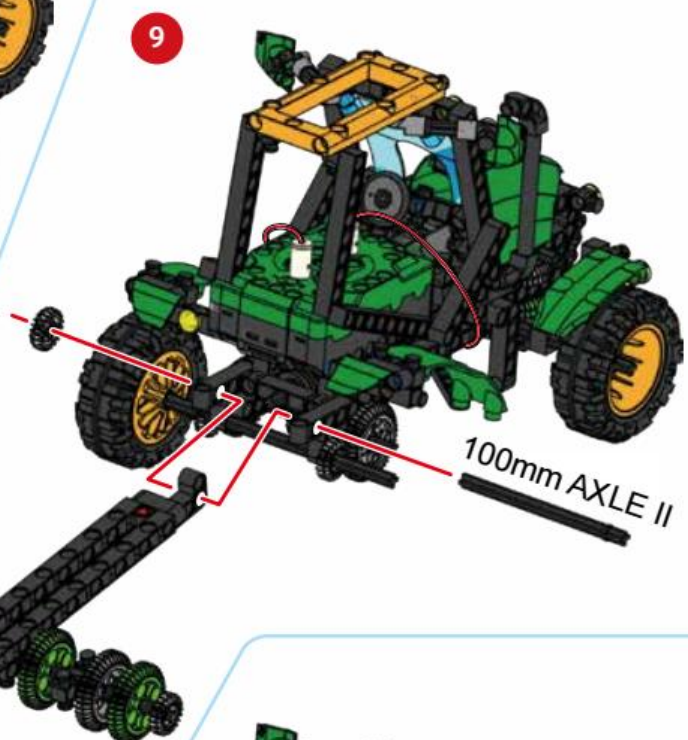

## Model 2 DISC HARROW

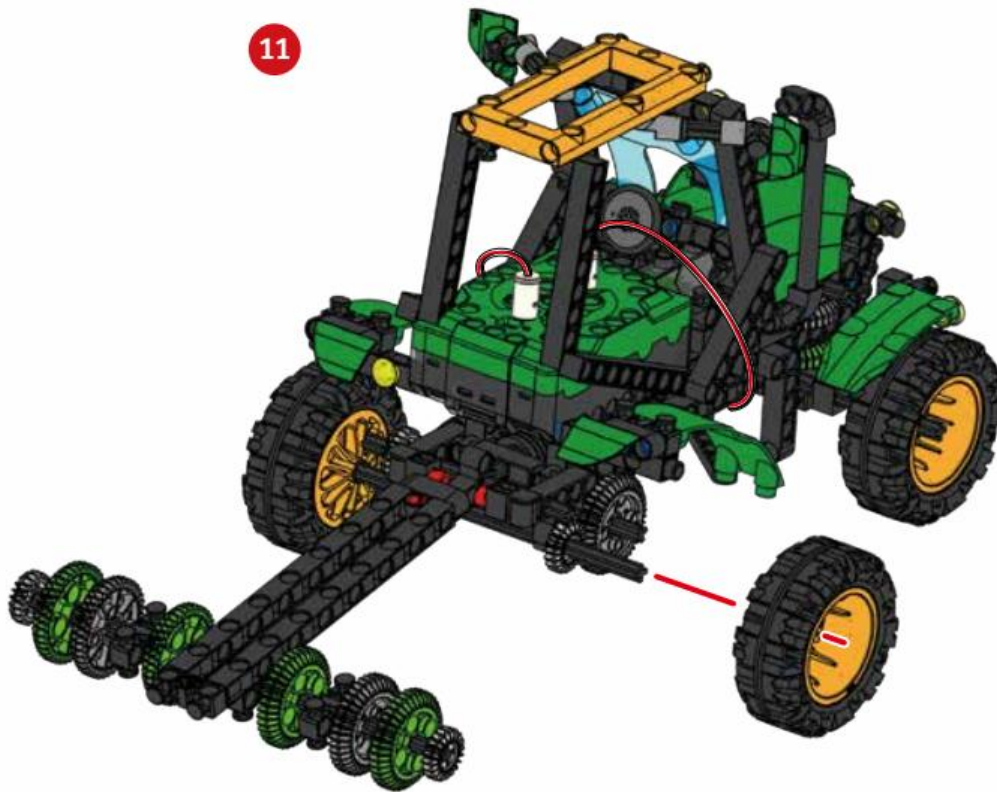

## EXPERIMENT 2

## Tilling soil

## HERE'S HOW

Set up the tractor to drag the disc harrow attachment through a thin layer of fine sand, such as in a sandbox. Flatten the sand and then run the disc harrow attachment through the sand again but with the discs closer together. What do you observe? What happens to the pattern formed by the discs in the sand?

Done!



## CHECK IT OUT

### PREPARING THE SOIL FOR PLANTING

The physical characteristics of soil are important for the growth of plants. Soil consists of small particles of organic matter with spaces in between the particles. The size of these spaces determines the ability of soil to hold and conduct water, nutrients, and air to the roots of plants. If the soil particles are spaced too closely together (a condition called soil compaction) water and air can't pass through the soil easily. Soil compaction also makes it harder for the roots of plants to break through the soil.

Compacted Soil

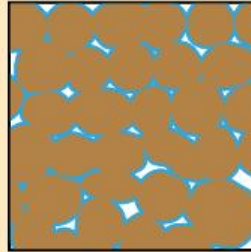

Ideal Soil

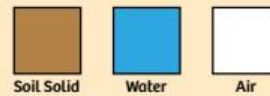
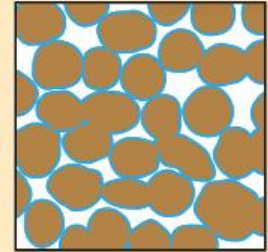

The process of preparing soil for planting is called tilling. The best-known tillage device is the plow. In the U.S. plows have been replaced by tools that use offset discs, similar to ones used by the disc harrow, or chisels. Plowing is done first to provide a deeper tillage, while harrowing is often carried out after plowing to provide a finer finish.

### SIMPLE MACHINES: THE WEDGE

Farm machines, such as tractors and disc harrows, are complex machines. To make it easier to understand and analyze them, you can break them down into a combination of many simple machines that work together. The blade of a plow or the disc of a harrow is a simple machine called a **wedge**. Wedges are used to make splitting, pushing apart, or cutting materials easier. The blade of an axe is another example of a wedge.



### WHAT IS A SIMPLE MACHINE?

A simple machine is a mechanical device that changes the direction or magnitude of a force. A force is simply a push or a pull. A simple machine takes one input force and produces an output force, which is used to do work. Simple machines are used to make doing work easier.

## Model 3 CULTIVATOR

### Parts Needed

● ● ● Easy



1 x4

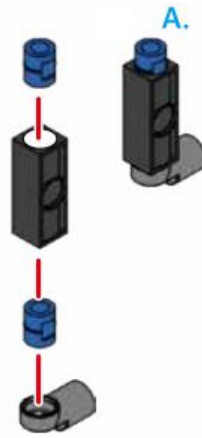

2 x2

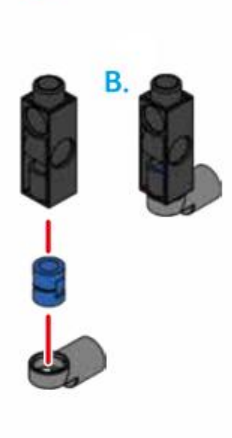

3

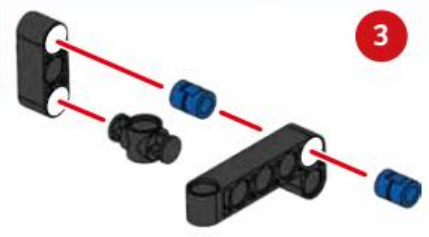

4

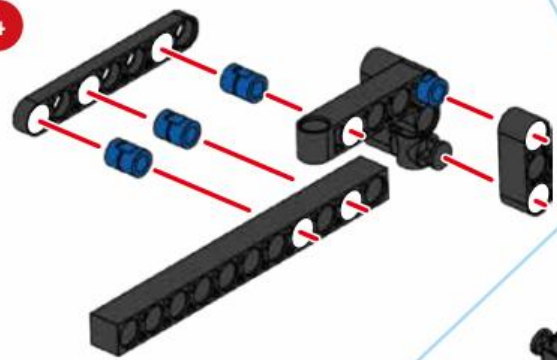

5

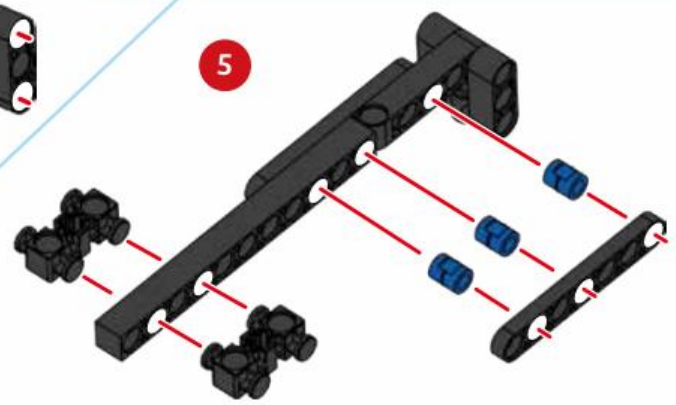

6

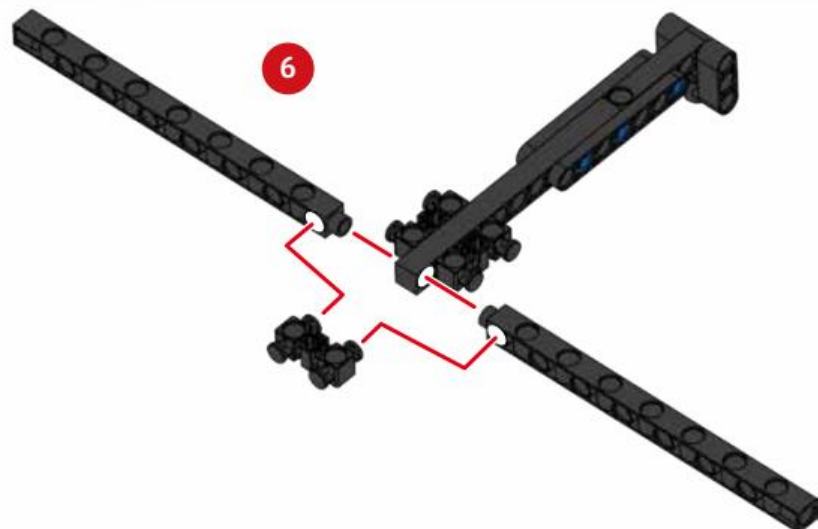

## CULTIVATOR Model 3

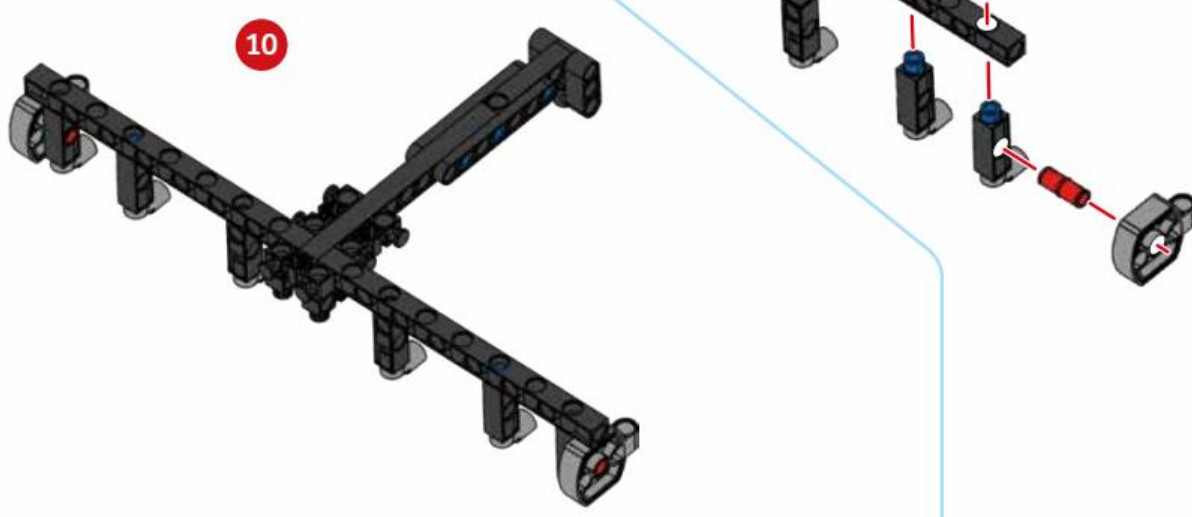
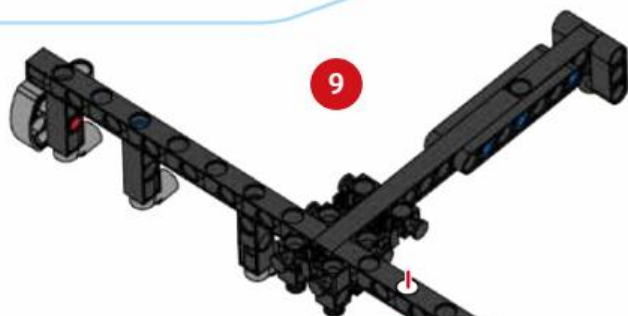
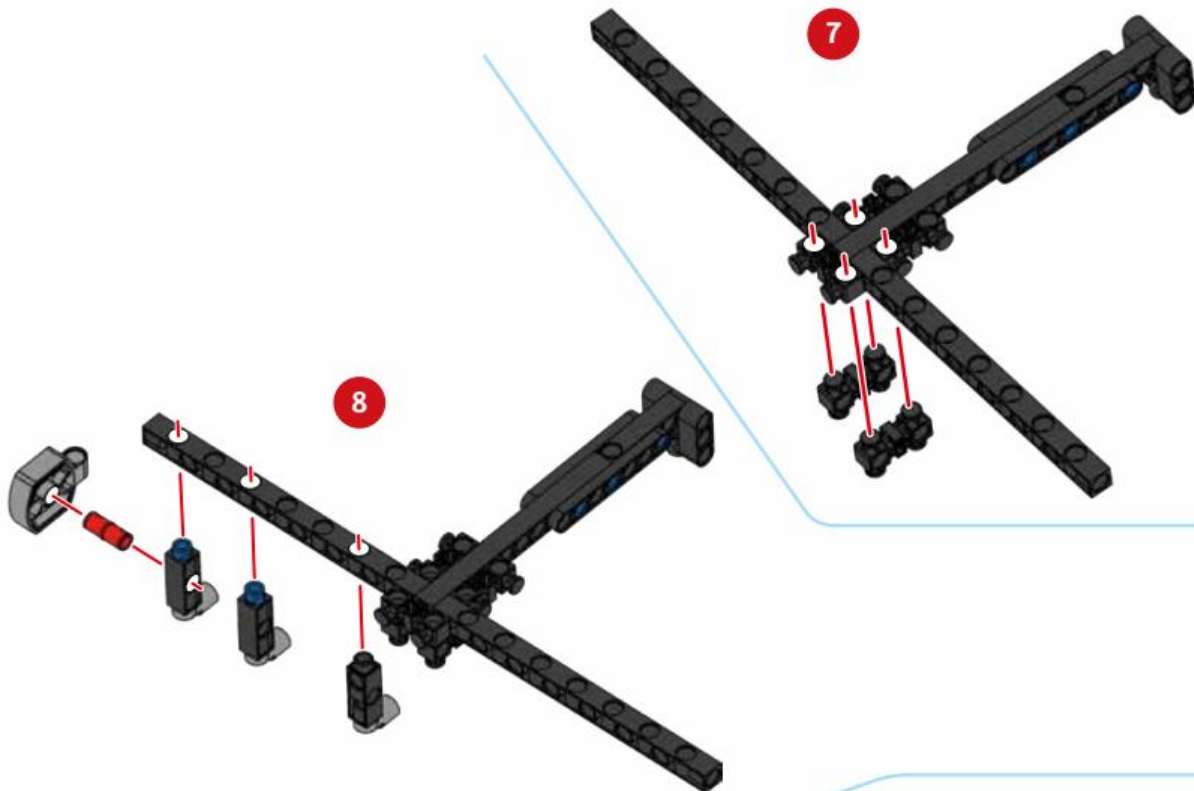

Model 3 CULTIVATOR

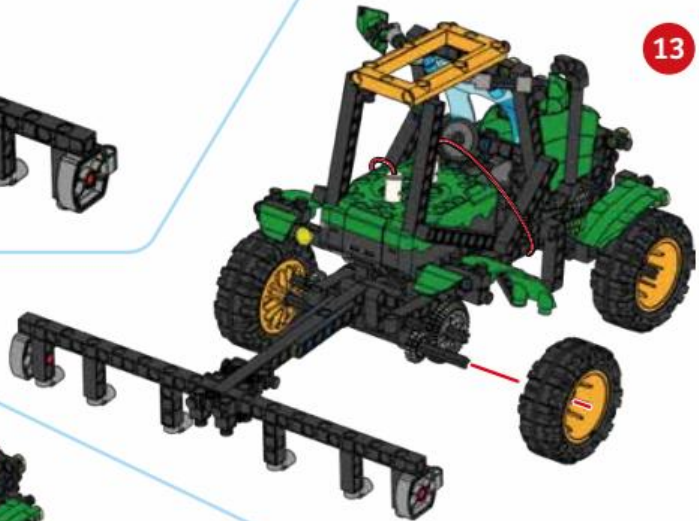
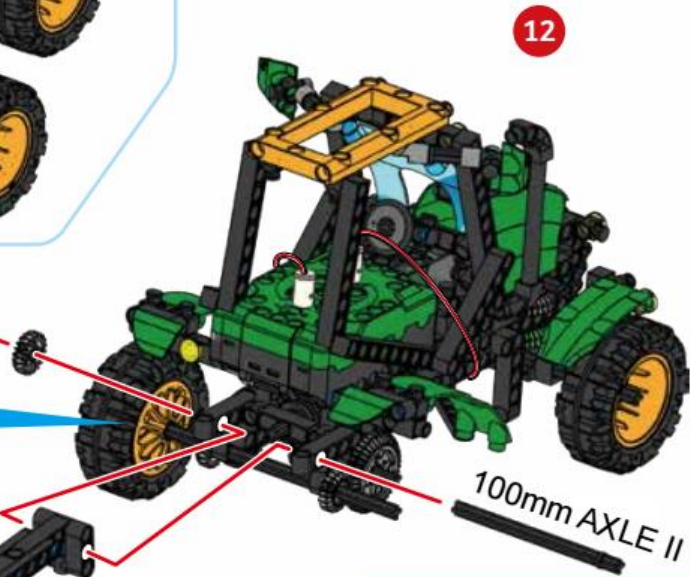
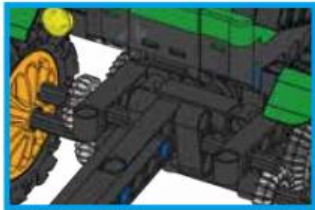

Done!

## CHECK IT OUT

Just like the disc harrow, cultivators are also used for secondary tillage after a field has been plowed. However, cultivators are designed to disturb the soil surface in specific patterns so that crop plants are spared and weeds are killed.

Cultivators are attached to tractors using what is called a three-point hitch. If the cultivator needs mechanical power from the tractor, it can also be attached to a power takeoff (PTO) shaft on the tractor.

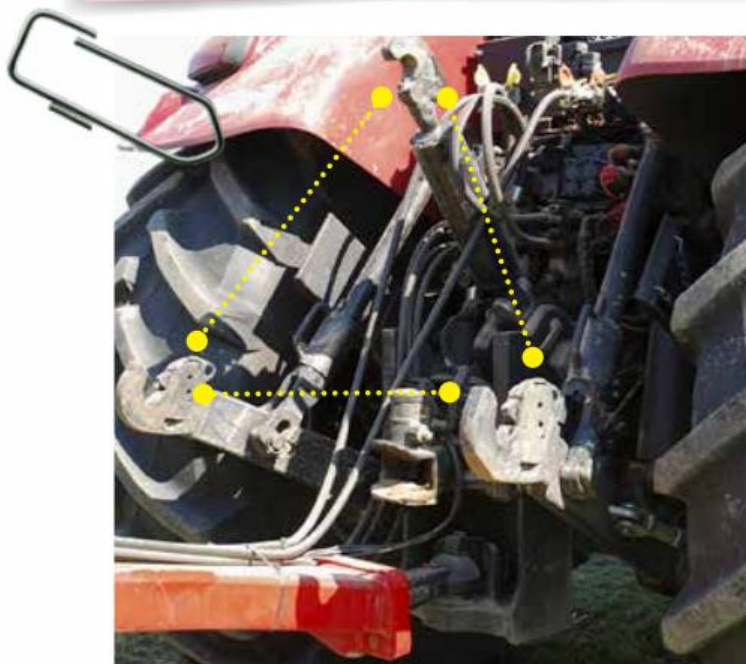

## Three-Point Hitch

The three-point hitch is used to attach implements to tractors. The three attachment points of the three-point hitch are positioned like the points of a triangle. The lower two attachment points are often connected to the hydraulic system of the tractor, allowing the attachment to be lifted up and down.

The three-point hitch is used because it is the simplest way to attach an implement to a tractor, in which the implement is held in a fixed position with respect to the tractor. An advantage of using a three-point hitch is that it transfers some or all of the weight of the attachment to the tractor.



## Power Takeoff (PTO)

A power takeoff is a drive shaft which is connected to the engine of the tractor. It can be used to transfer mechanical power to farm implements that are attached to the tractor.



## Model 4 SEEDER

### Parts Needed

● ● ● Easy

11 x1	12 x19	14 x5	18 x2	19 x3	22 x4	23 x2
28 x2	29 x1	30 x3	32 x1	33 x2		
36 x5	37 x1	47 x4	50 x1			

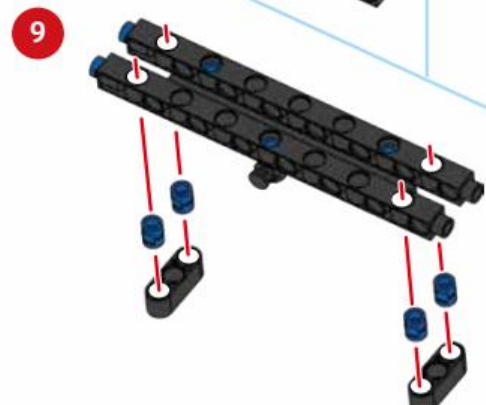
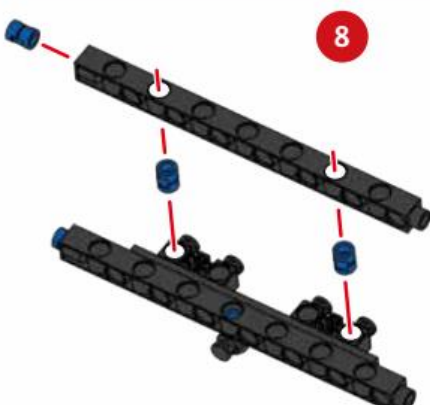
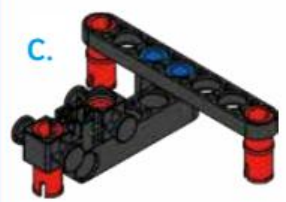
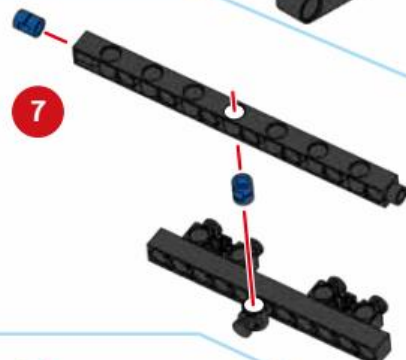
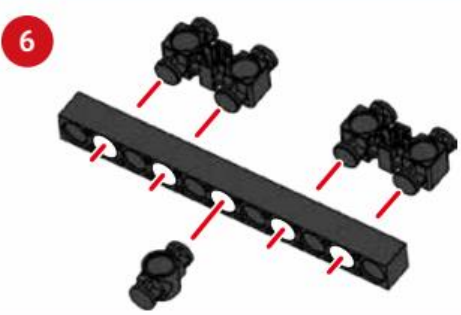
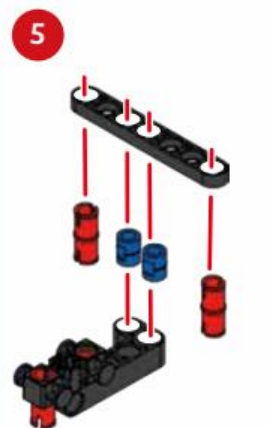
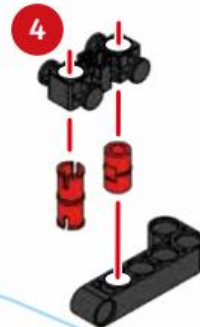
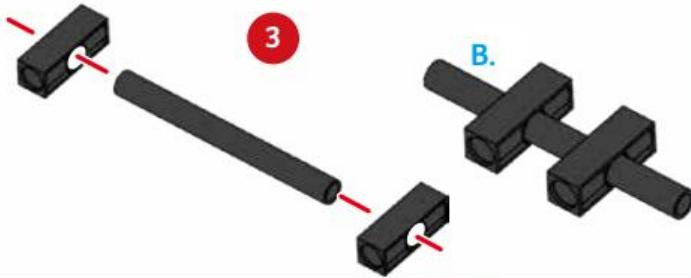
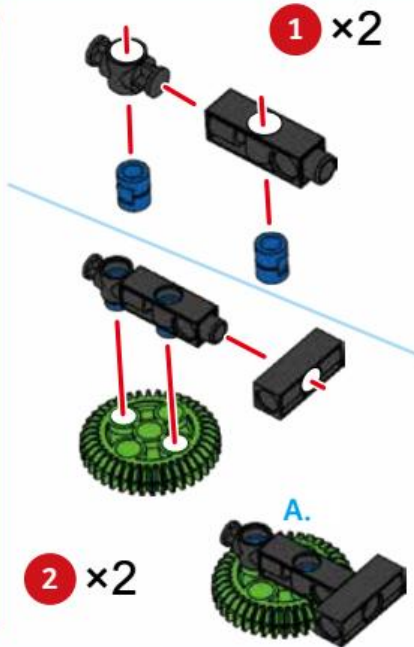

## SEEDER Model 4

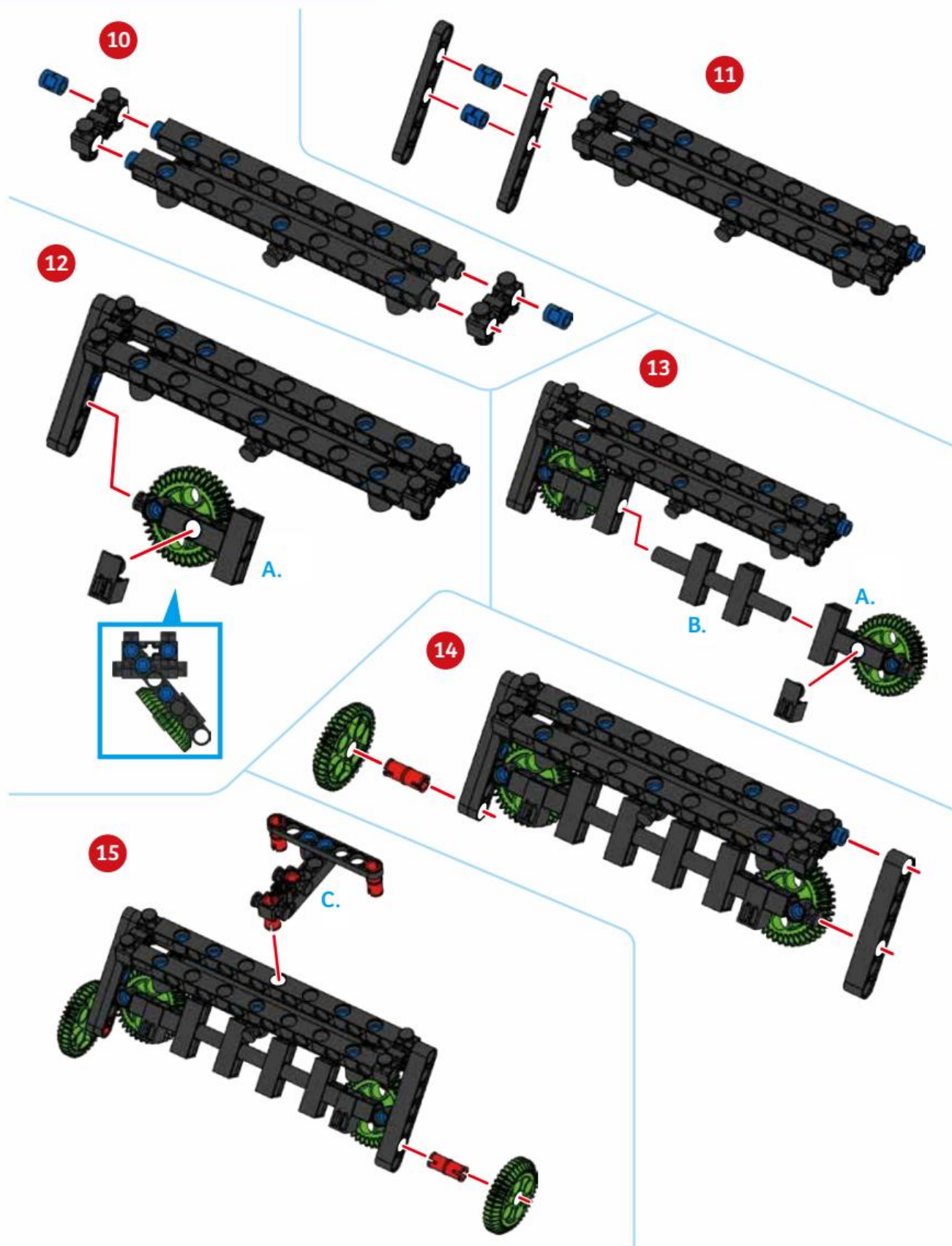



Model 4 SEEDER

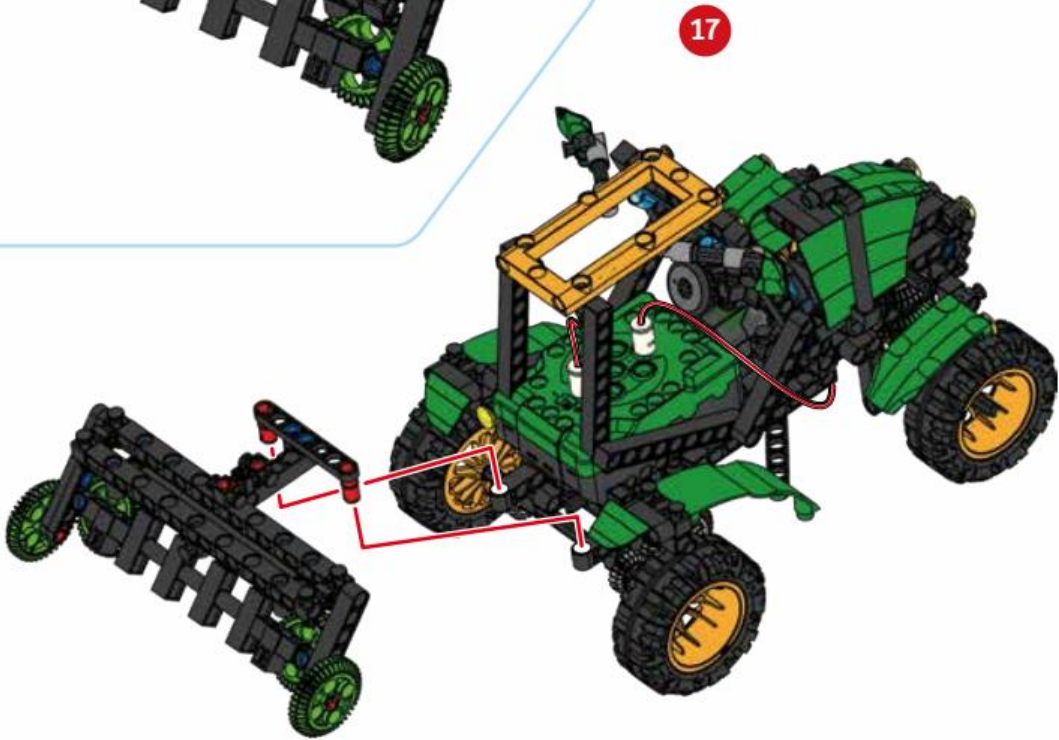
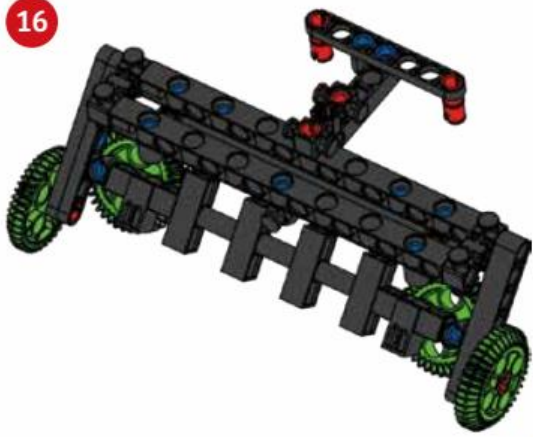

## CHECK IT OUT



A seeder sows seeds by metering out individual seeds, placing them in the soil, and then covering them up. A seeder ensures each that the seeds are planted at the correct depth and space from other and ensures that they are not eaten by birds. The use of seeders ensures that more of the seeds grow into plants, increasing crop yield.

## SOIL CHEMISTRY

To ensure proper plant growth, soil must also have the correct **soil chemistry**. The two fundamental factors in soil chemistry are **fertility** and **pH**.

pH is a measure how acidic or basic a solution is. An acid is a substance that gives off hydrogen ions ( $H^+$ ) when dissolved in water, while bases are substances that give off hydroxide ions ( $OH^-$ ) when dissolved in water. You encounter many acids and bases every day. Vinegar and lemon are examples of acids, while baking soda and ammonia are bases.

The pH scale goes from 0 to 14. Values below 7 are acidic and values above 7 are basic. Pure water has a pH of 7, which is considered neutral — neither acidic or basic.

The pH of soil is measured by mixing the soil in water and using an indicator. The indicator changes color if it is placed in an acid or base. pH is important for plant growth and health because it influences many different chemical processes. For example, pH affects the availability of different nutrients. The proper pH range for most plants is between 5.5 and 7.5.

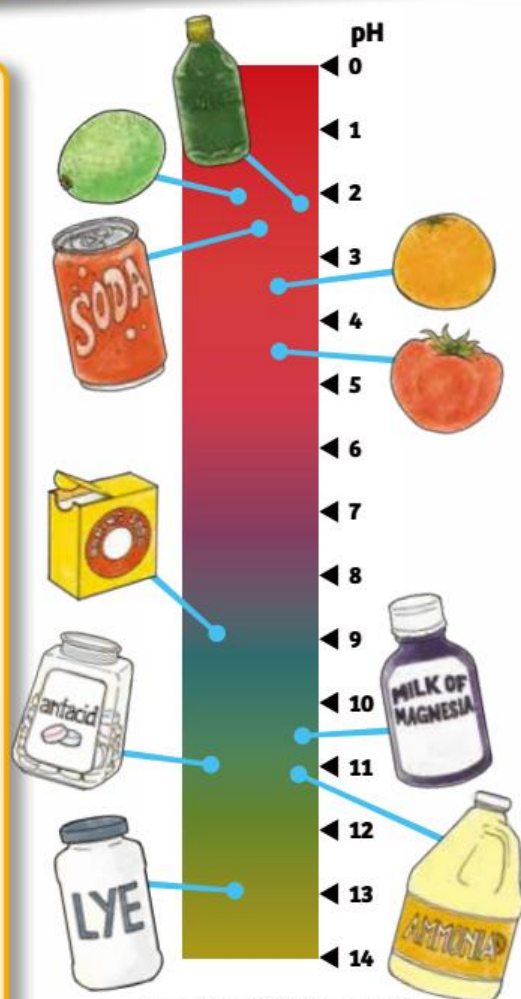

pH scale with the pH of some common items.

## Fertility

Fertility is a measure of the nutrients available in soil, primarily the amount of nitrogen, phosphorus, and potassium, or NPK for short. These three elements are vital to the growth of plants. You can often see the amount of NPK in fertilizers on their labels.



## Model 5 HAY RAKE

### Parts Needed

● ● ● Medium

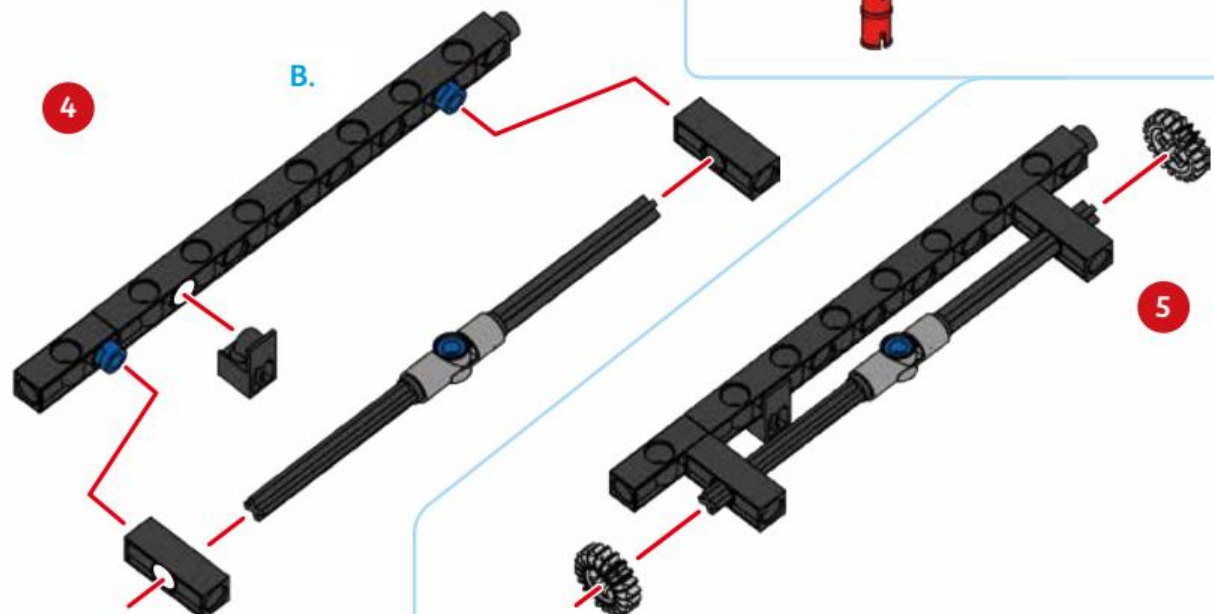
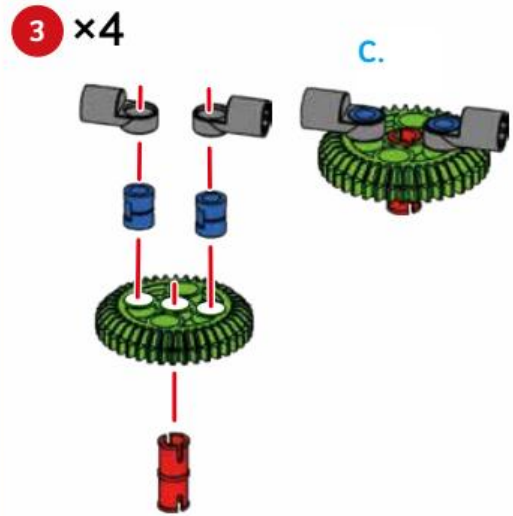
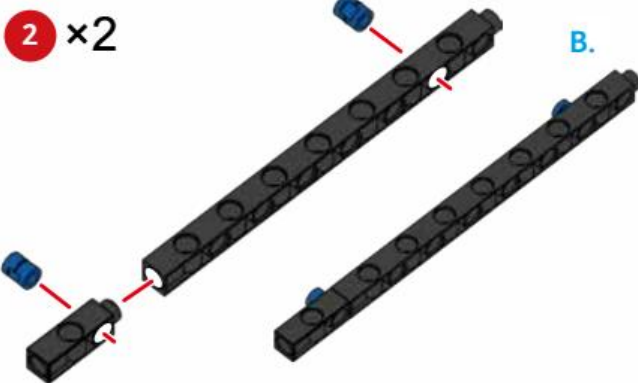
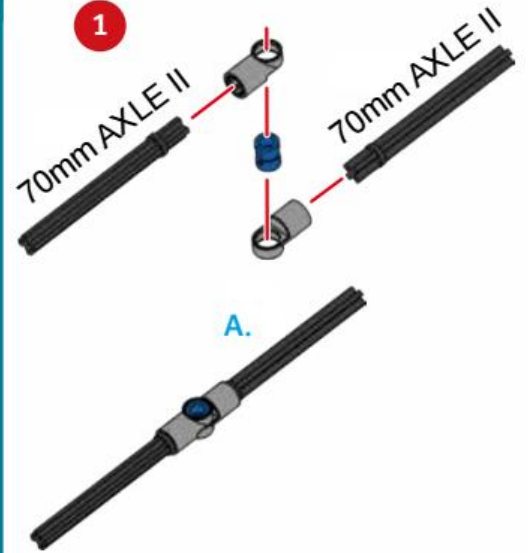
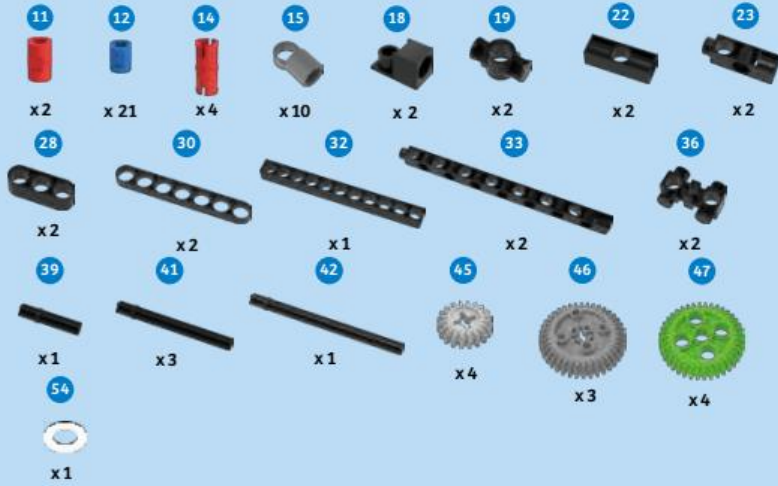

## HAY RAKE Model 5

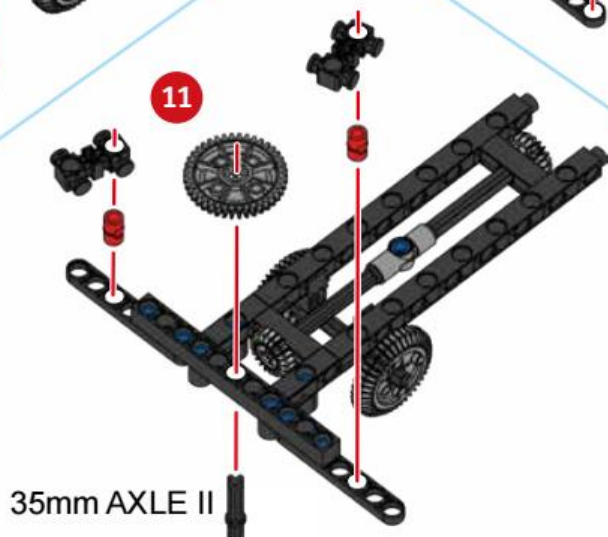
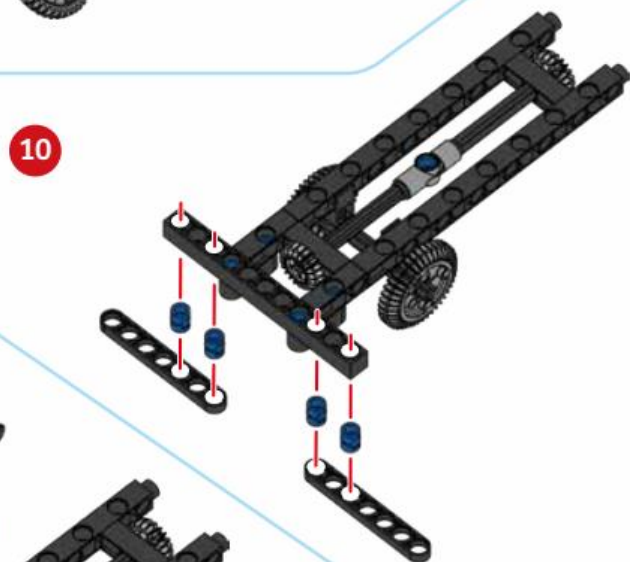
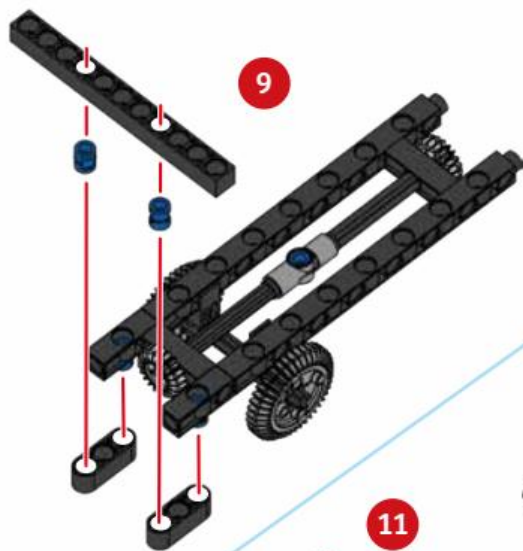
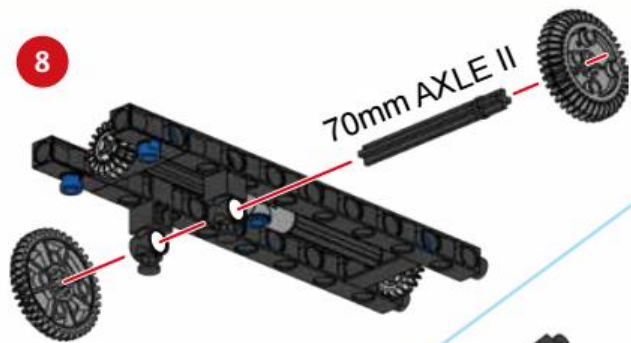
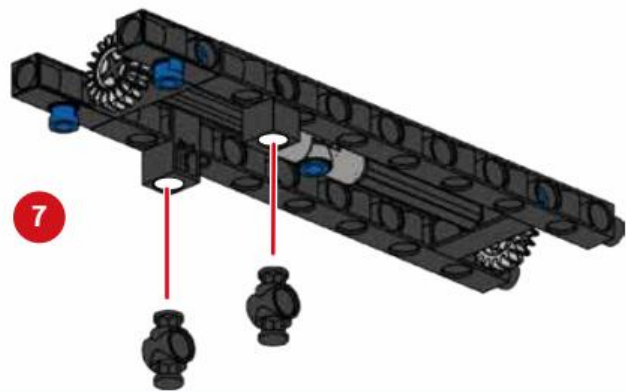
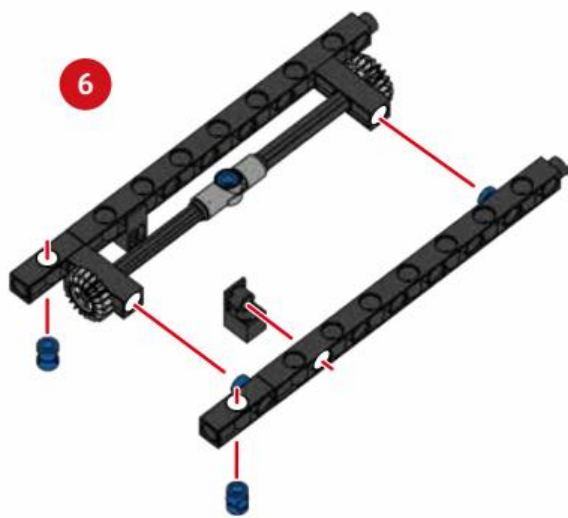

Model 5 HAY RAKE

12

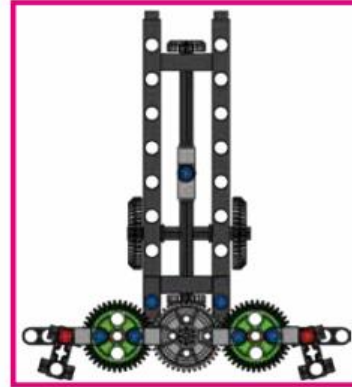
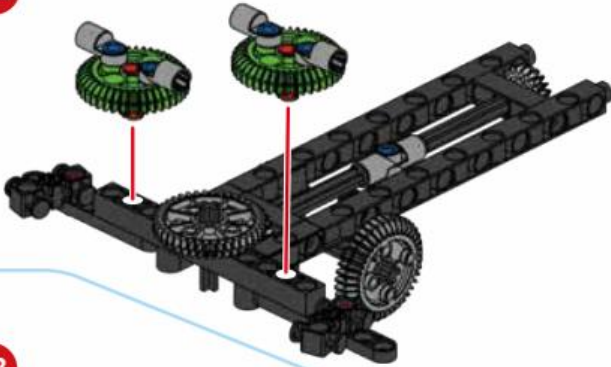

13

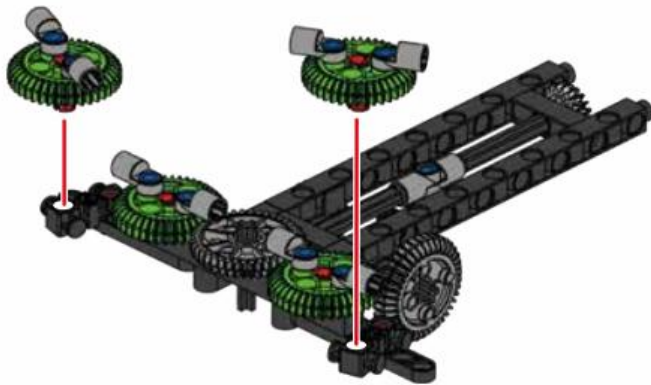

14

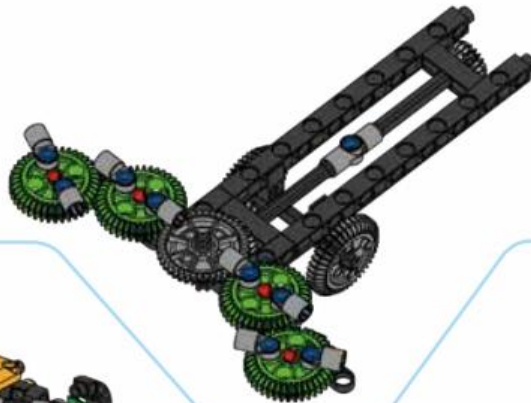

15



Remove one rear wheel

16



## HAY RAKE Model 5

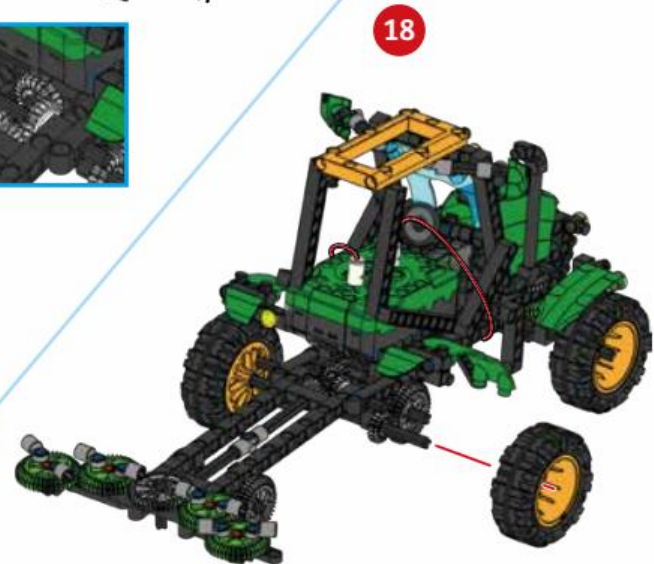
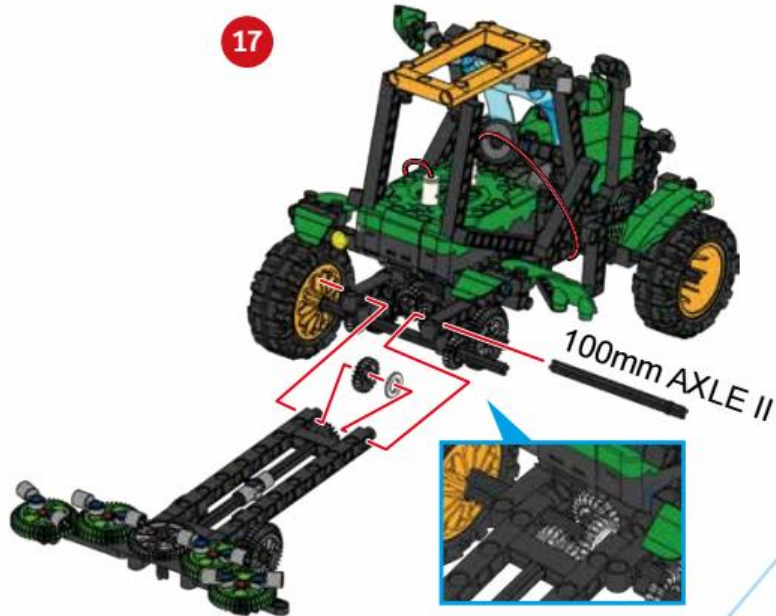

### EXPERIMENT 3

## Spinning gears

### HERE'S HOW

As the gears on the hay rake turn, look at the speed of the different gears. What do you observe about the speeds of the small gray gears and large green gears?

Done!





## CHECK IT OUT

## MAKING HAY

Hay is made from herbaceous plants, such as grass, and is used to feed animals. Making hay is a multi-step process. First the hay is cut and allowed to dry in the sun. Then it is collected into long, narrow rows known as **windrows** by a hay rake. A hay rake works just like a garden rake that is used to collect leaves. However, the forks of the rake are driven by gears. Finally, the hay is bundled into hay bales and stored until it is used.



## SIMPLE MACHINES: GEARS

Gears are used in many different devices to transfer power. A gear is a rotating wheel that is connected to an axle and has teeth or cogs that are intermeshed with another set of teeth. Gears transfer power by changing the direction, speed, or torque of another gear.



## NATURE'S GEARS

### Did you know ...

... that gears have been found in insects? In 2013, scientists from the University of Cambridge found gears (right) in the rear legs of the juvenile form of *Issus celoptratus*. The gears make it so that the insect's legs are synchronized when it jumps. The gear mechanism also gives the insect more power when it jumps.



## COMBINE HARVESTER Model 6

### Parts Needed



Hard

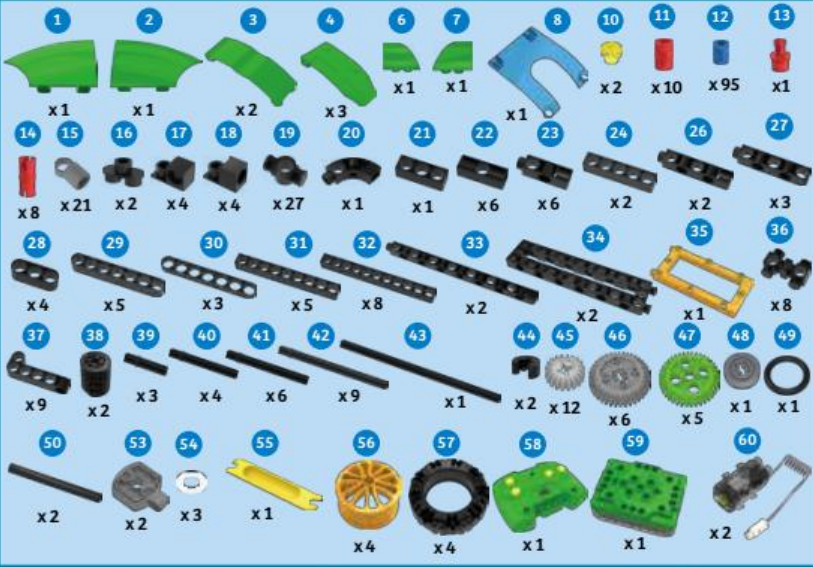

1 x4



2



3

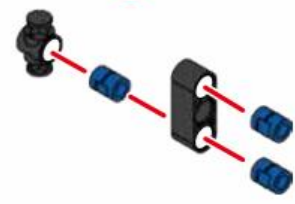

4

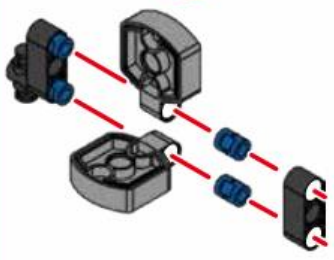

5

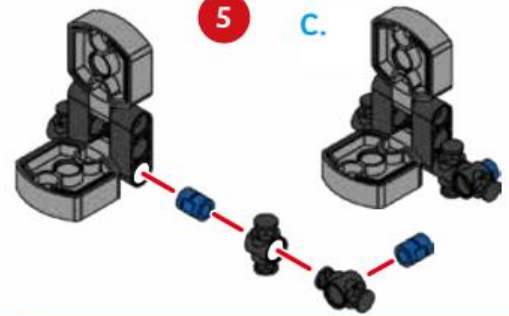

6

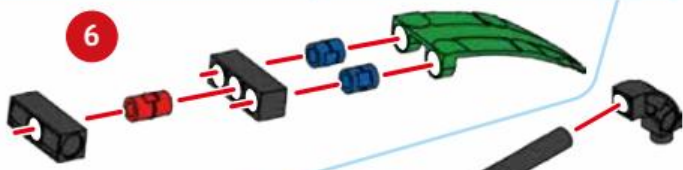

7

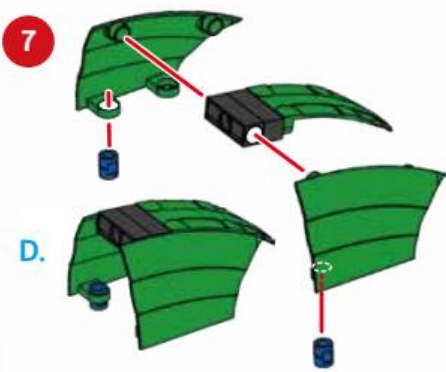

8

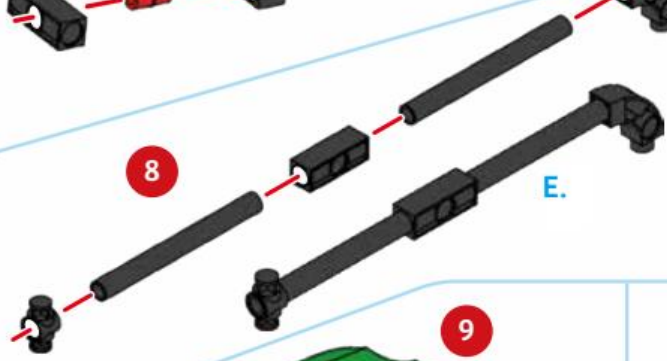

9

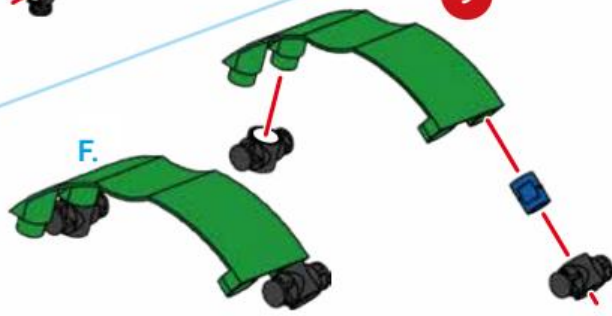

10

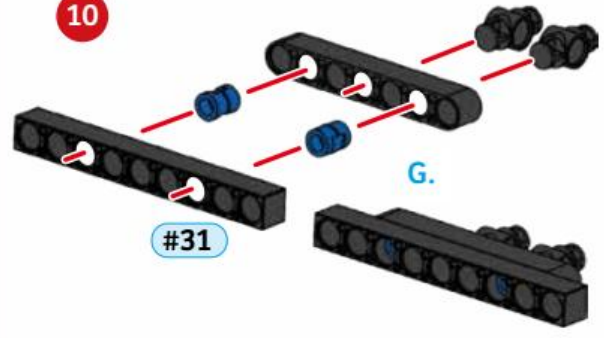

## Model 6 COMBINE HARVESTER

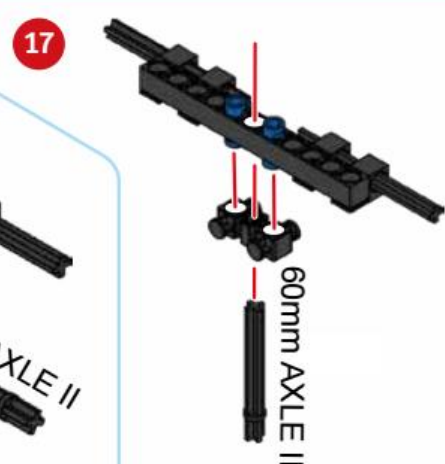
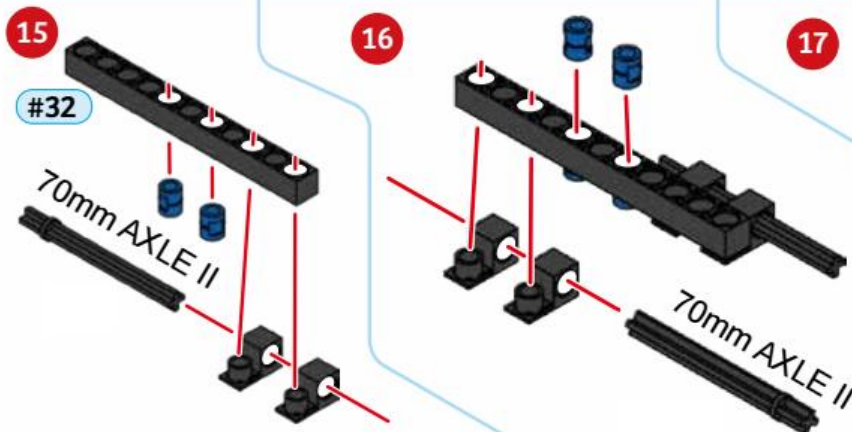
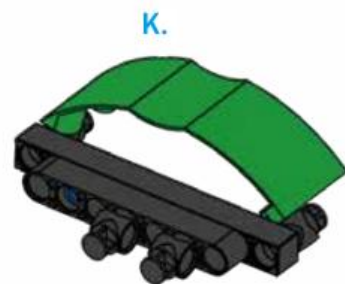
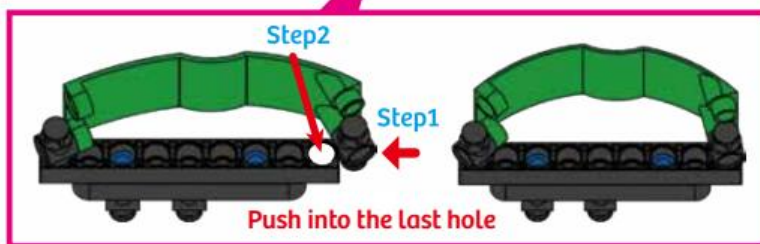
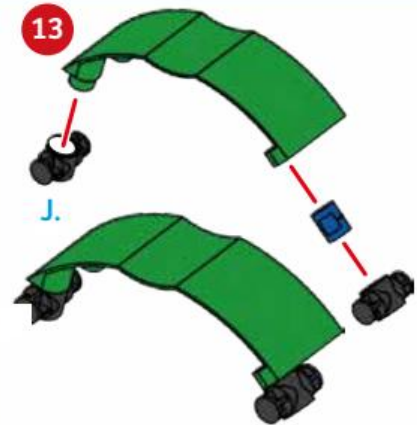
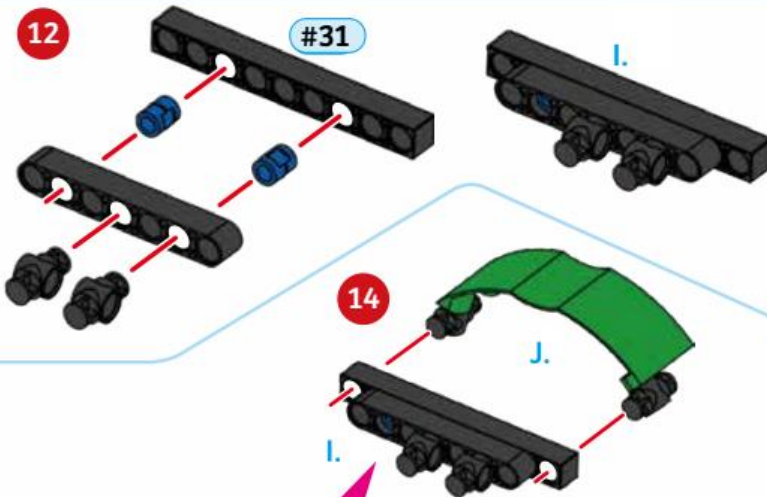
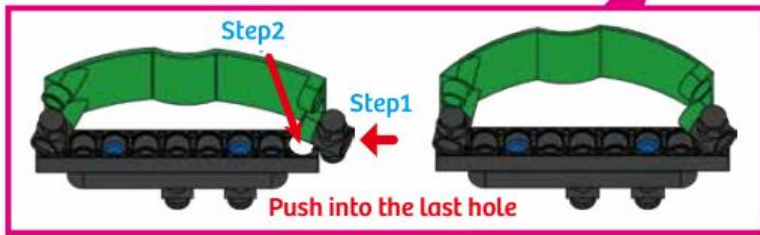
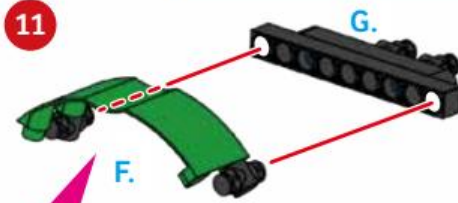

## COMBINE HARVESTER Model 6

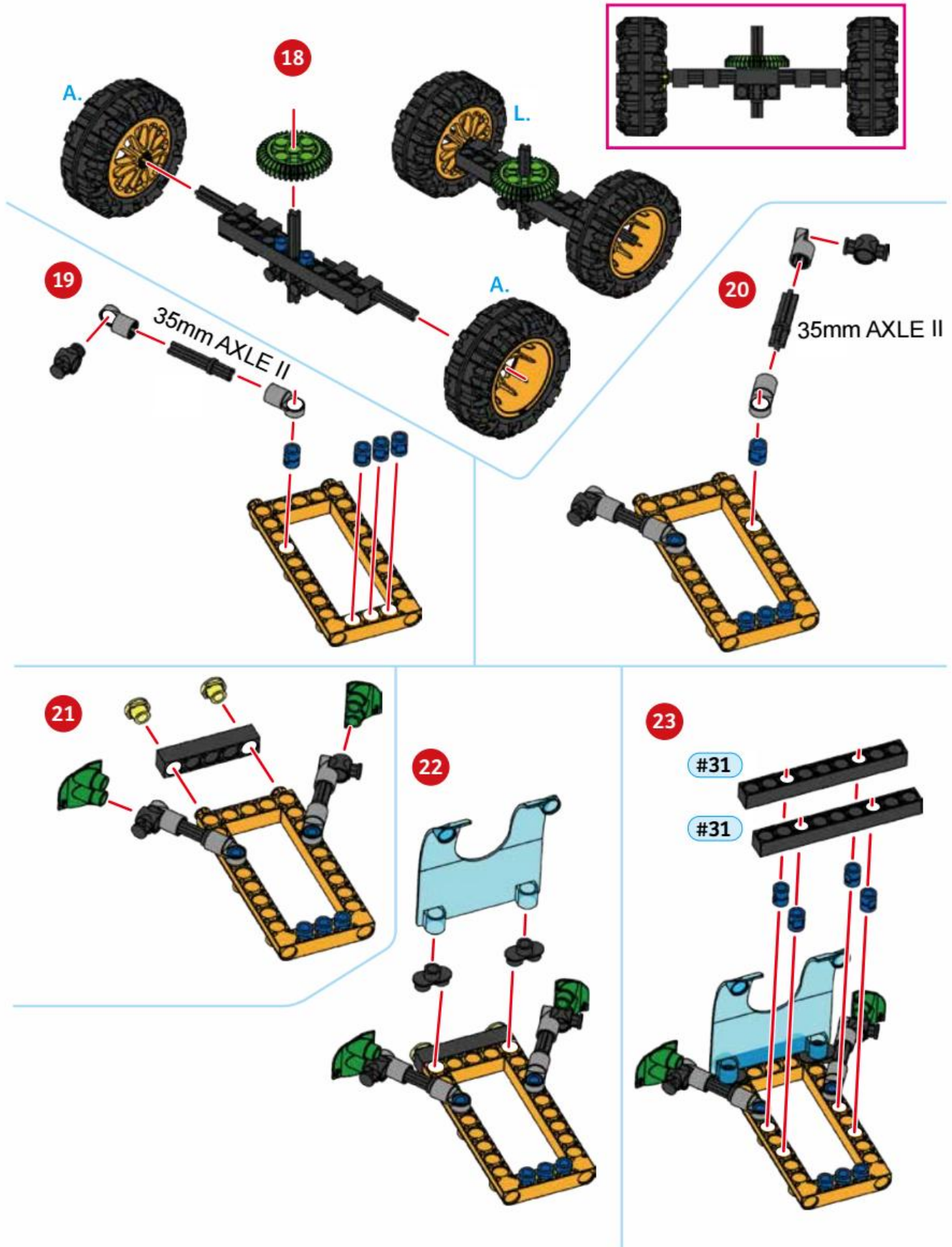

Model 6 COMBINE HARVESTER

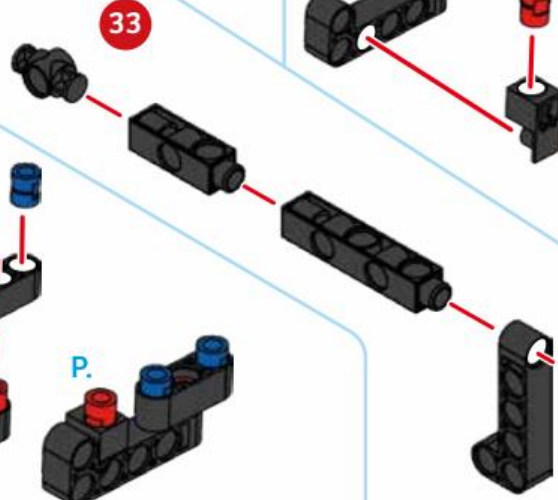
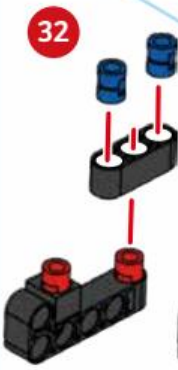
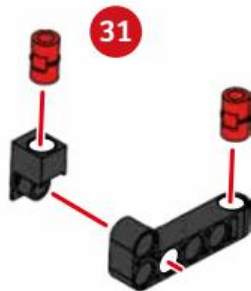
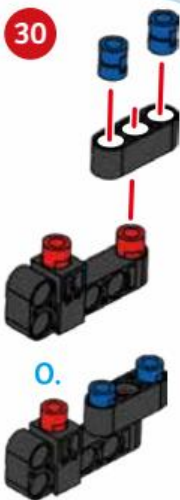
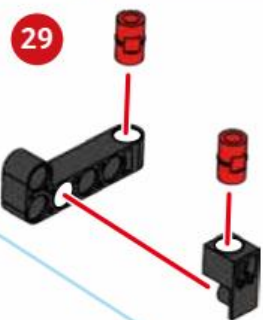
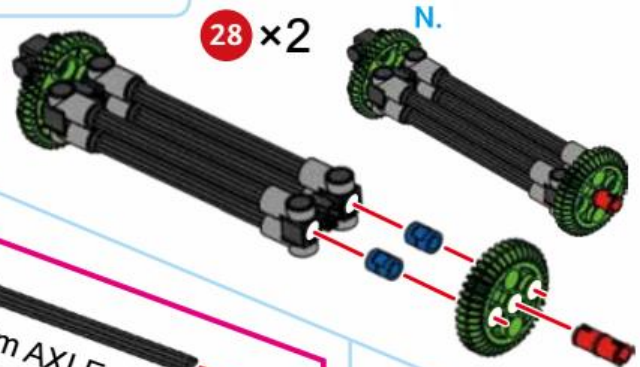
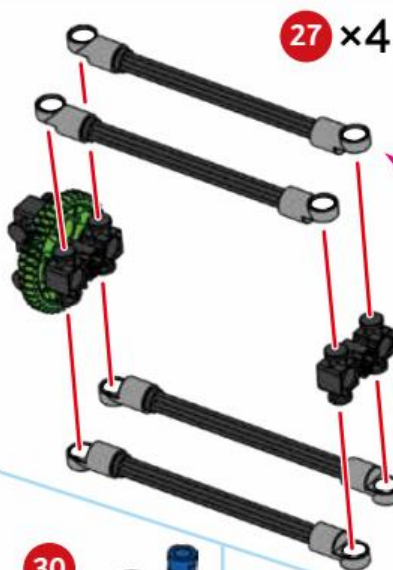
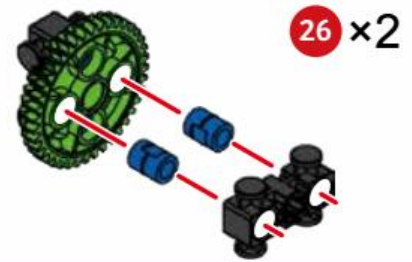
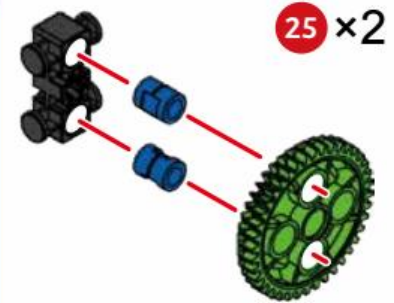
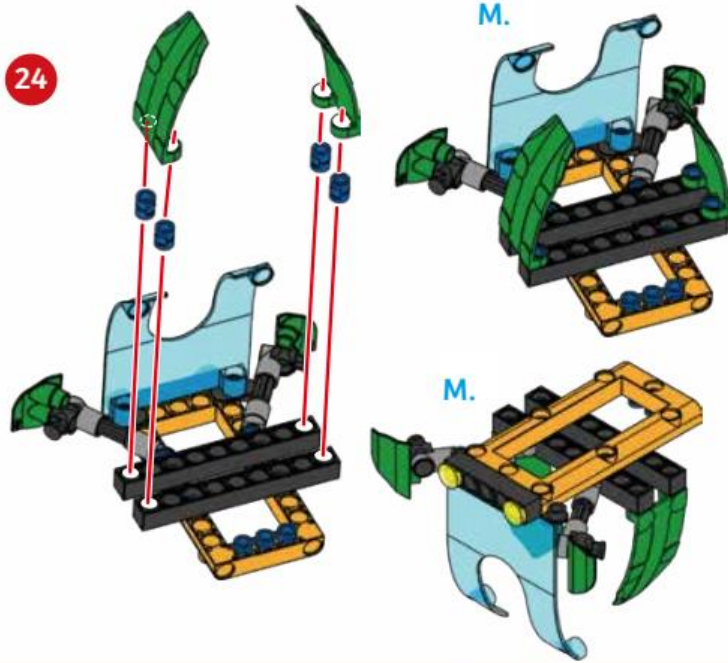

## COMBINE HARVESTER Model 6

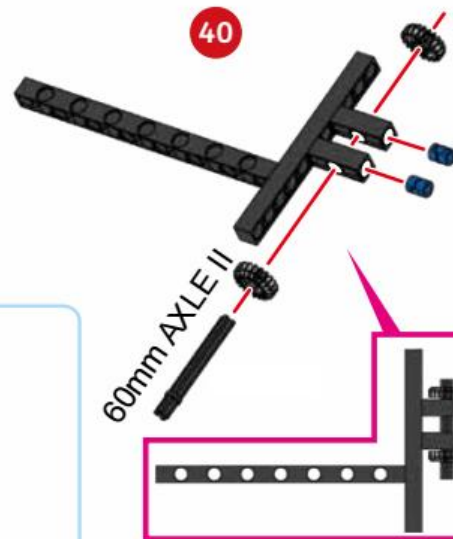
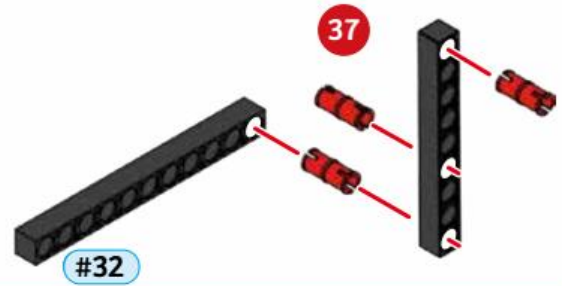
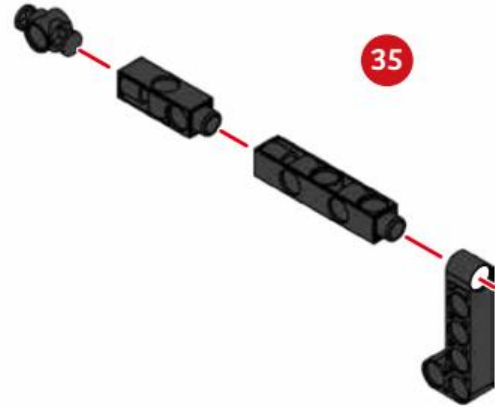
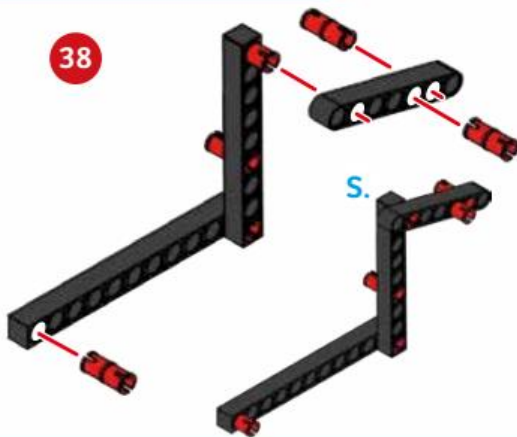
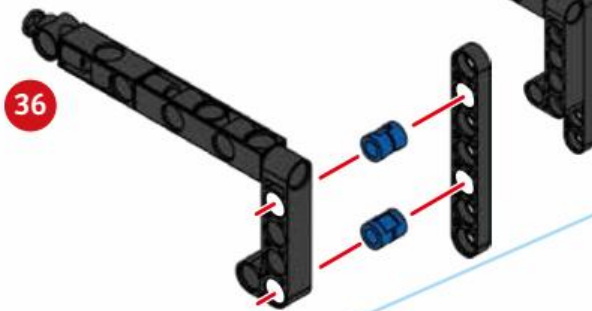
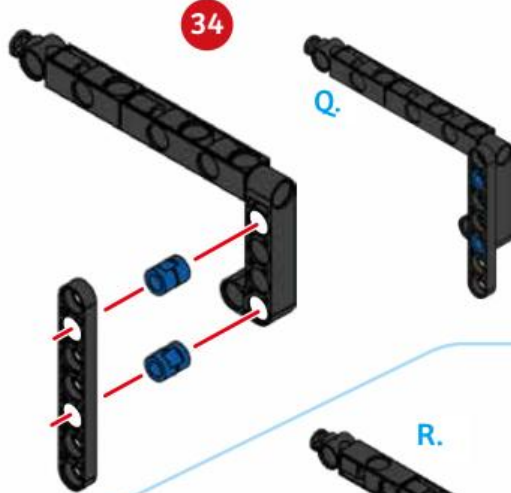

**TIP!**  
Note the gear direction.

Model 6 COMBINE HARVESTER

42

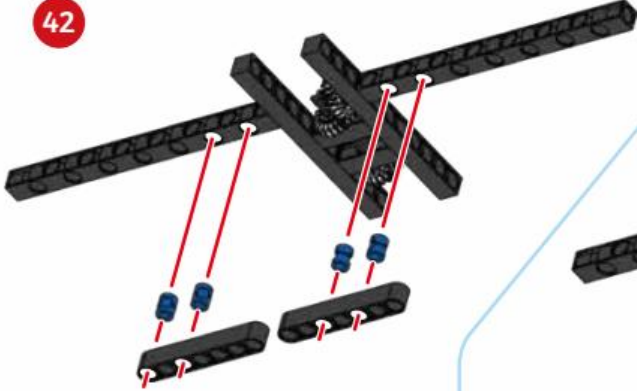

43

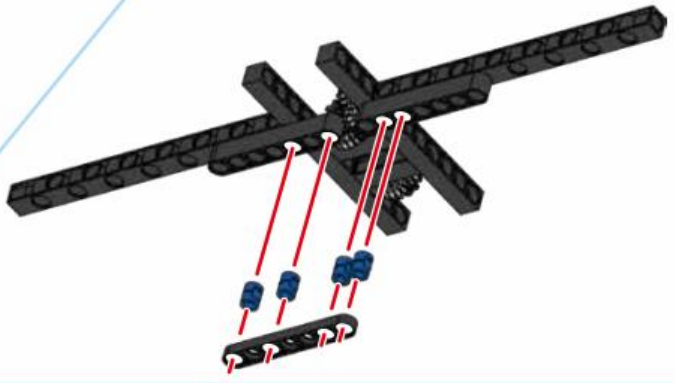

44



45

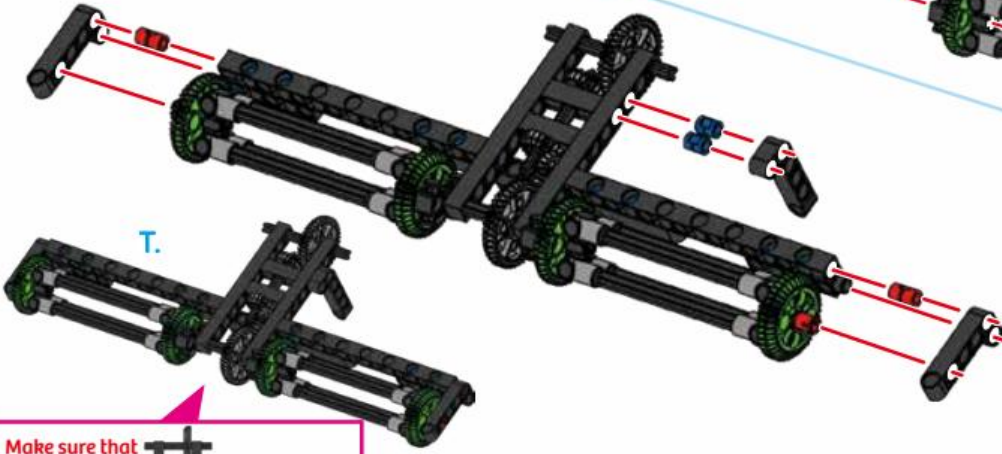
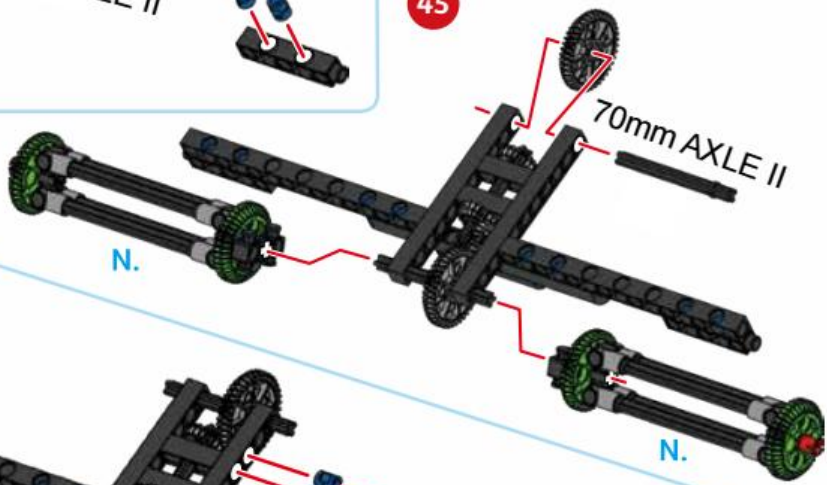

Make sure that all gears rotate smoothly

## COMBINE HARVESTER Model 6

47

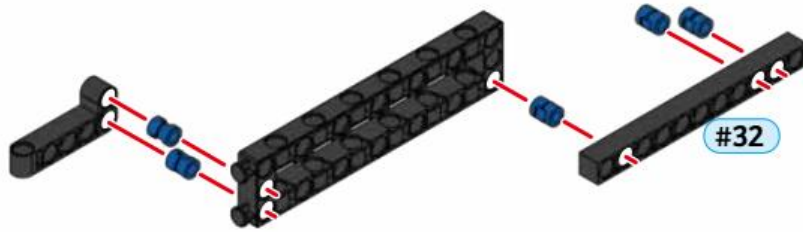

48

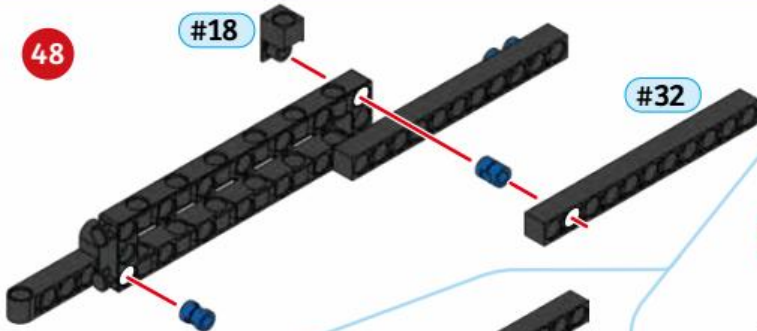

50

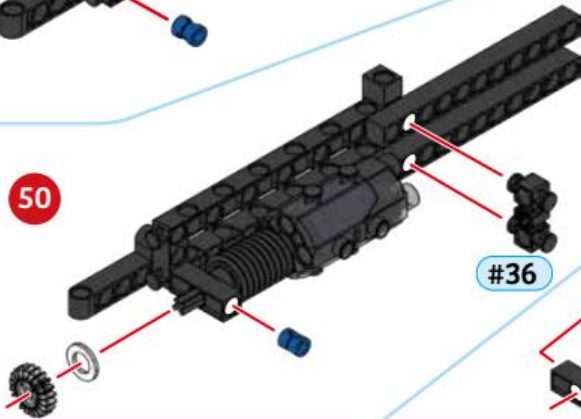

49

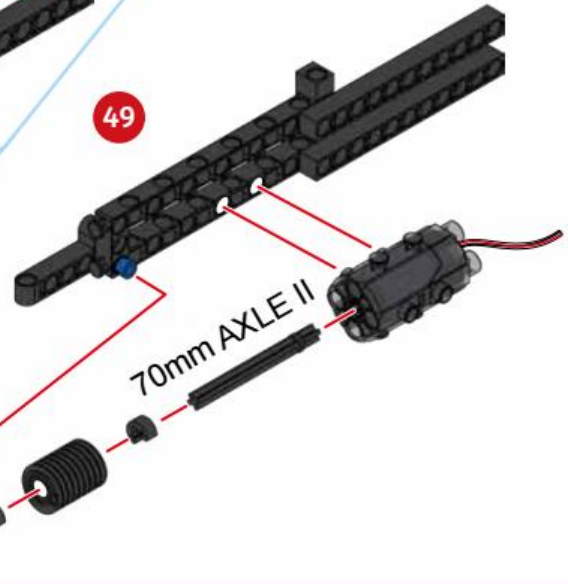

51

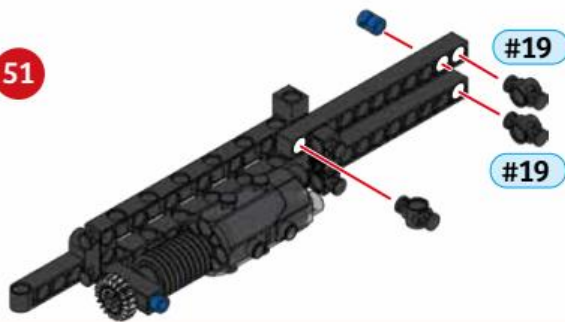

53



52

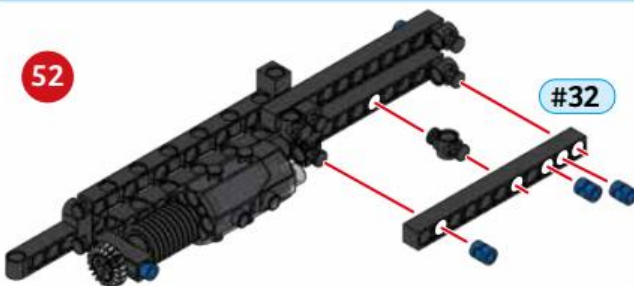



Model 6 COMBINE HARVESTER

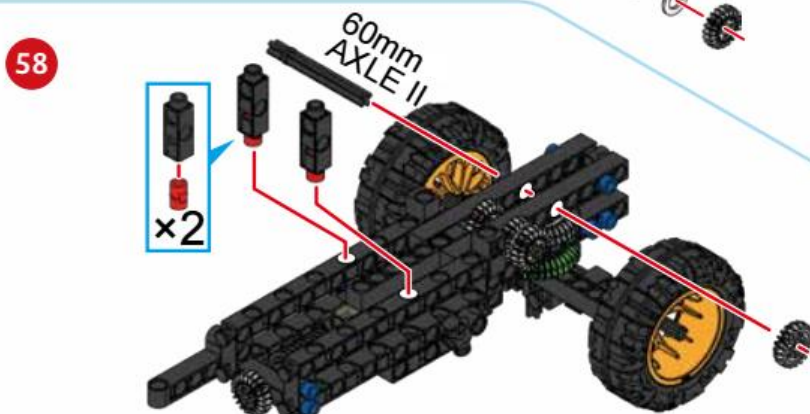
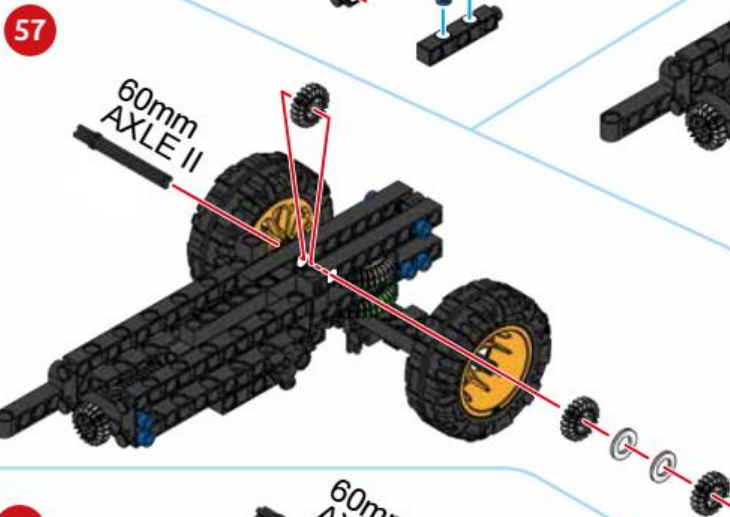
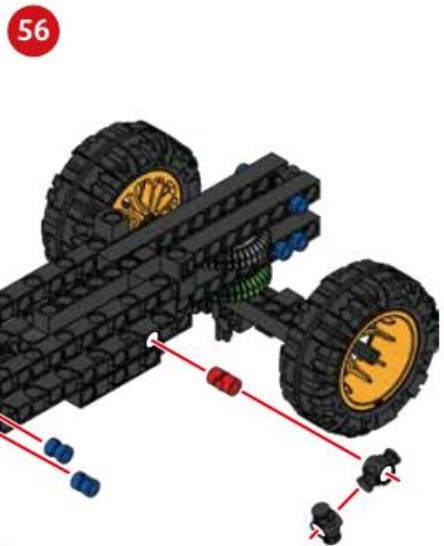
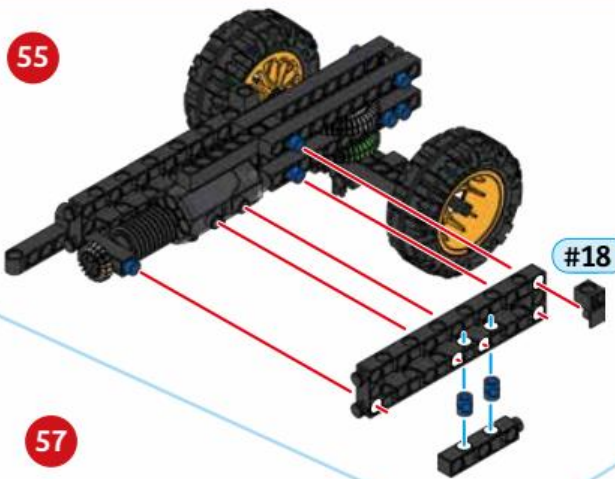
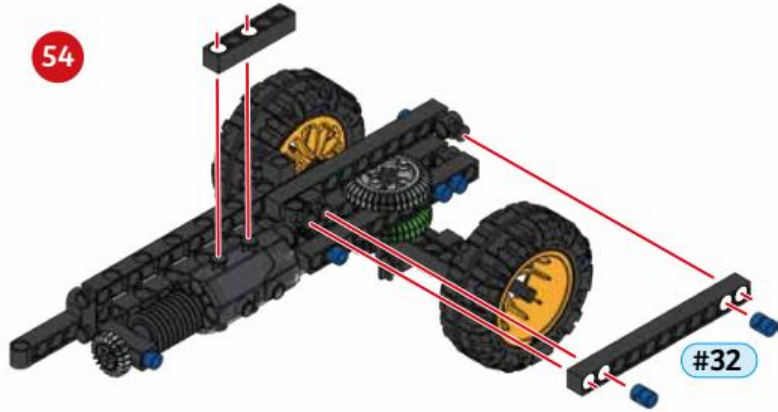

## COMBINE HARVESTER Model 6

59

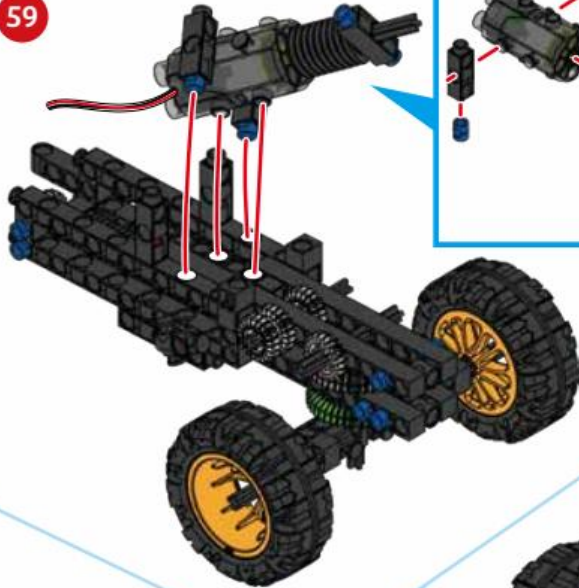

60

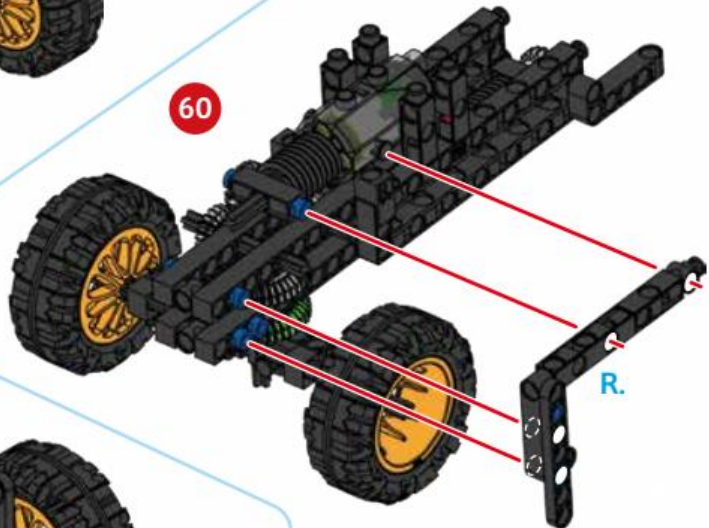

61

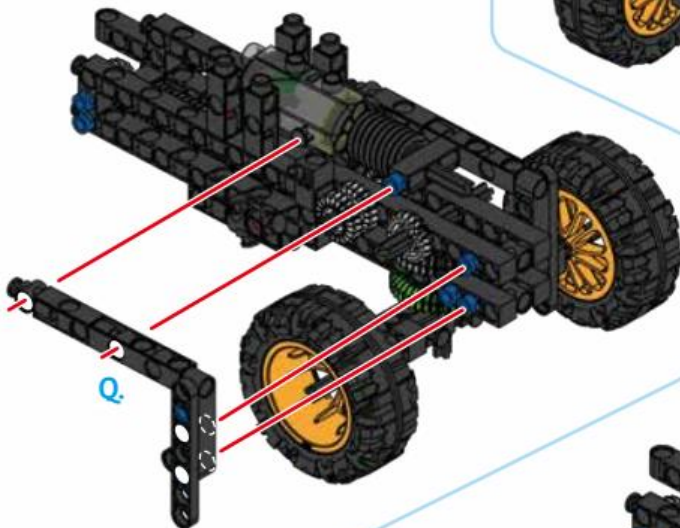

62

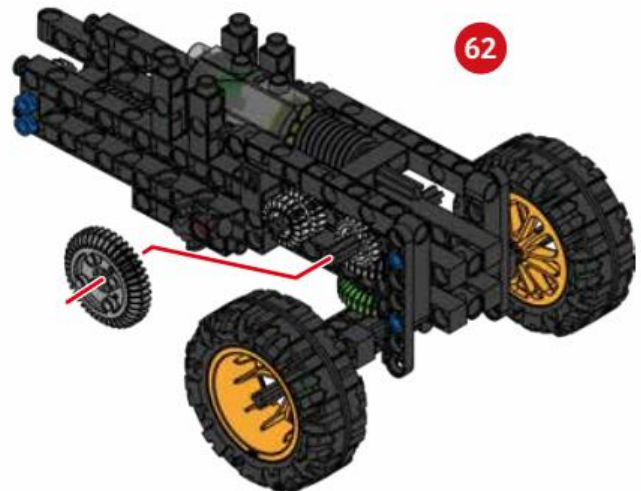

U.

Model 6 COMBINE HARVESTER

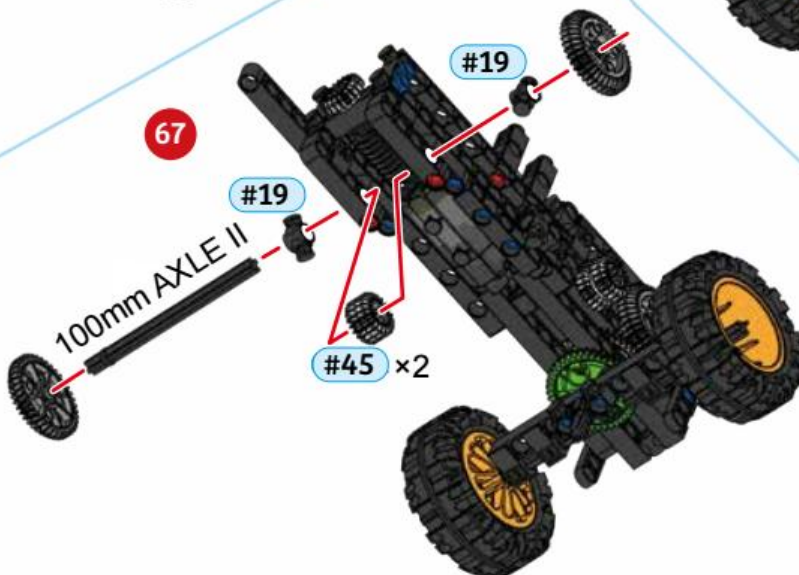
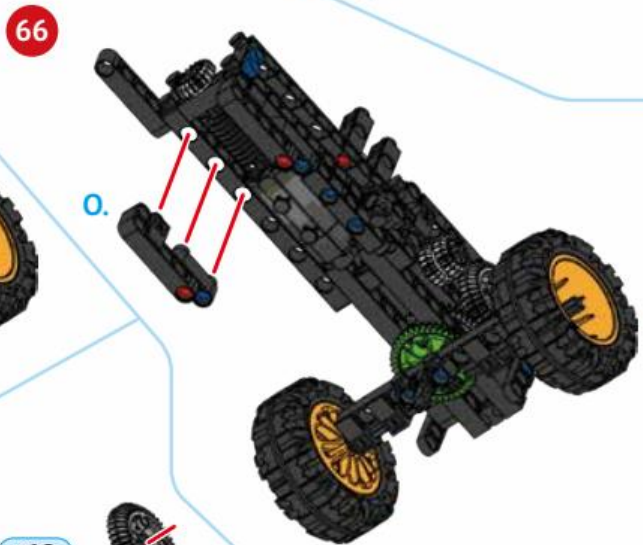
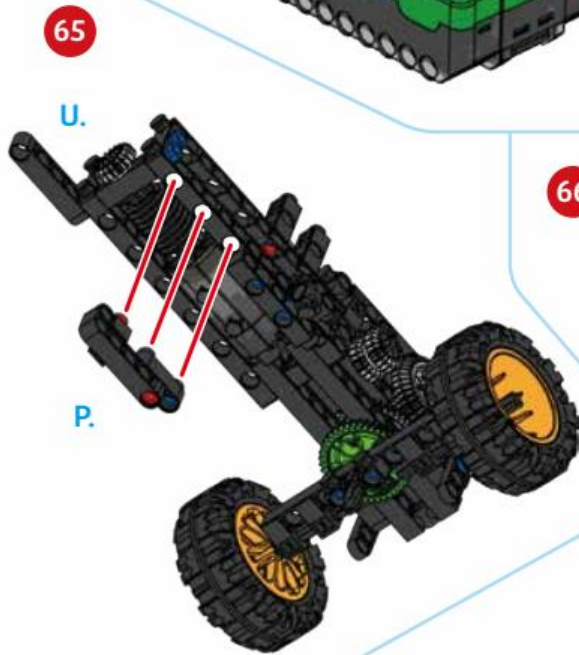
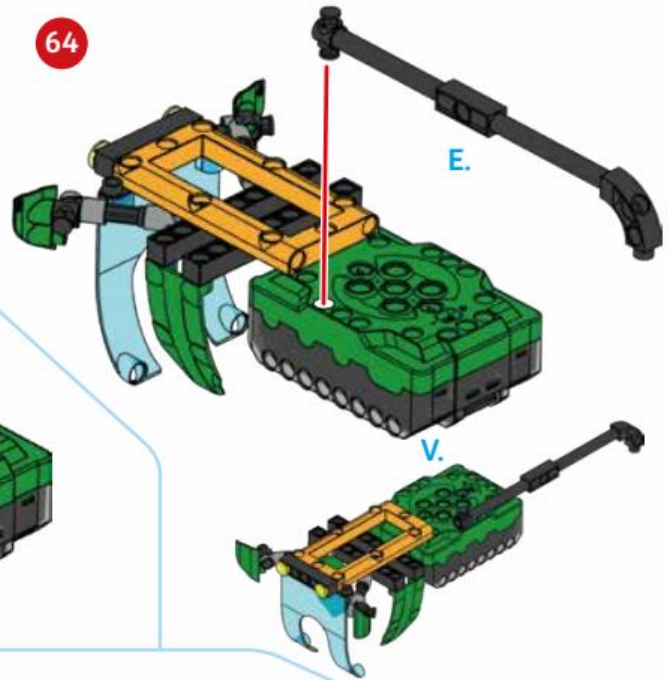
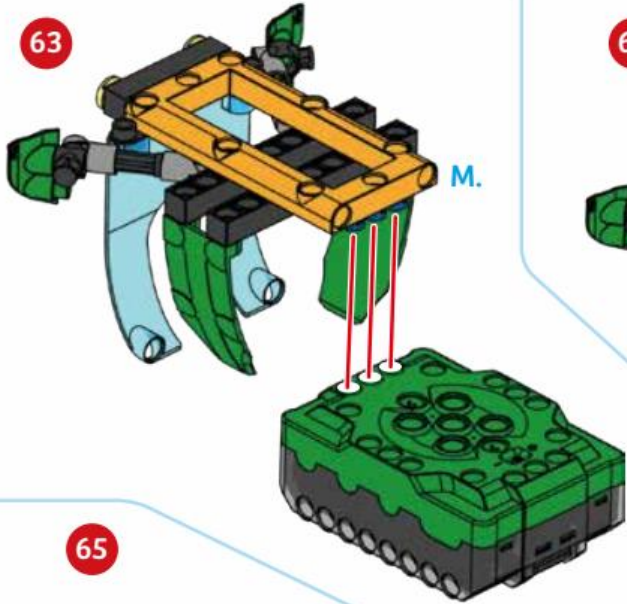

## COMBINE HARVESTER Model 6

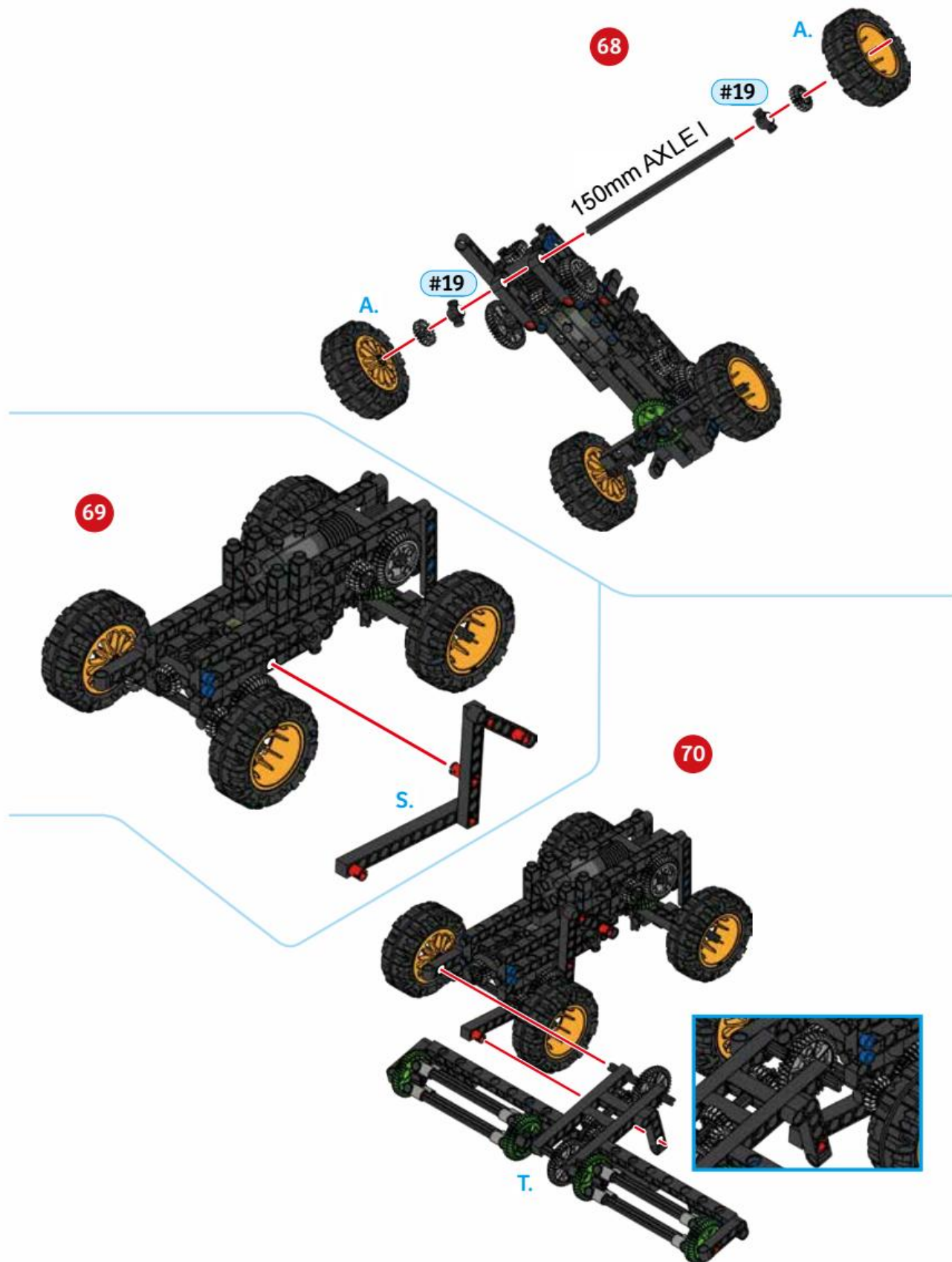

Model 6 COMBINE HARVESTER

71

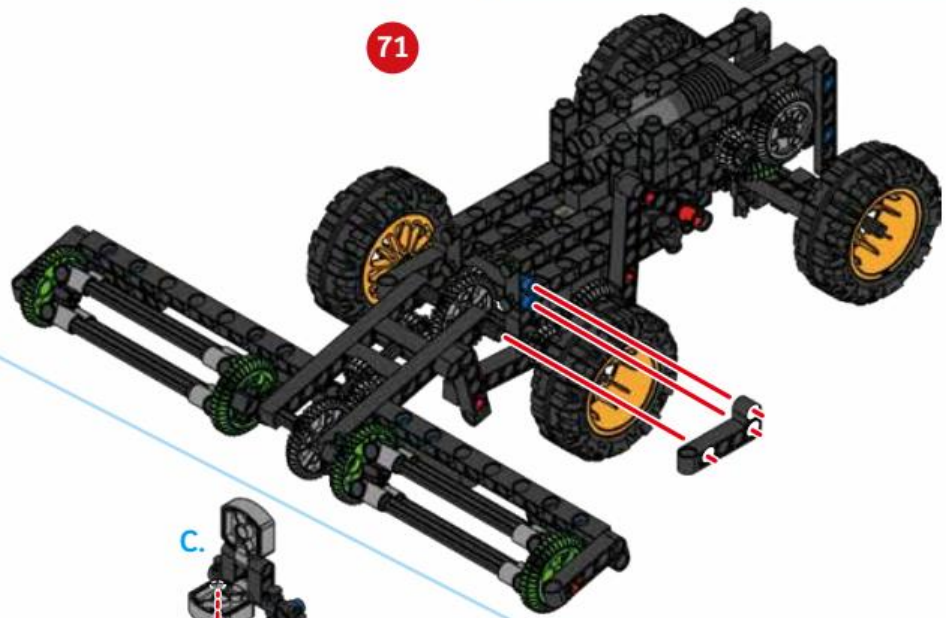

72

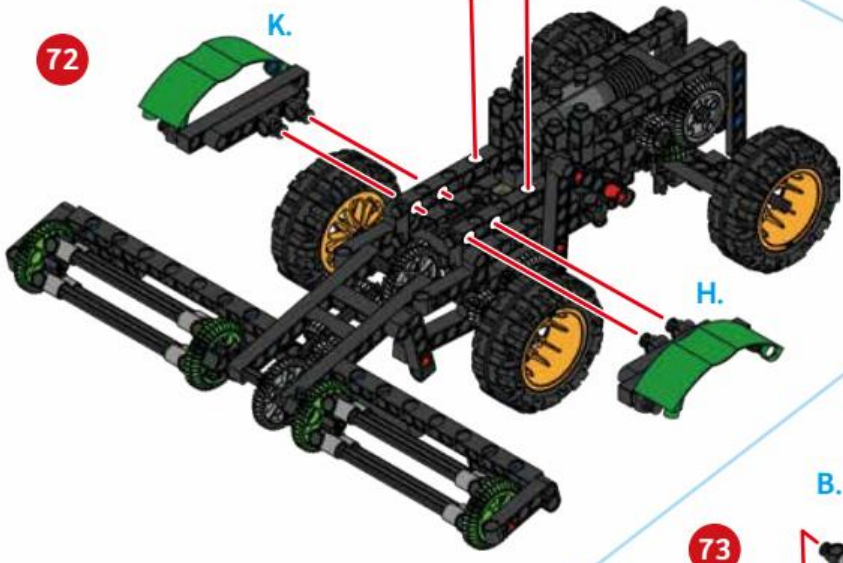

73

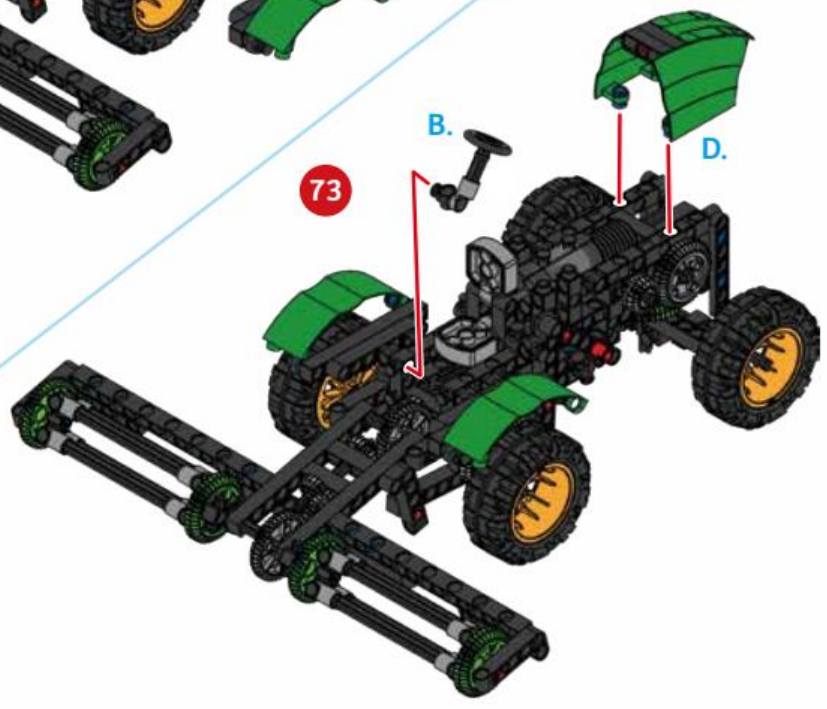

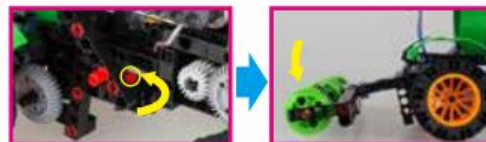
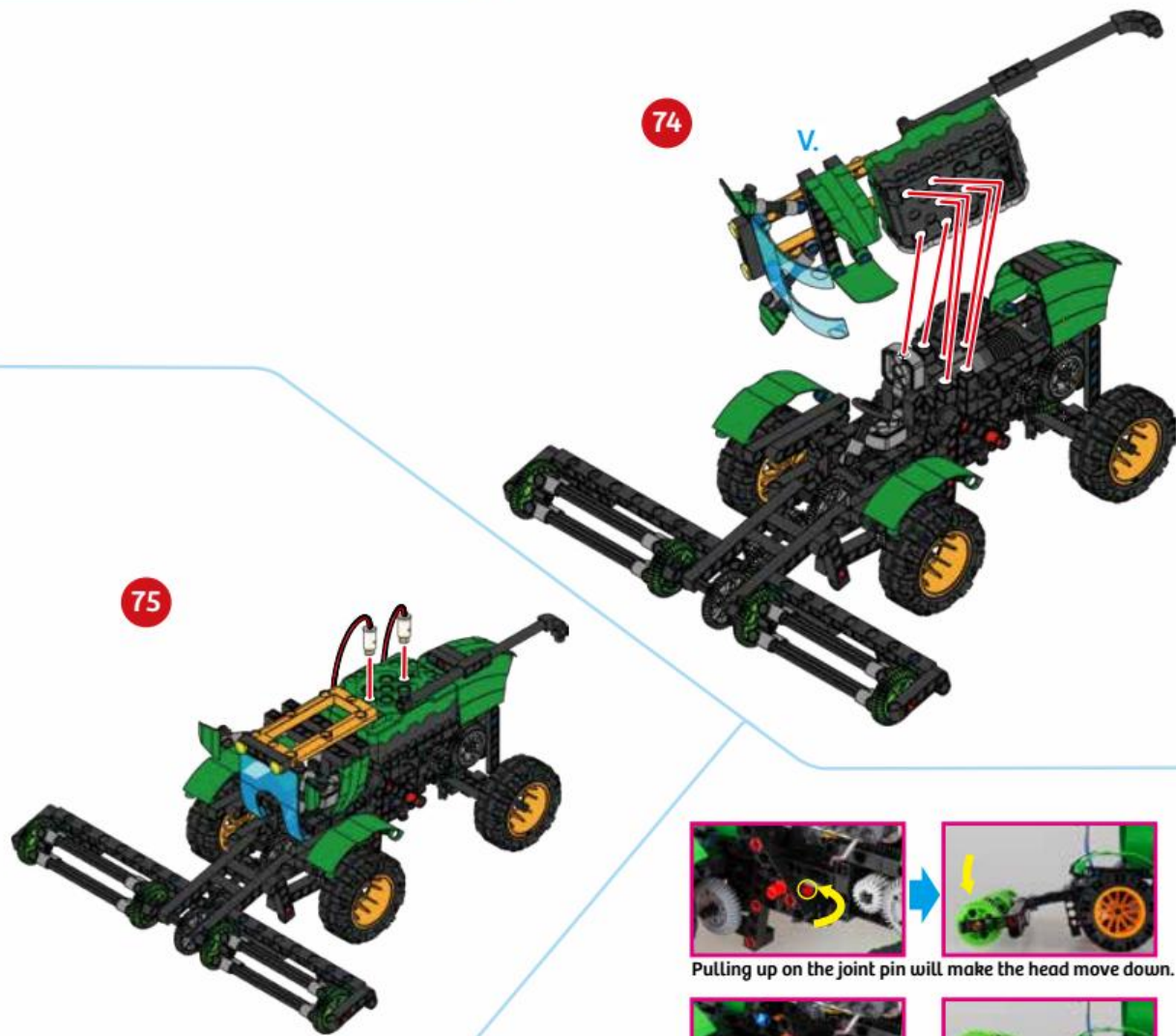

Pulling up on the joint pin will make the head move down.

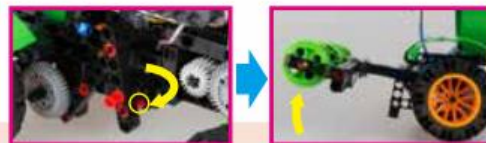

Pulling down on the joint pin will make the head move up.

### EXPERIMENT 4

## Reaping grass

### HERE'S HOW

Drive the combine harvester through a small patch of dry grass with the front tool of the combine harvester in the down position. What do you observe happens to the grass at the front of the combine harvester as it goes over it?

### 76 Done!

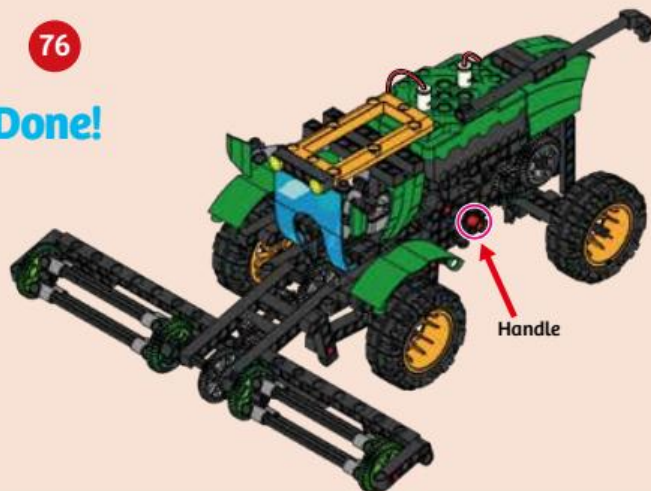



Model 6 COMBINE HARVESTER

1

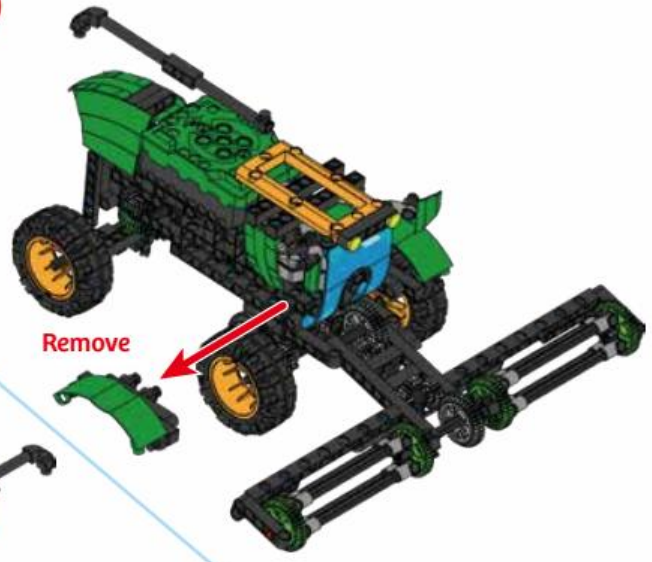

2

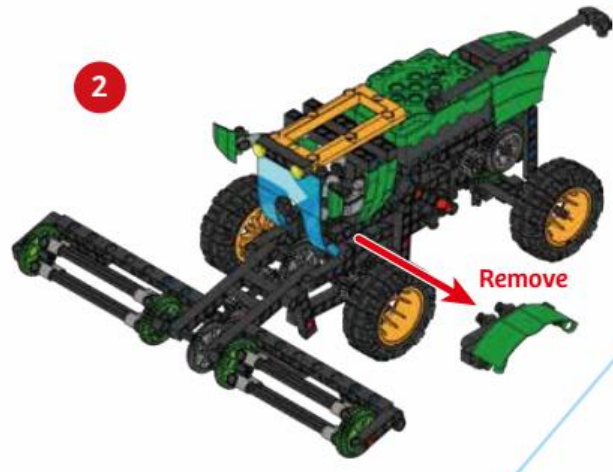

3

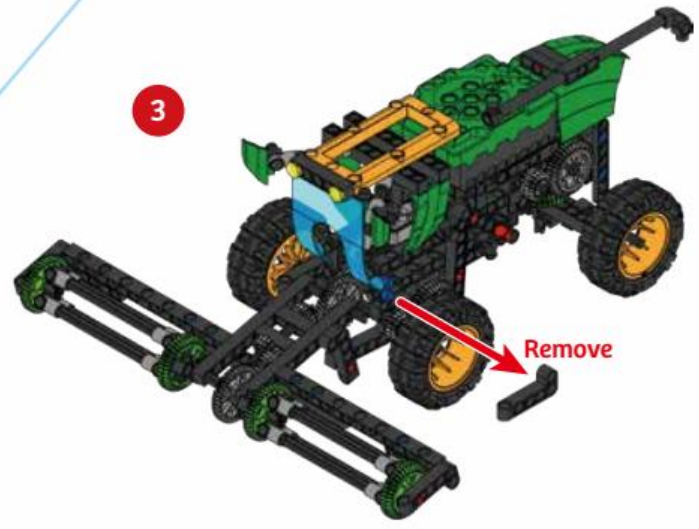

4

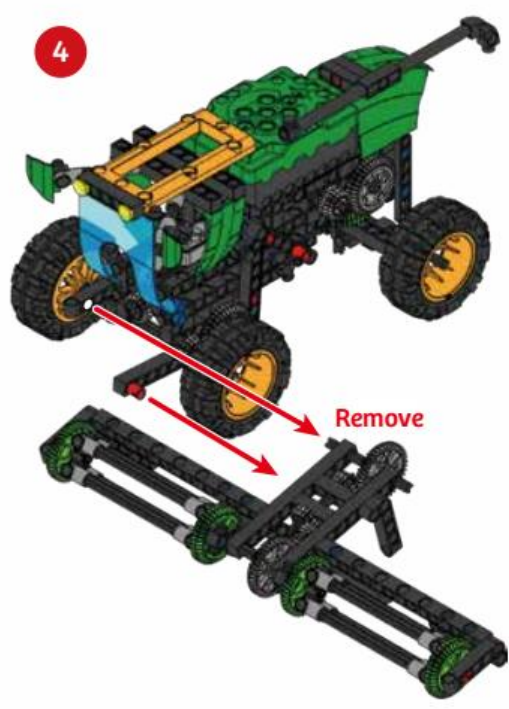

## COMBINE HARVESTER Model 6

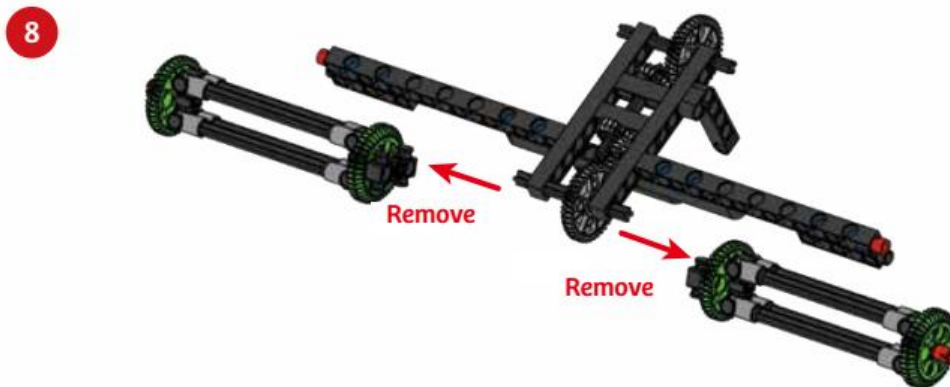
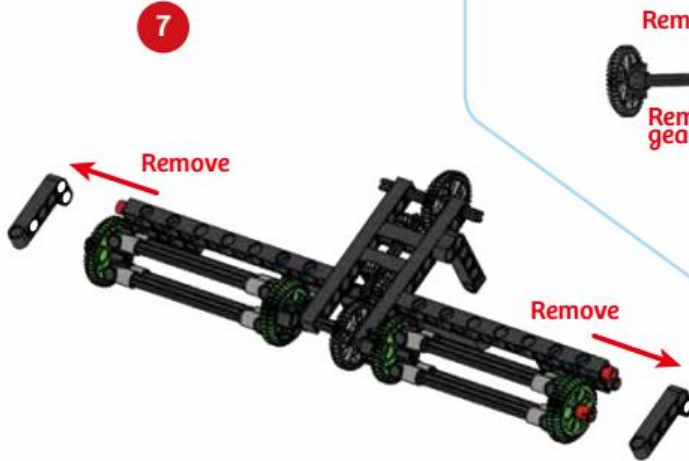
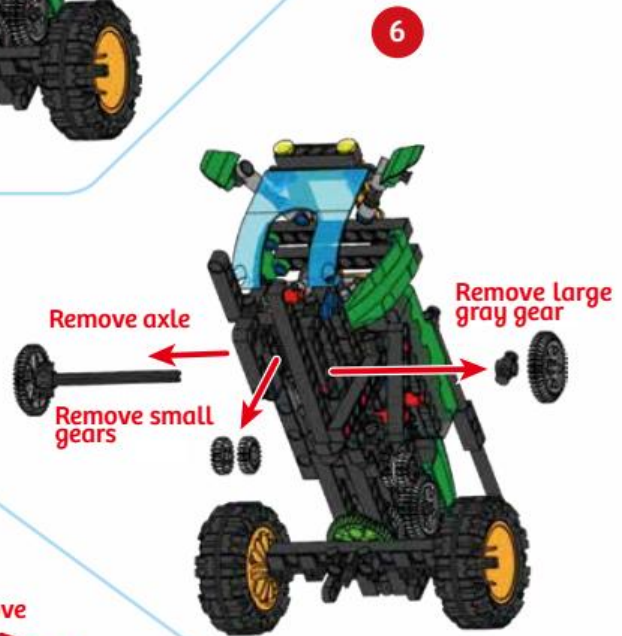
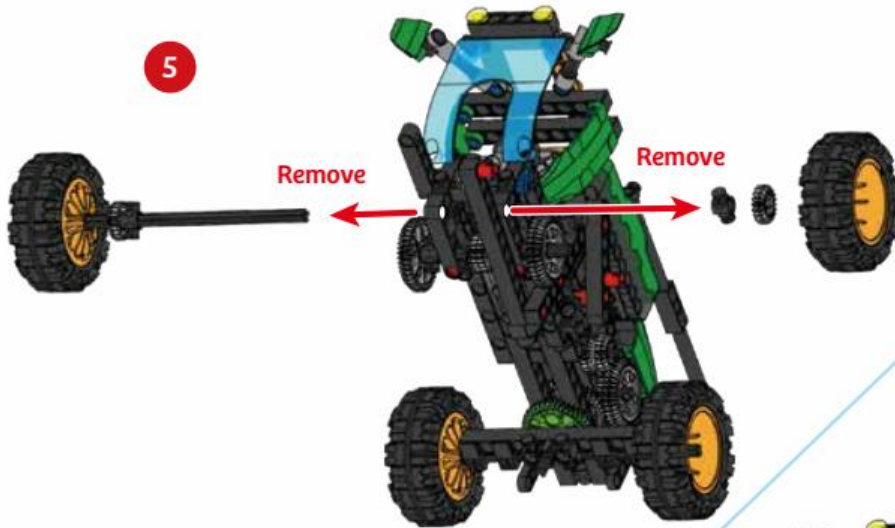



Model 6 COMBINE HARVESTER

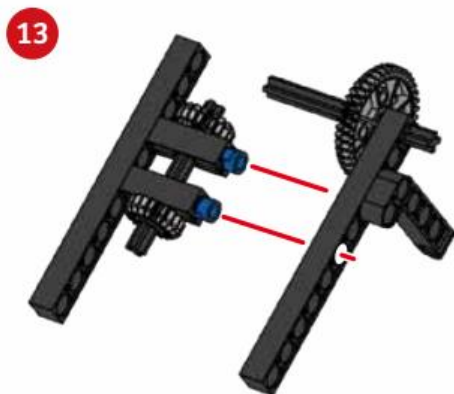
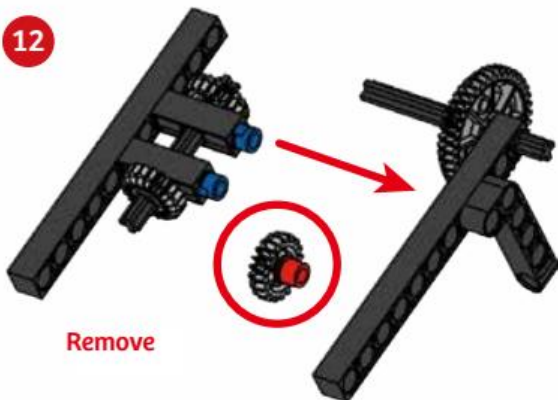
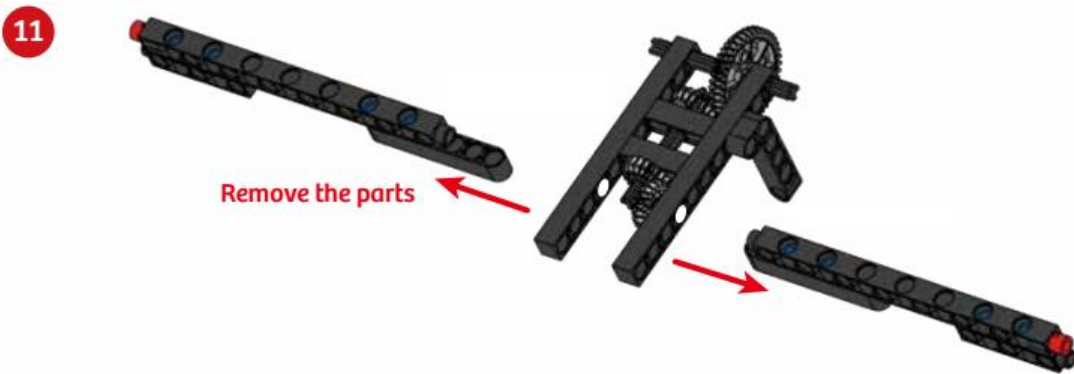
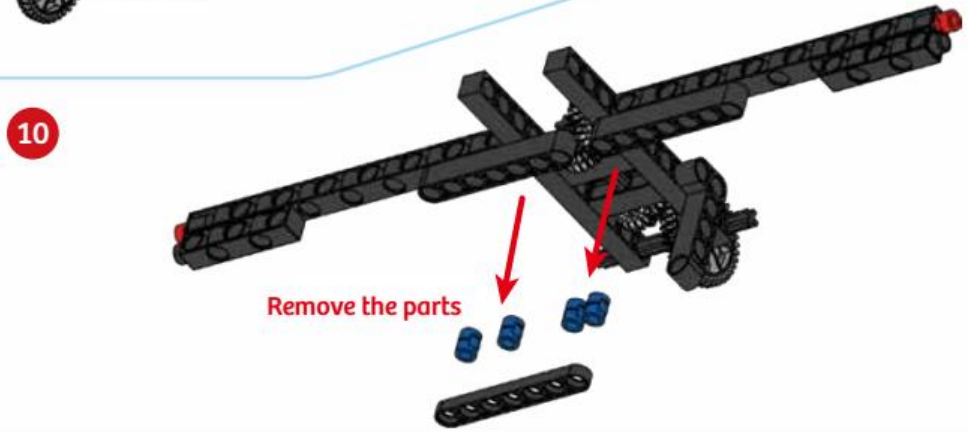
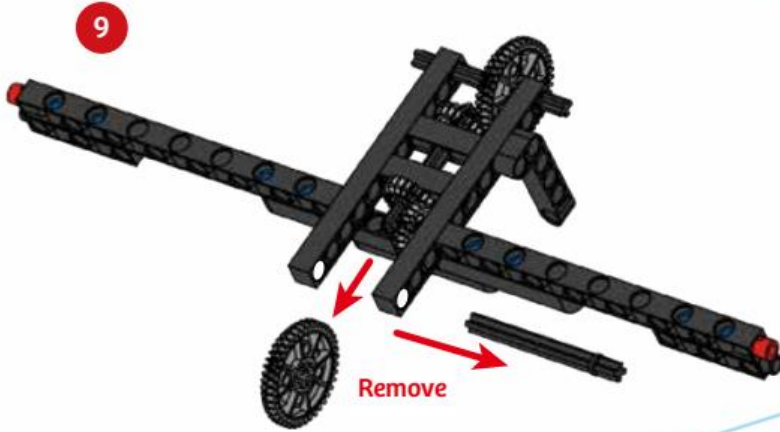

## COMBINE HARVESTER Model 6

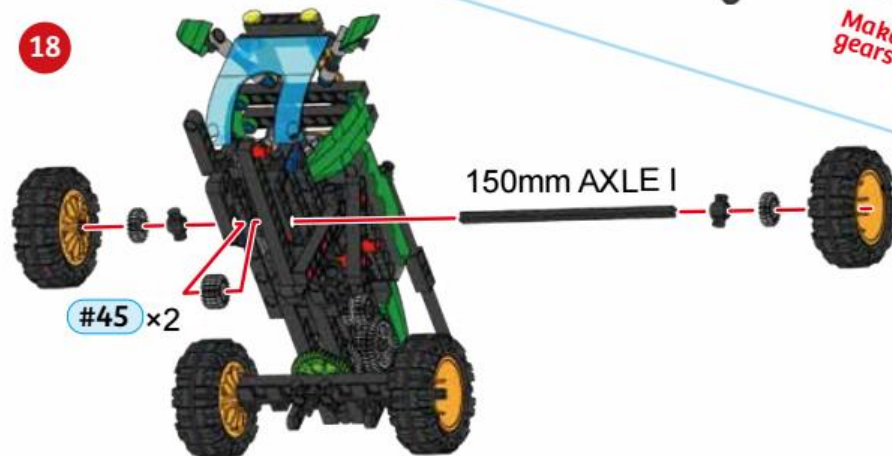
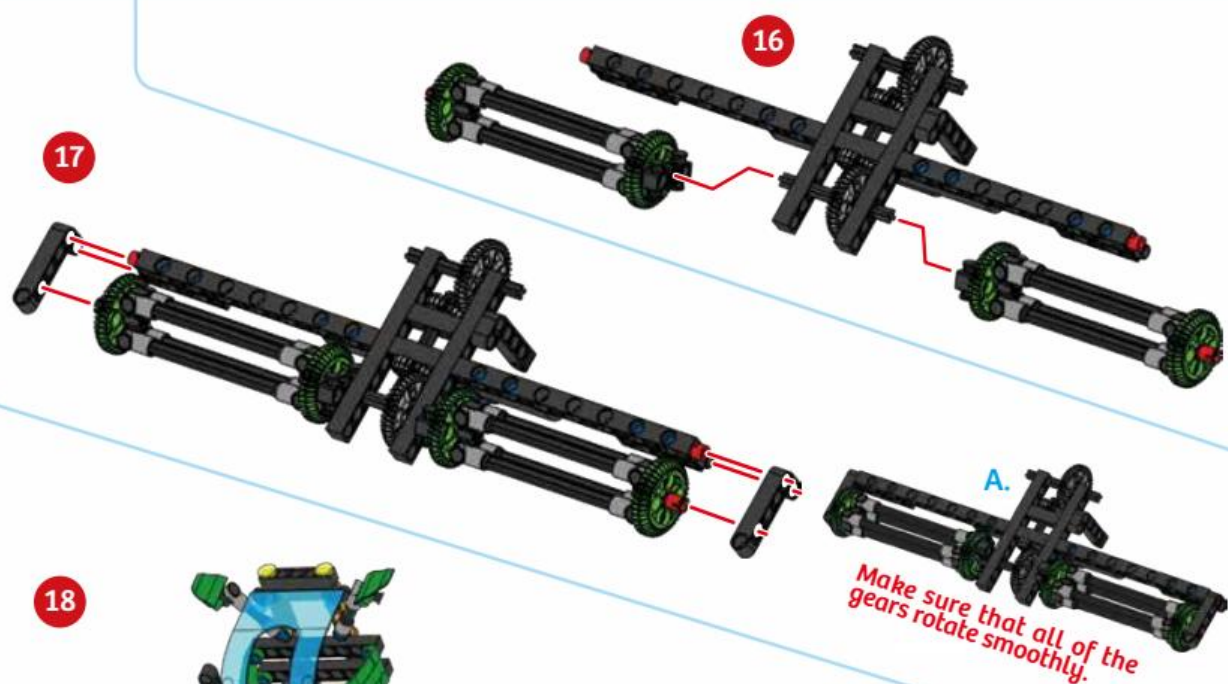
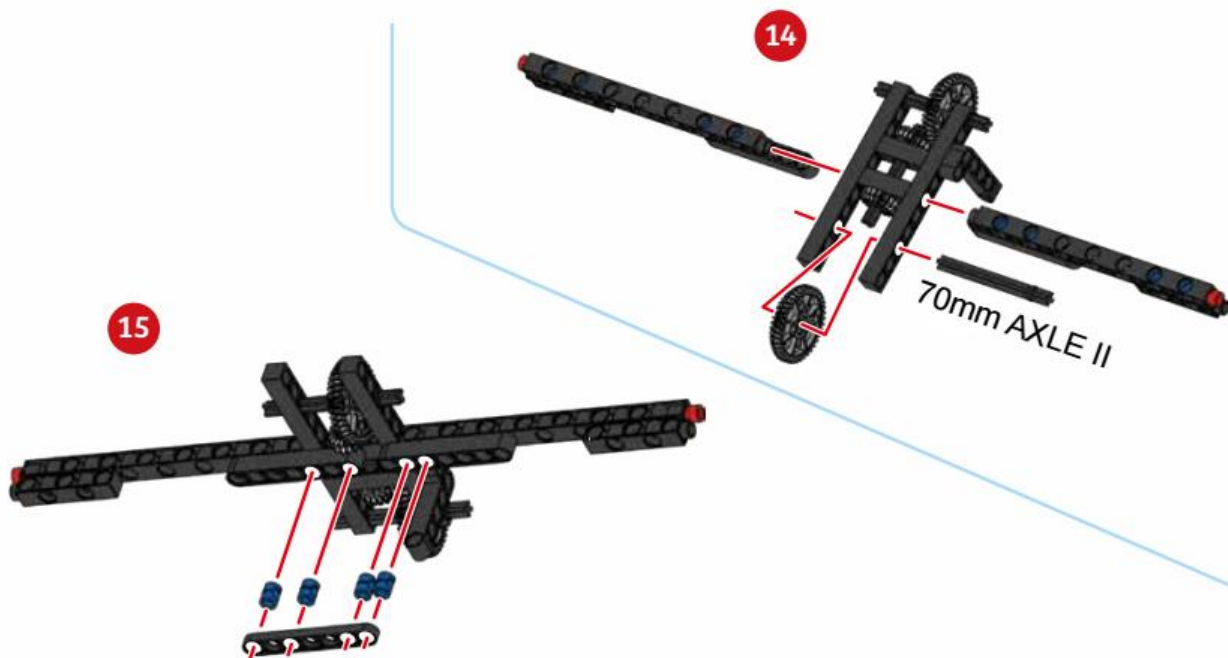

Model 6 COMBINE HARVESTER

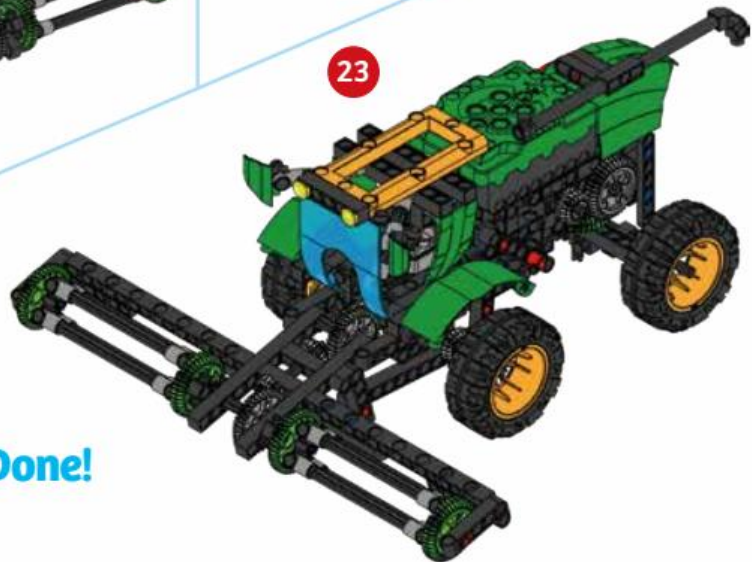
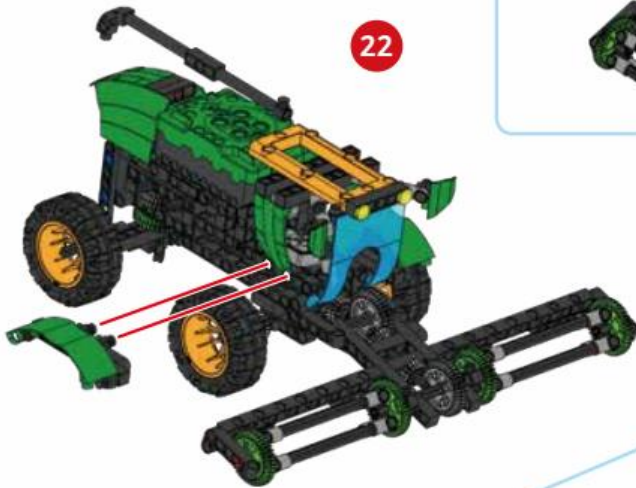
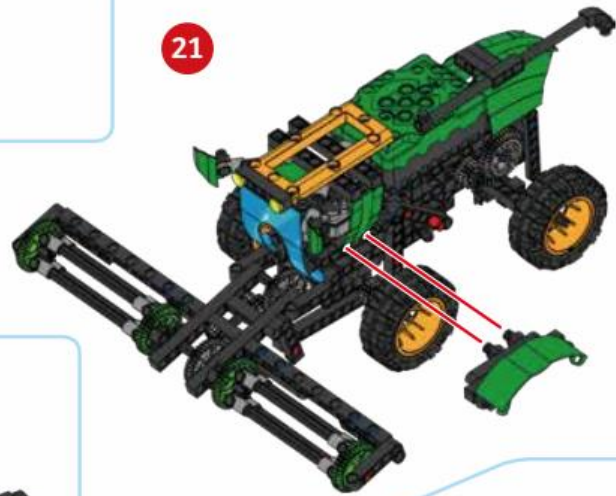
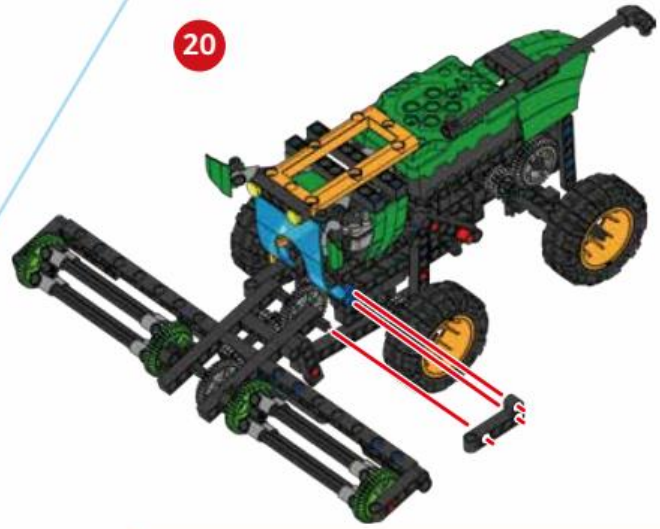
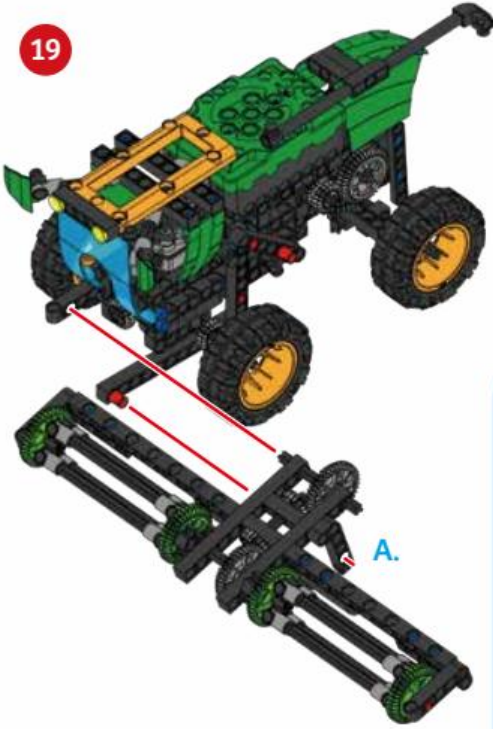

Done!

## CHECK IT OUT

## HOW A COMBINE HARVESTER WORKS

The edible **grain** portion of crops such as wheat, corn, barley, and rye are covered by an inedible casing called **chaff**. To use the grain it has to be separated from the chaff. Before the use of machines this was a very labor-intensive process. The combine harvester gets its name from the fact that it combines three processes in preparing grain crops: **reaping, threshing, and winnowing**.

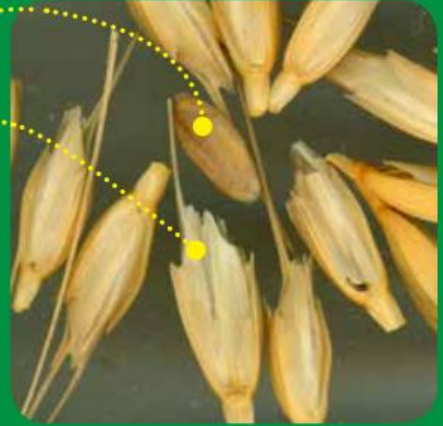

The first step in the process is to cut the grass when it is ripe, which is called **reaping**. At the front of the combine harvester is the **header**, which gathers the plants into the combine. Behind the header is the **cutter bar**, which functions like a giant electric razor and cuts the base of the plants.

The next step is to remove the head of the stalk and loosen the grain from the chaff by **threshing**, which is accomplished by hitting the grain against a surface. In a combine harvester this is done by the **threshing drum**. The threshing drum is a cylinder with large bars that hit the grain as the cylinder rotates at high speeds.

The grain is finally separated from the chaff by **winnowing**. Under the threshing drum, the grain and the chaff move over a grate. Air is blown through the chaff and grain, and the heavier grain falls through the grate while the chaff is blown toward the back of the combine.



## SIMPLE MACHINES: THE SCREW

Once the grain has been separated from the chaff, it is stored in a tank in the combine. When the tank is full, the grain is emptied into a trailer through a pipe called an **unloader**. Inside the pipe is a **screw or auger conveyor** which moves the grain up the tube. A screw is simply a spiral blade around a shaft. As the screw turns, it pushes the grain up along the tube.

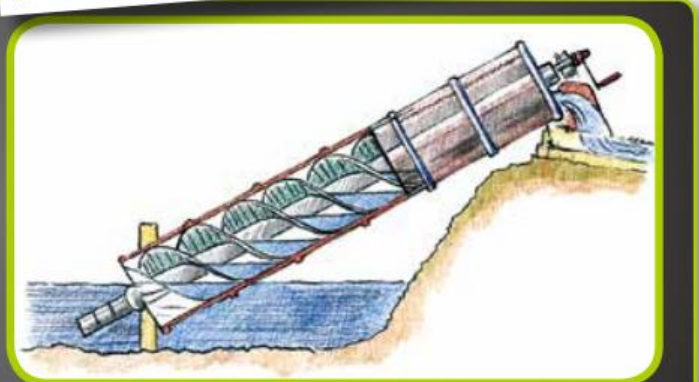

## Model 7 FARM TRUCK

### Parts Needed

Medium

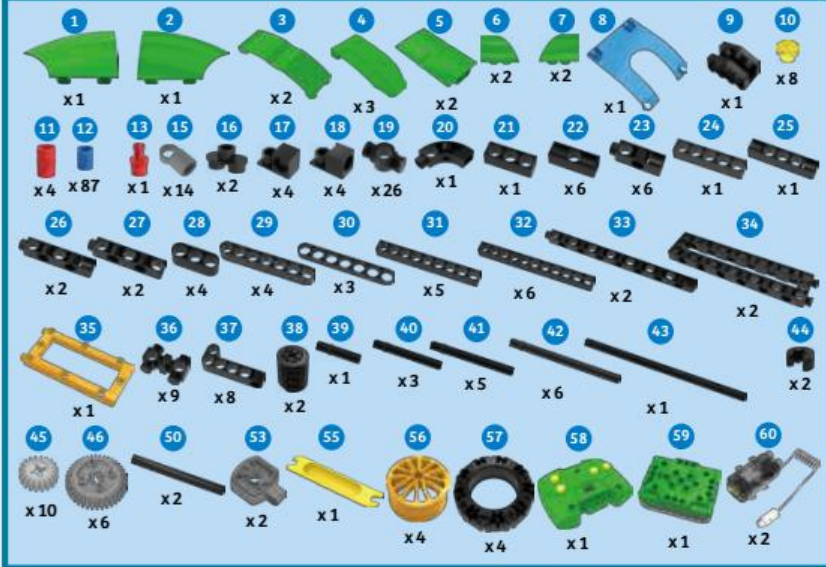

1



2

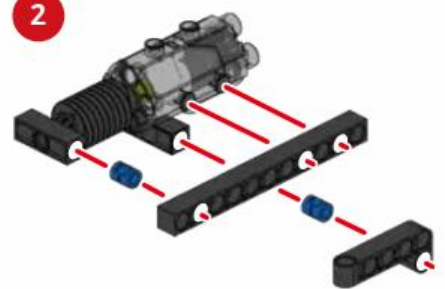

3

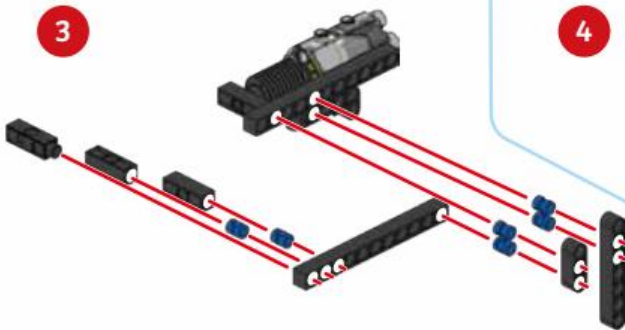

4

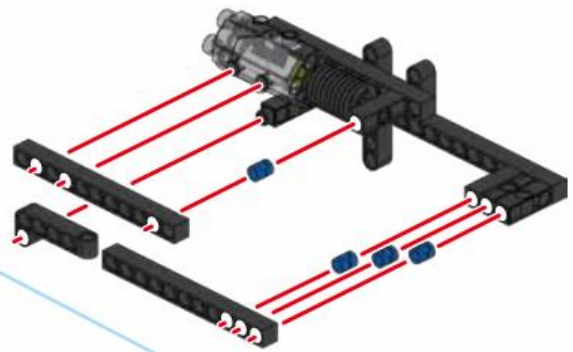

5

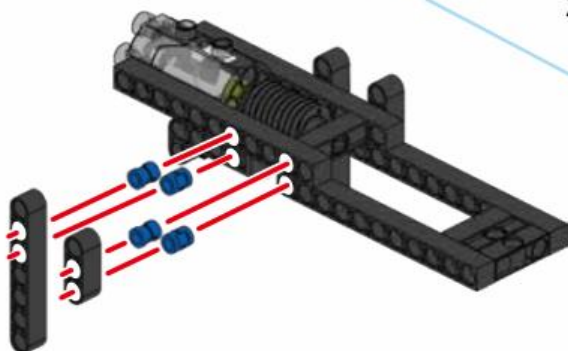

6

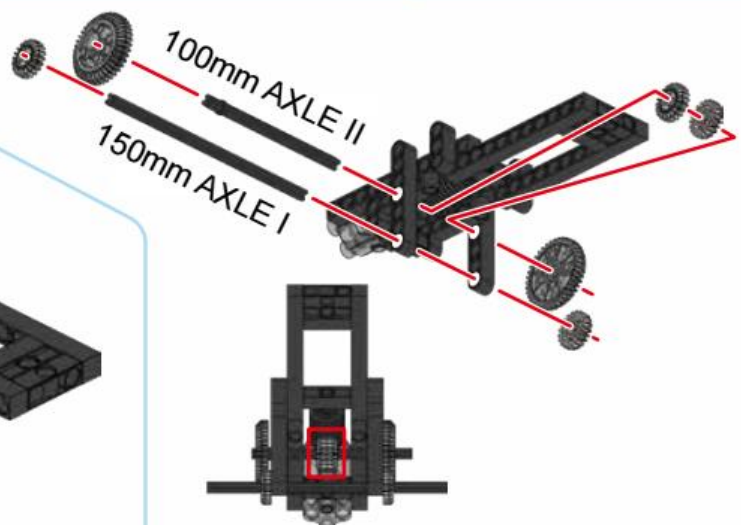

Place the 20T gears in the middle.

## FARM TRUCK Model 7

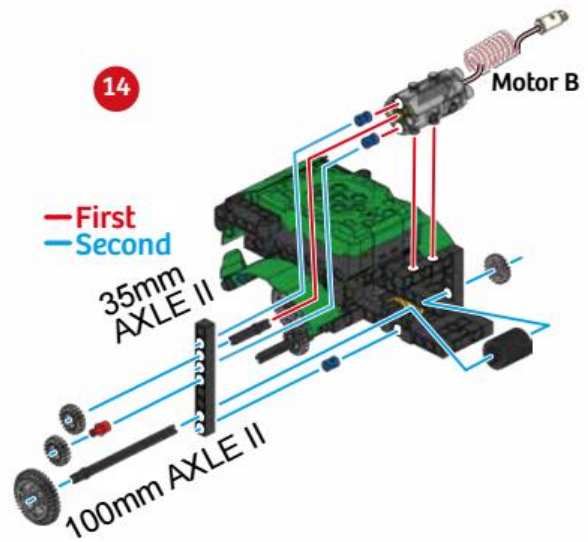
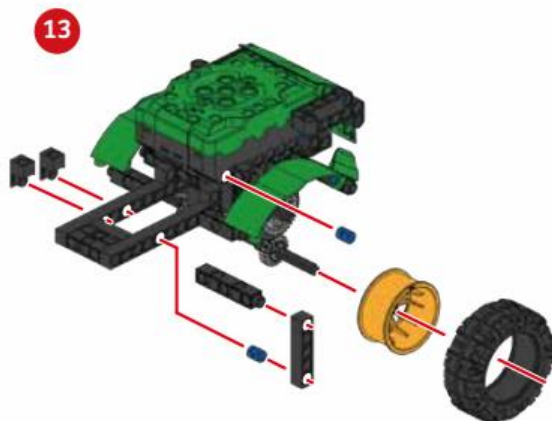
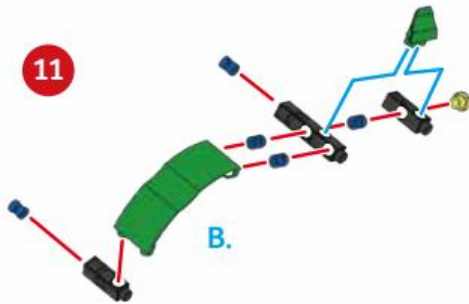
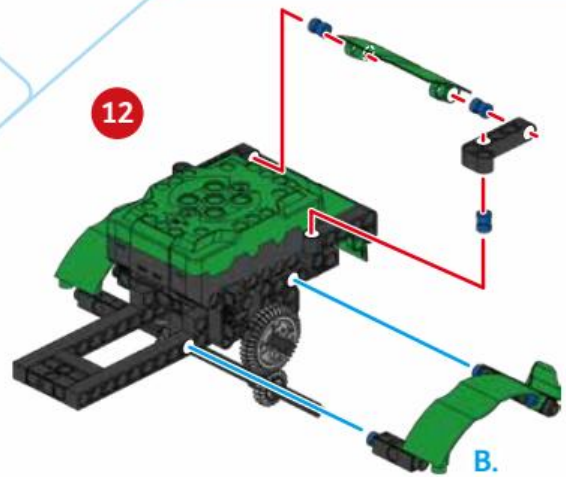
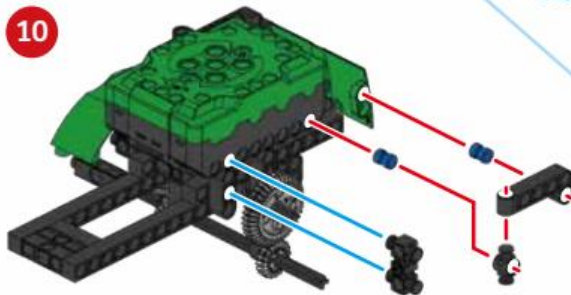
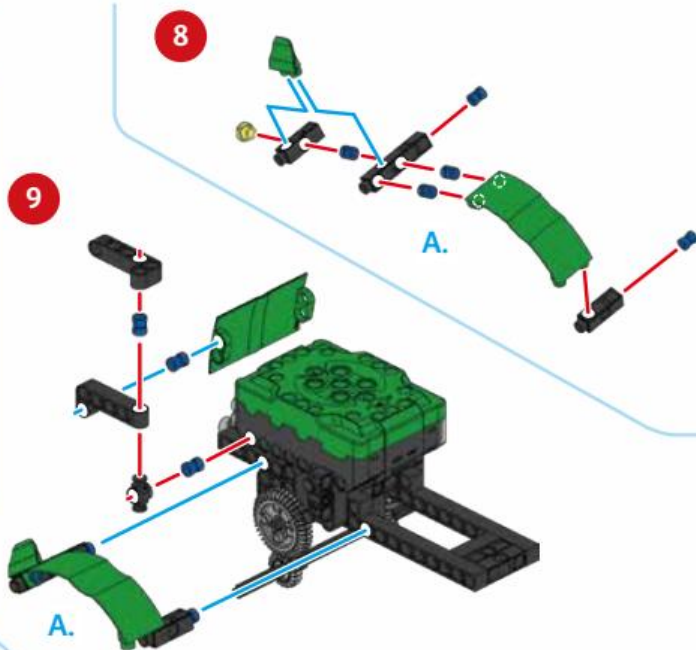
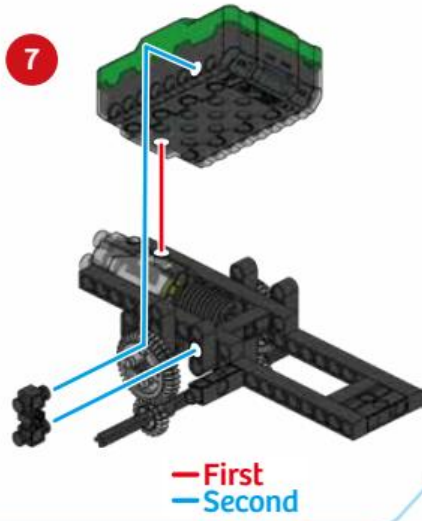

Model 7 FARM TRUCK

15

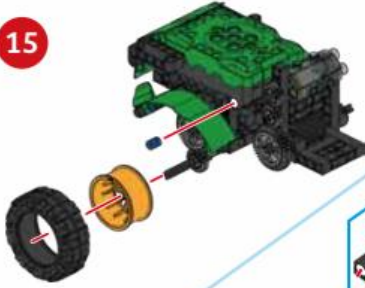

16

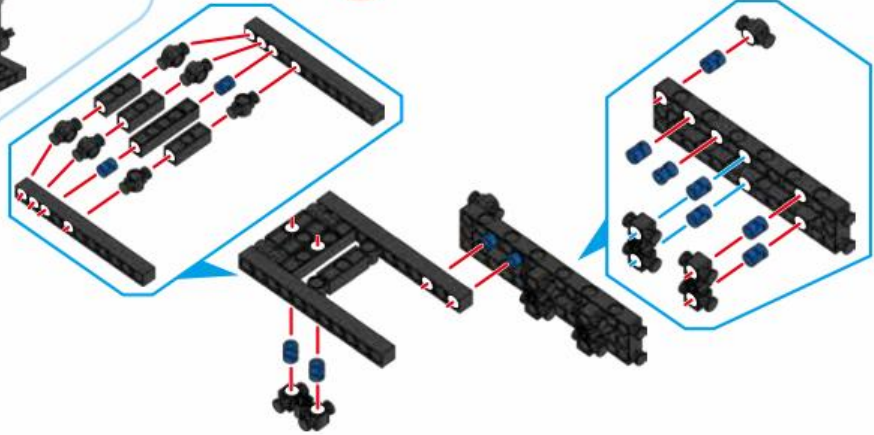

17

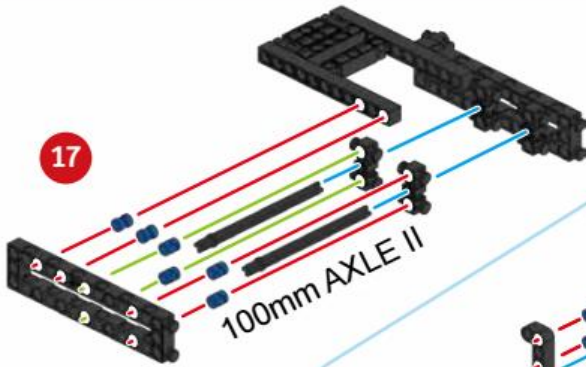

18

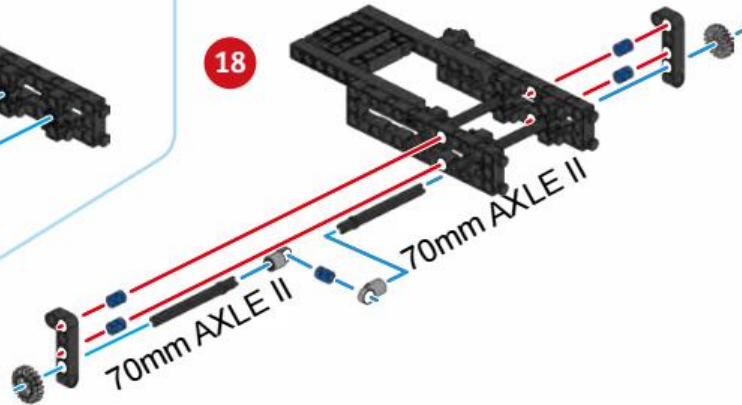

19

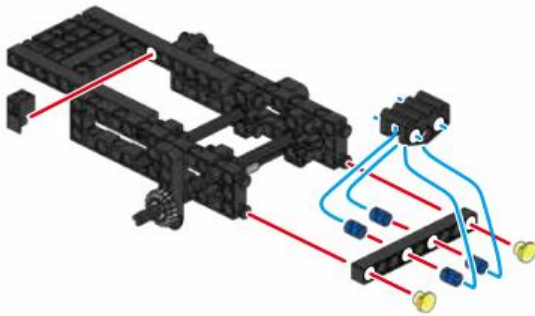

20

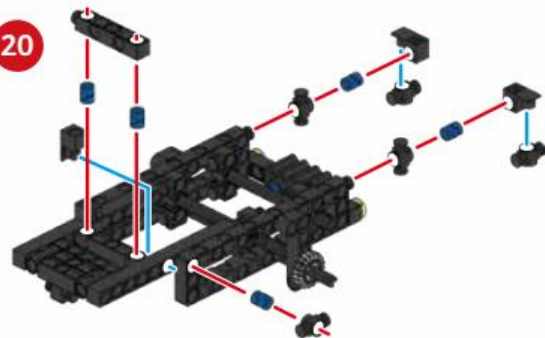

21

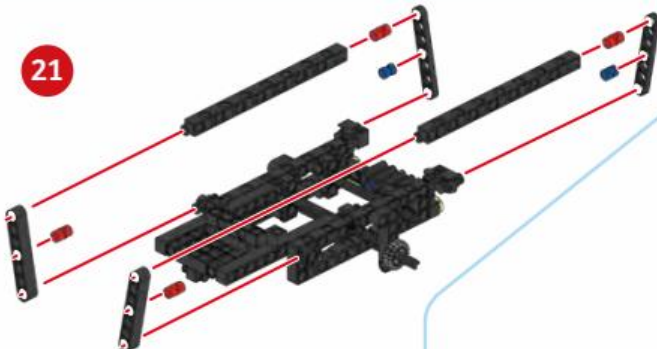

22



## FARM TRUCK Model 7

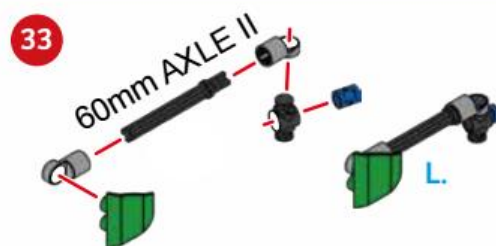
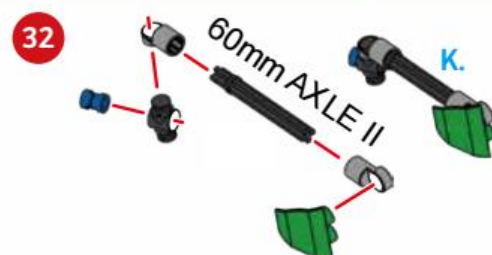
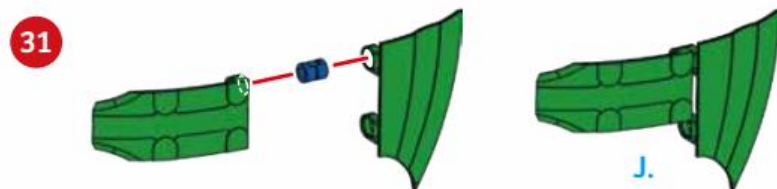
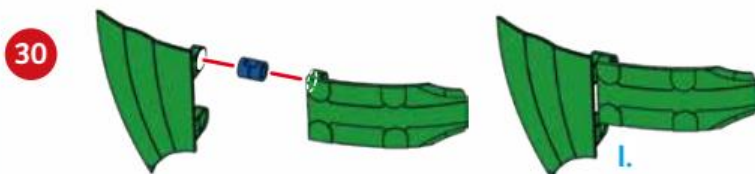
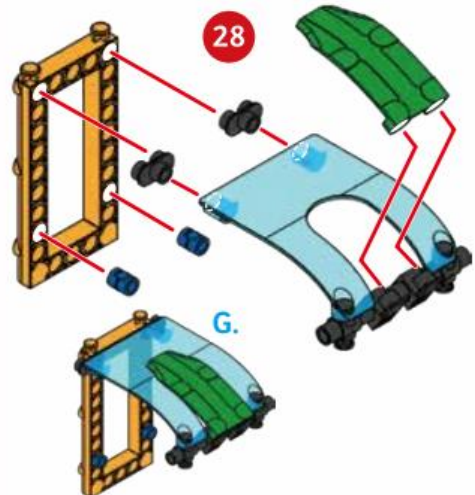
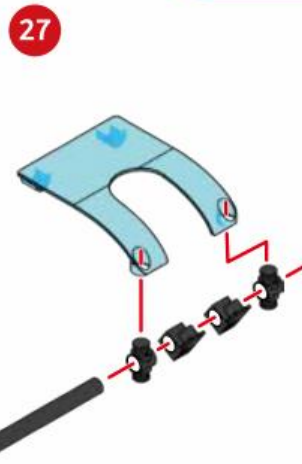
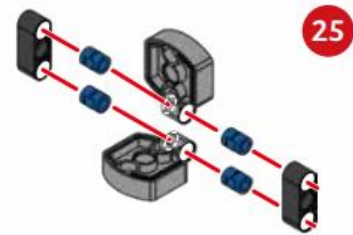
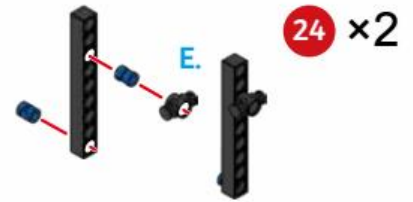
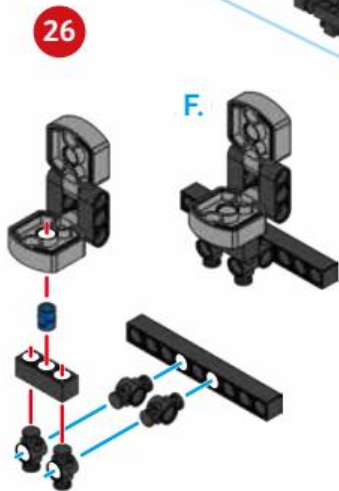
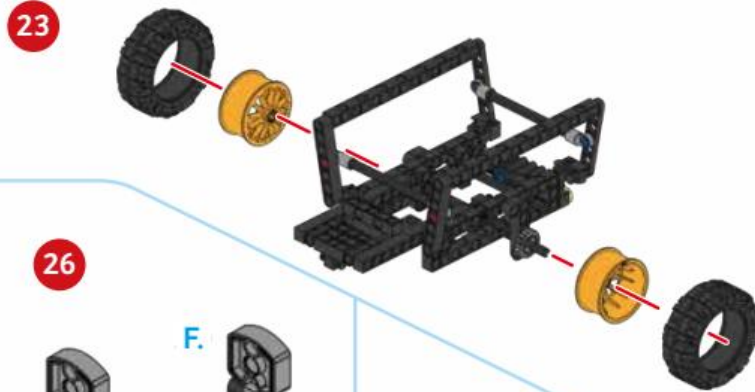



Model 7 FARM TRUCK

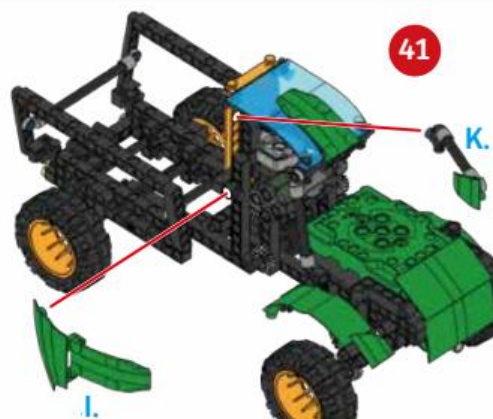
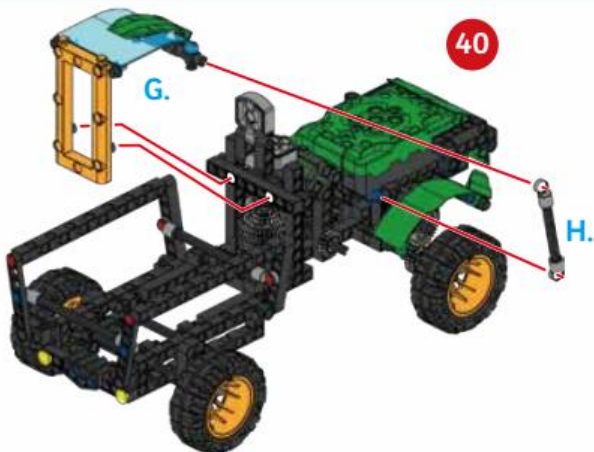
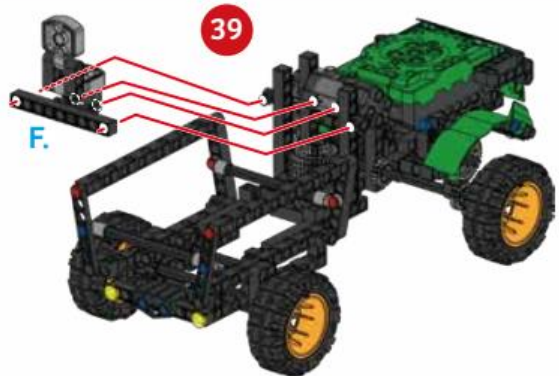
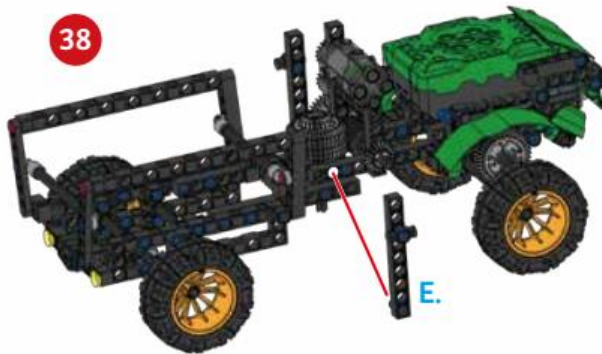
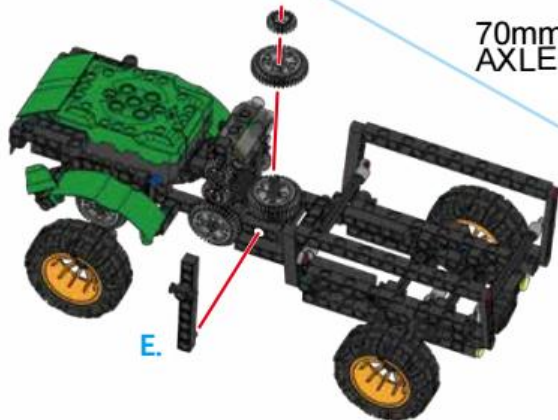
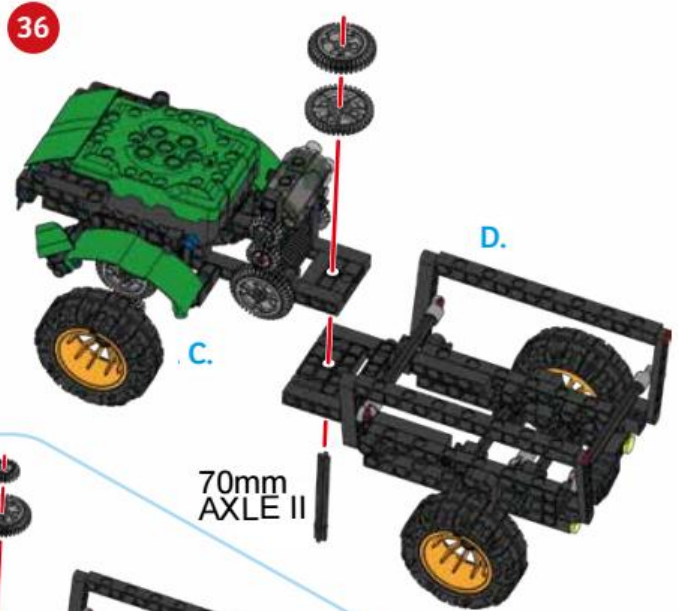
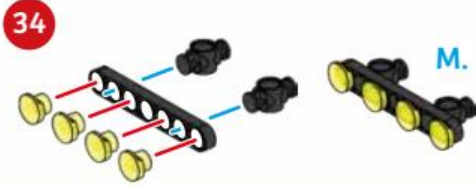

## FARM TRUCK Model 7

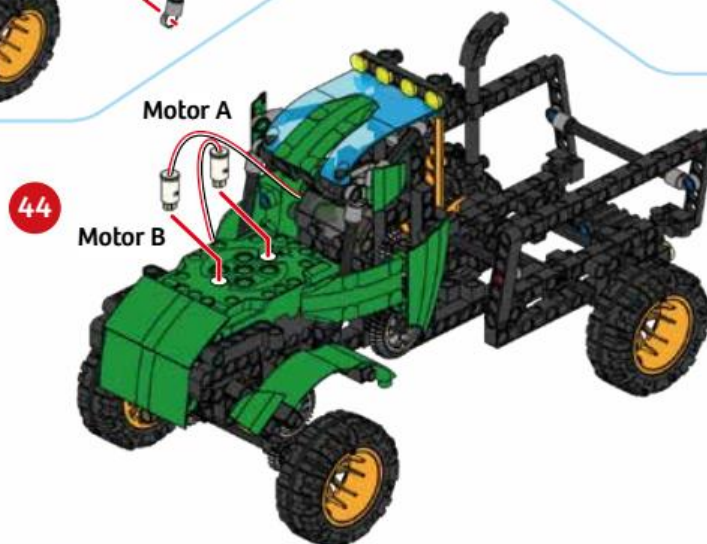
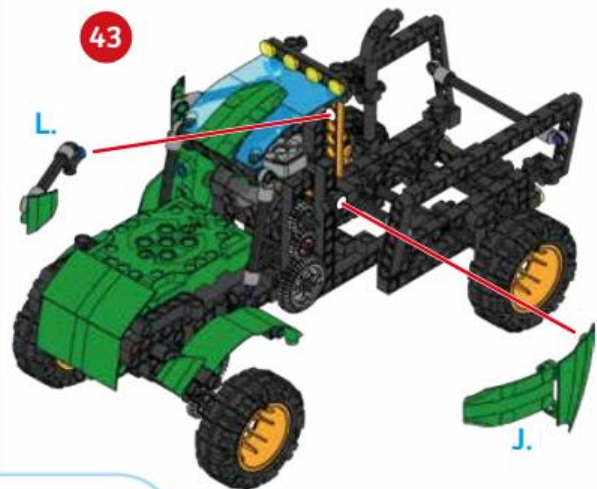
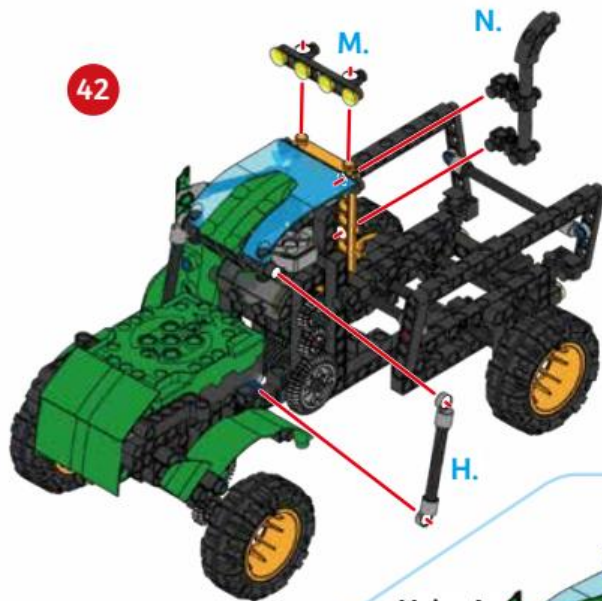

### EXPERIMENT 5

## Hauling materials

### HERE'S HOW

Set up an inclined plane (ramp) using materials like books and cardboard. Time how long it takes for the farm truck to go up the incline. Then place a small heavy object in the back of the farm truck and measure the time again. What happens to the amount of time it takes the truck to go up the inclined plane?



**Done!**

## CHECK IT OUT

# USING REMOTE-SENSING TECHNOLOGY

Modern farmers have access to much more information about their land and crops due to two important information systems: **Global Positioning Systems (GPS)** and **Geographic Information Systems (GIS)**. Using these systems, farmers are able to understand how different farming techniques influence their crops. This allows farmers to make better decisions about their land and water usage.

## GLOBAL POSITIONING SYSTEM (GPS)

The Global Positioning System, or GPS, is a navigation system, which is often used for getting turn-by-turn directions to a location. Many farmers now use GPS to make maps of their fields. This can be used to plan field boundaries, roads, and irrigation systems.

GPS is also used in farm equipment, such as tractors and combine harvesters, to keep track of where they have and haven't been. This allows farmers to follow the same path again and again with different machines. For example, after tilling the ground with a disc harrow, the farmer can follow the same path with a seeder. This ensures that the seeds are only placed in the areas that have been tilled.



## GEOGRAPHIC INFORMATION SYSTEMS (GIS)

GIS is a tool used to visualize and analyze geographical data. The power of GIS comes from its ability to analyze different types of data together. For example, a farmer can combine rainfall, elevation, slope, and soil-type data together using GIS to plan drainage and irrigation in a way that will prevent flooding.

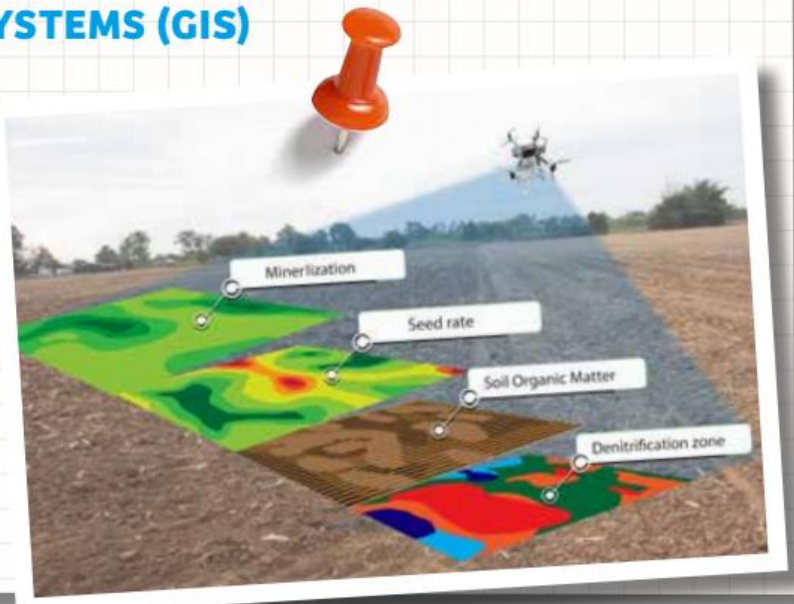

## WINDROWER Model 8

### Parts Needed

Medium

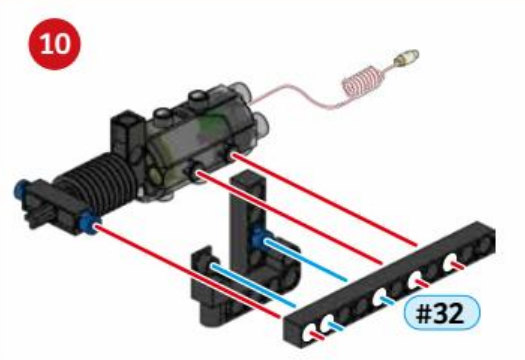
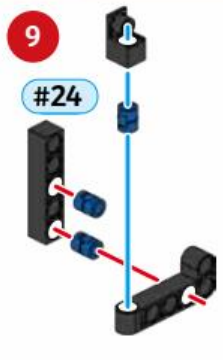
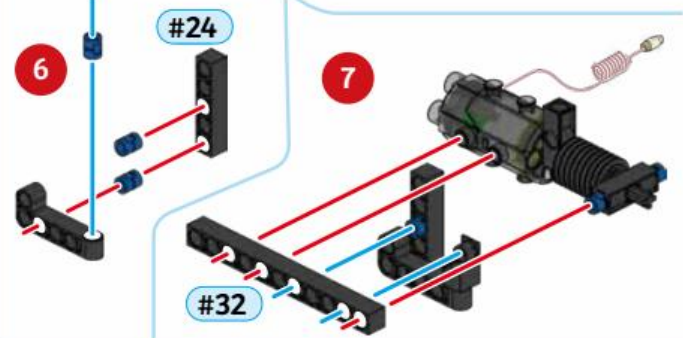
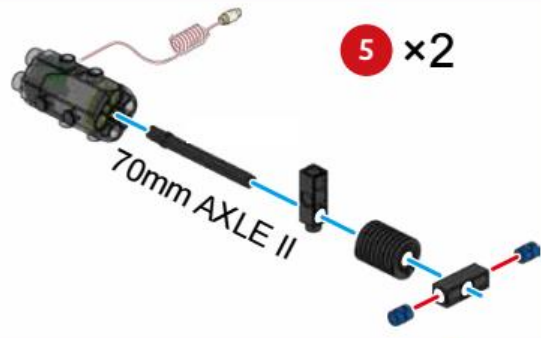
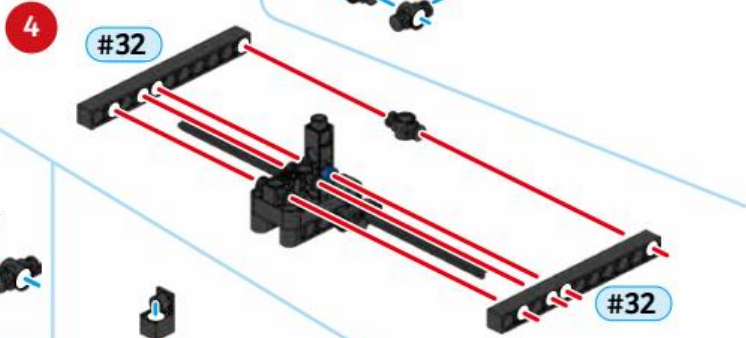
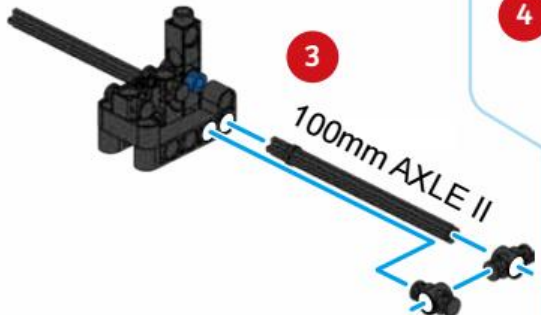
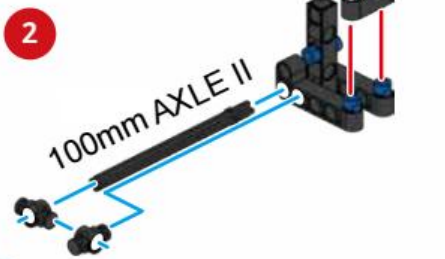
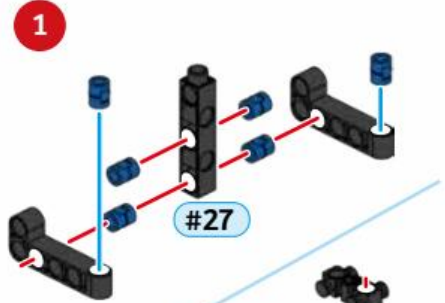

## Model 8 WINDROWER

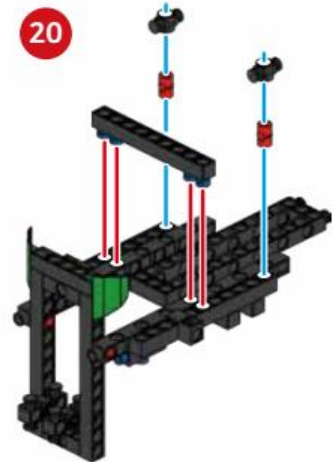
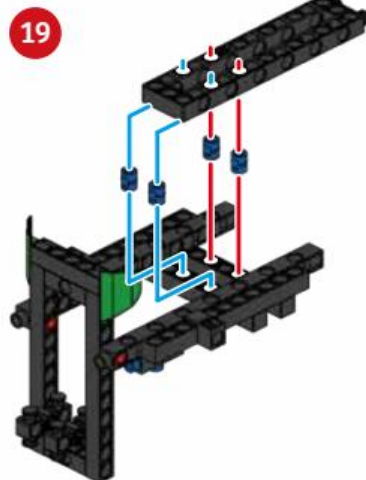
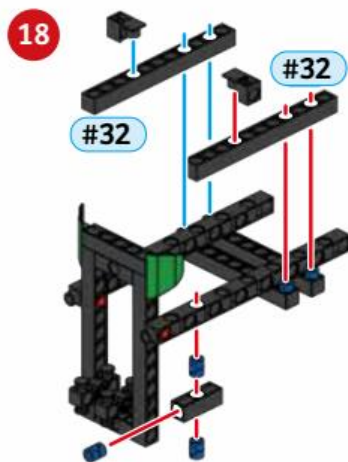
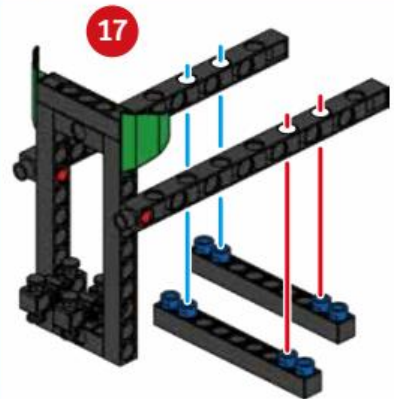
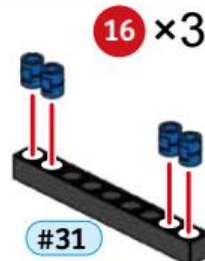
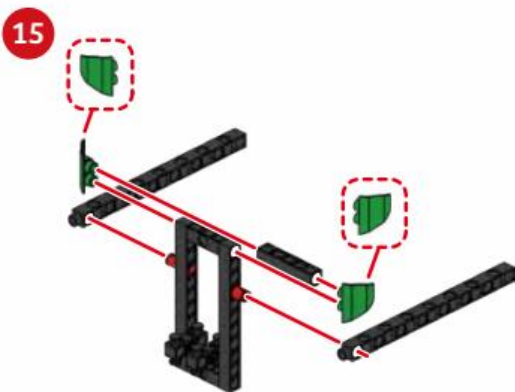
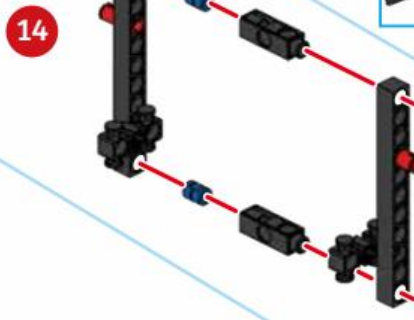
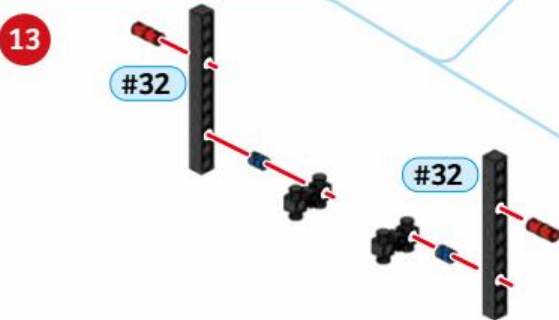
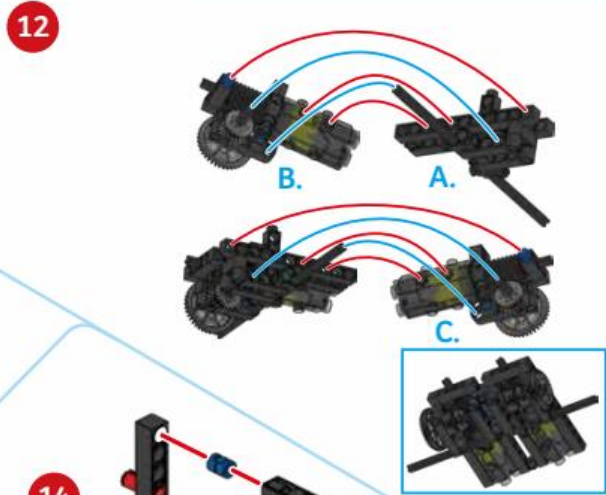
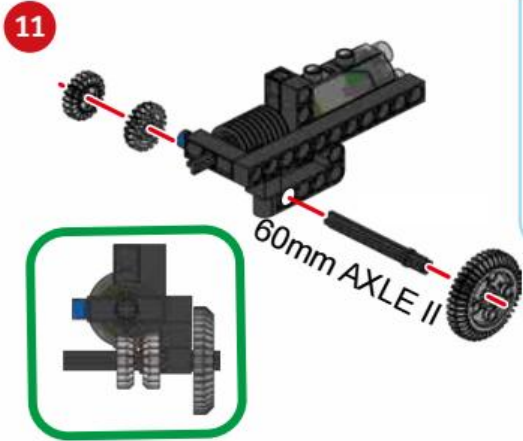

## WINDROWER Model 8

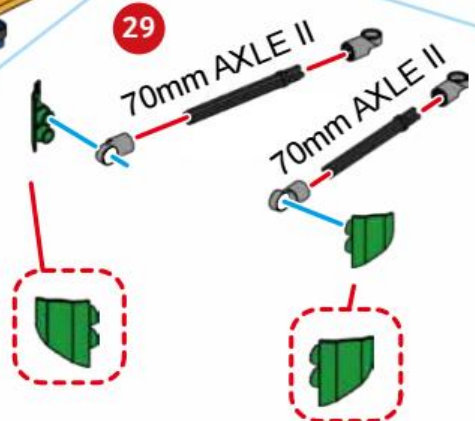
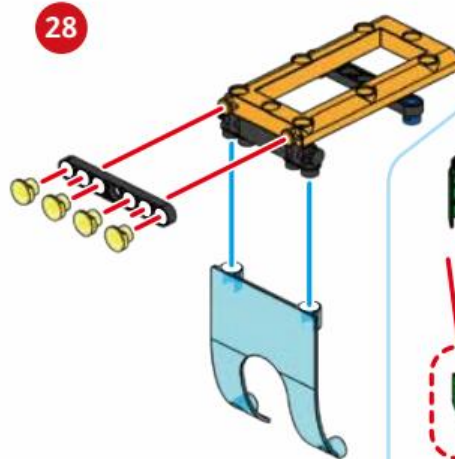
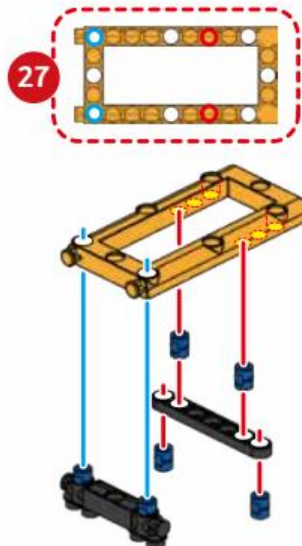
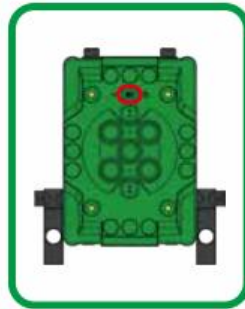
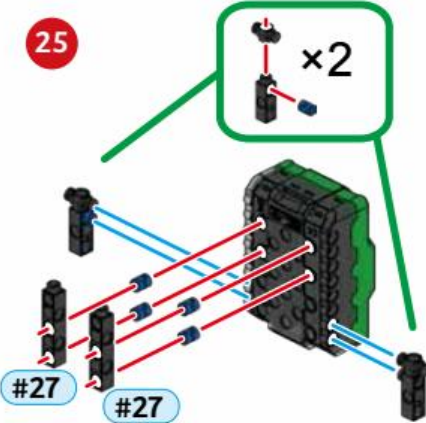
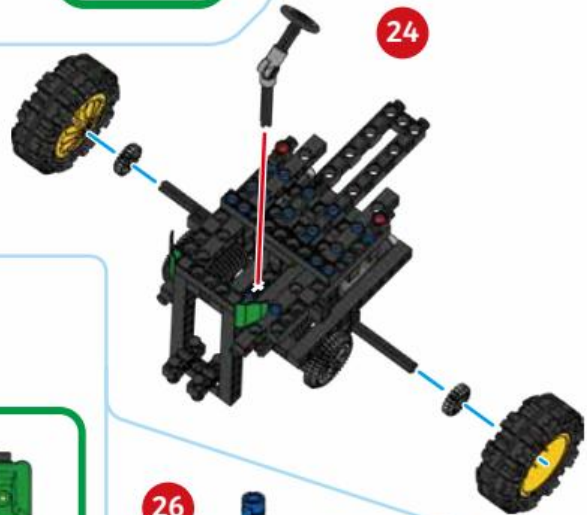
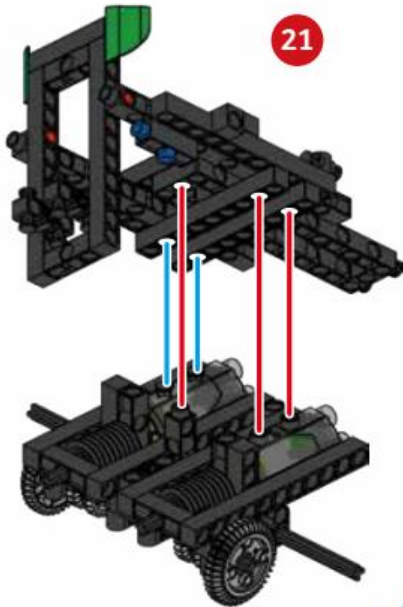

Model 8 WINDROWER

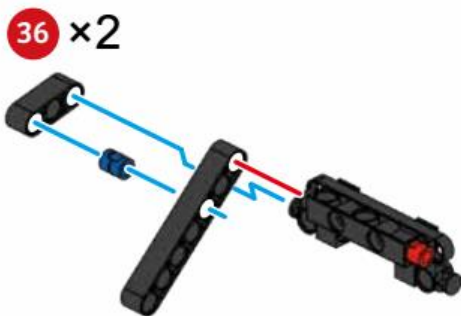
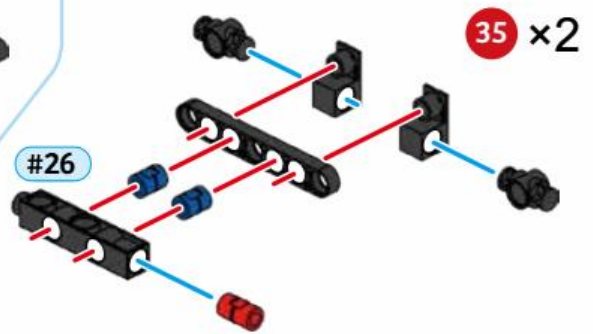
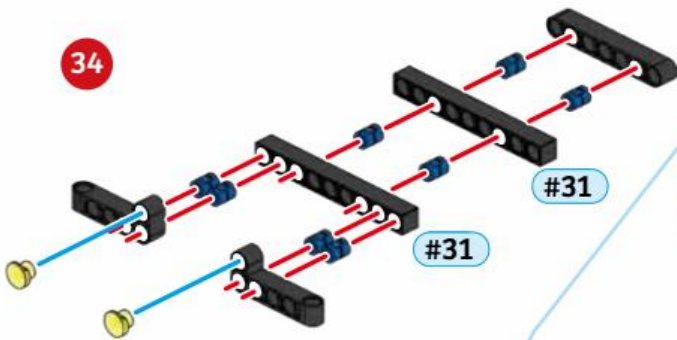
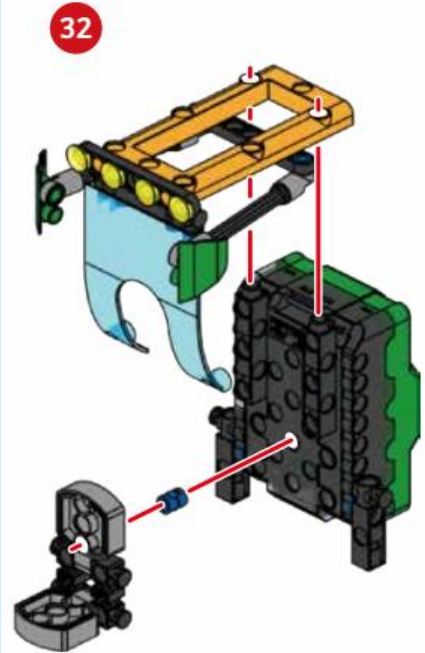
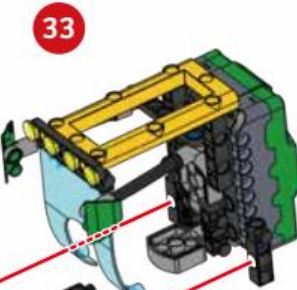
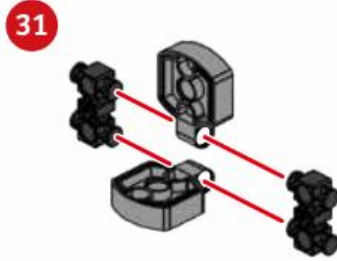
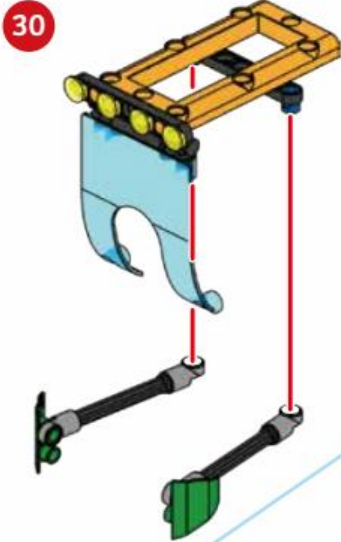

## WINDROWER Model 8

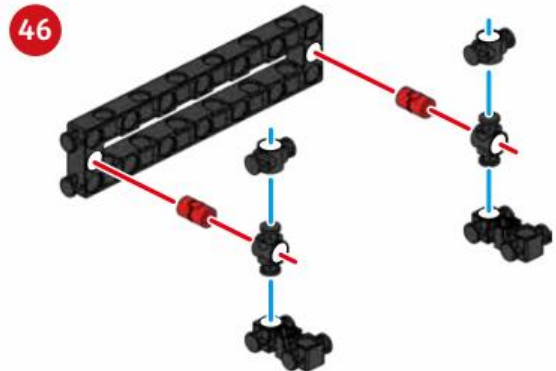
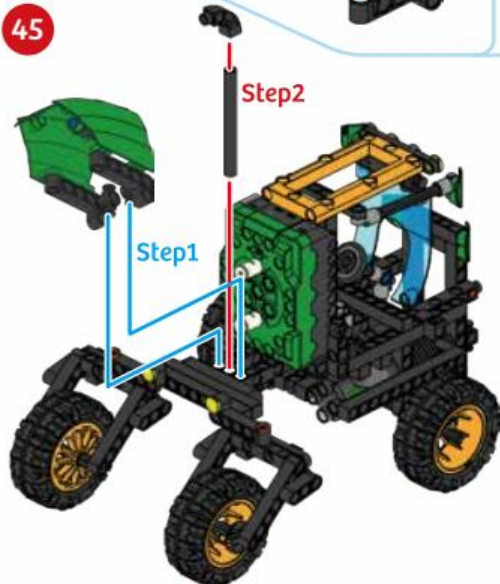
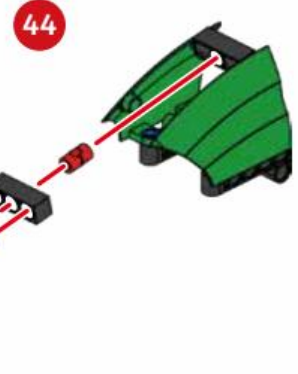
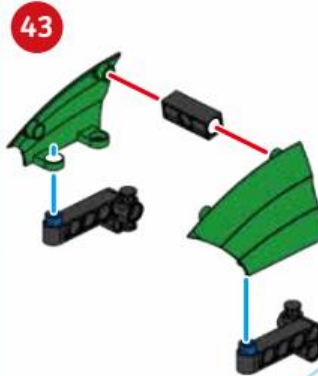
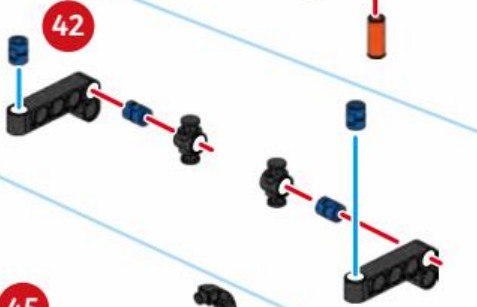
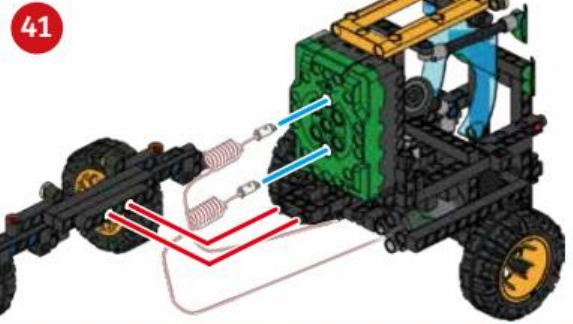
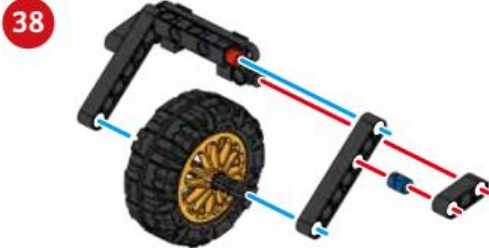



Model 8 WINDROWER

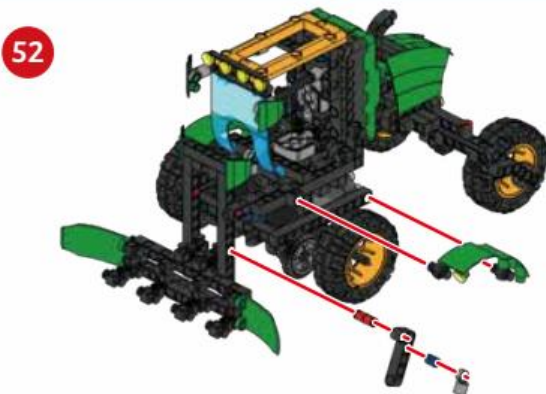
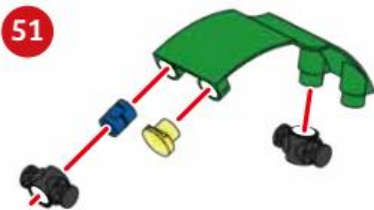
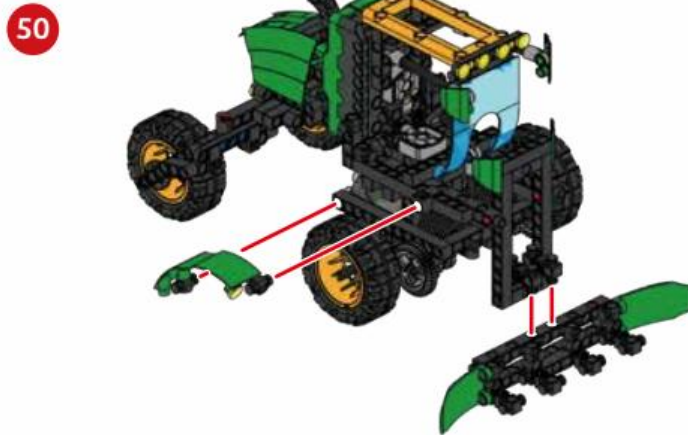
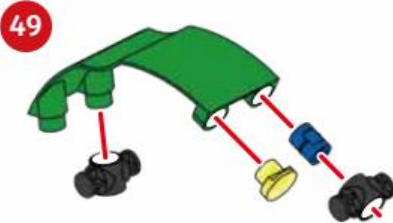
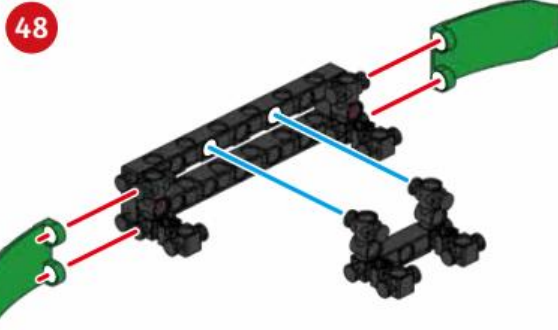
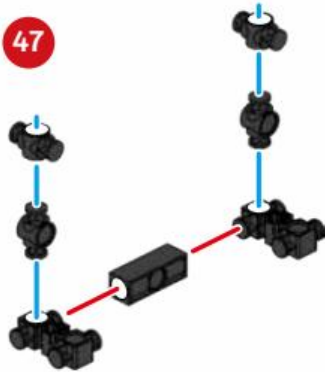

Use the handle to make the front of the windrower go up and down.

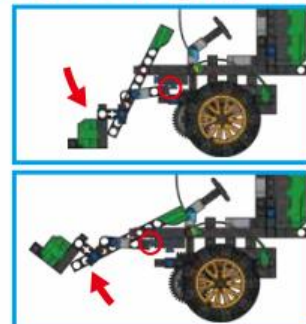

EXPERIMENT 6

Moving materials

HERE'S HOW

Place small, light objects around a room. Use the front of the windrower model to move all the objects into one area.



CHECK IT OUT

# THE FUTURE OF FARMING

As you have learned, agricultural machinery has made farming much easier and less labor-intensive. These machines have developed and changed over the last 150 years. This trend continues today with the development of new ways to automate farming using technologies such as driverless tractors and drones.



## DRIVERLESS TRACTORS



Driverless tractors are programmed to perform their tasks without the presence of a human. Driverless tractors have been developed within the last 10 years thanks to advances in computers, computer programming, and an increased reliance on GPS in farming.

Developing driverless tractors is challenging because they need to imitate human abilities such as visual observation and decision making. For example, driverless tractors must be able to determine their paths, react to unknown situations, and make decisions all in an appropriate amount of time. This is accomplished through the use of sensors that relay information to the

tractor, which is then processed by complex computer programs. For example, the position information from GPS is used by driverless tractors to determine the route and speed that the tractor should follow.

## DRONES

A new area of development in agricultural technology is the use of drones. In combination with sensors and imaging technology, drones can be used to gather information about fields. For example, drones can capture infrared and visual spectrum images of crop plants. Infrared light lies beyond the visual spectrum, or the light that human eyes can see. Using these images, farmers are able to tell if plants are healthy or unhealthy.





**Please browse website**



Gigo website



 Gigo FB

Welcome to our newly redesigned Gigo website!

- We now offer four language options (English, Traditional Chinese, Simplified Chinese, Russian).
- Many brilliant videos for product introduction.
- Online product brochures to facilitate timely Browse.

**Multi-Language**

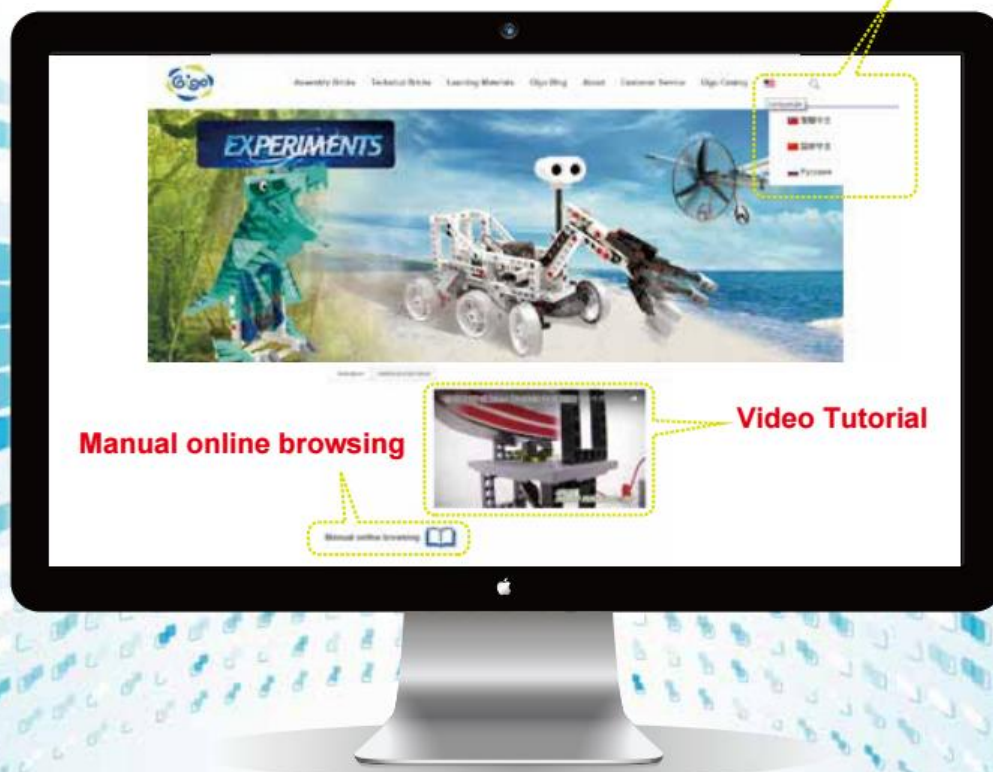

# EXPERIMENTS



STRUCTURAL ENGINEERING  
BRIDGES & SKYSCRAPERS  
#7410  
25 Models to build  
323 PCS



MECHANICAL ENGINEERING  
ROBOTIC ARMS  
#7411  
6 Models to build  
204 PCS



CROSSBOWS & CATAPULTS  
#7406  
10 Models to build  
110 PCS



RCM CONSTRUCTION VEHICLES  
#7408  
8 Models to build  
227 PCS



PHYSICS WORKSHOP  
#7441  
37 Models to build  
306 PCS



GECKOBOT  
#7409  
7 Models to build  
176 PCS



SOLAR POWER 2.0  
#7303  
10 Models to build  
120 PCS



WATER POWER  
#7323  
15 Models to build  
165 PCS



WIND TURBINE  
#7400  
5 Models to build  
77 PCS



MADE IN TAIWAN

**GENIUS TOY TAIWAN CO., LTD.**  
[www.gigotoys.com](http://www.gigotoys.com)

© 2018 Genius Toy Taiwan Co., Ltd. ALL RIGHTS RESERVED

R21#7447