



# RC RACE CAR

## EXPERIMENTS



# 7407

260 PCS

8+

**BUILD CUSTOM CARS  
WITH 3-SPEED GEAR BOX.**



**10 MODELS  
TO BUILD**





## >>> TABLE OF CONTENTS

### TIP!

You will find additional information in the "Check it out" sections on pages 14, 15, 21, 29, 30, 31, 39, 46, and 80.



### TIP!

Above each set of assembly instructions, you will find a red bar:

>>> It shows you the difficulty level for the model's assembly:



|                        |   |
|------------------------|---|
| Table of Contents..... | 1 |
| Tips and Tricks .....  | 2 |
| Kit Contents.....      | 3 |

### Introduction

|   |   |
|---|---|
| Engineering Different Cars for Different Uses ..... | 4 |
|---|---|

### Race Cars

Build a model of a sleek race car and a dragster to race around a track. Learn about the physics of cars and drag racing.

#### The models:

|                     |    |
|---------------------|----|
| Sleek race car..... | 5  |
| Dragster .....      | 16 |

### Luxury Cars

Construct a luxury super car and learn about how the gears, engines, and drive shafts of cars work.

#### The model:

|                |    |
|----------------|----|
| Super car..... | 22 |
|----------------|----|

### Classic Cars

Build a hot rod and a hot hatchback, and learn about some famous cars throughout history. Then learn about engineering a race car and build a speedy go-kart.

#### The models:

|                    |    |
|--------------------|----|
| Hot rod.....       | 32 |
| Hot hatchback..... | 40 |
| Go-kart .....      | 47 |

### Modern Cars

Build a pickup truck and a truck to move cargo around. Then build a buggy to drive up hills.

#### The models:

|                   |    |
|-------------------|----|
| Pickup truck..... | 52 |
| Truck.....        | 58 |
| Buggy.....        | 64 |

### Future Car

Construct an electric car and learn about some of the features that cars of the future might have.

#### The model:

|                   |    |
|-------------------|----|
| Electric car..... | 73 |
|-------------------|----|

|                               |    |
|-------------------------------|----|
| Publisher's Information ..... | 81 |
|-------------------------------|----|

|                          |    |
|--------------------------|----|
| Safety Information ..... | 82 |
|--------------------------|----|



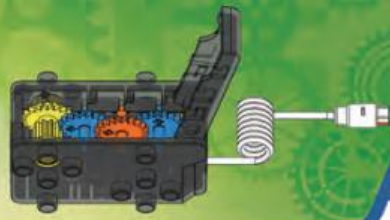

## >>> TIPS AND TRICKS

Here are a few tips for assembling and using the models. Read them carefully before starting.

### A. Changing the gear ratio

There are three different positions for the gears in the flex gear motor. Place the gears into the flex gear motor one at a time in the correct orientation, making sure that the gears are intermeshed with their neighboring gears. You will use three of the five gears each time. Which three gears you use depends on your desired gear ratio. The instructions for each model will tell you which gear configuration to use. When all three gears are correctly placed, close the lid.

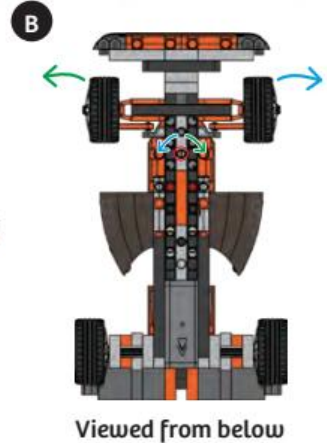
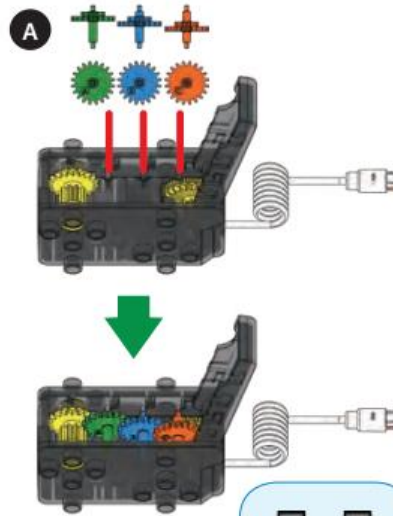

### B. Adjust the steering motor

If your model does not drive in a straight line you can adjust the alignment of the wheels. Locate the steering motor on the bottom of the IR steering motor. Use a flathead screwdriver to turn the screw. Turning the screw to the left will turn the wheels to the right, while turning it right will turn the wheels left. Make adjustments and test it.

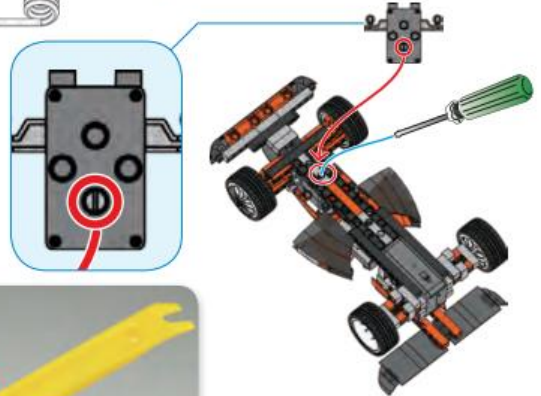

### C. The peg remover

The kit includes a yellow tool called the peg remover. End of the long peg makes it easy to remove long pegs from the frames.

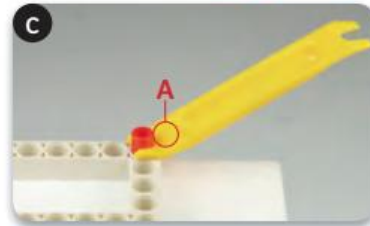

### D. Batteries in IR remote control unit

Open the battery compartment by unscrewing the screw and removing the cover. Insert two batteries, paying attention to the polarity indicated in the compartment and on the batteries. Close the compartment again and reinsert the screw to secure it.

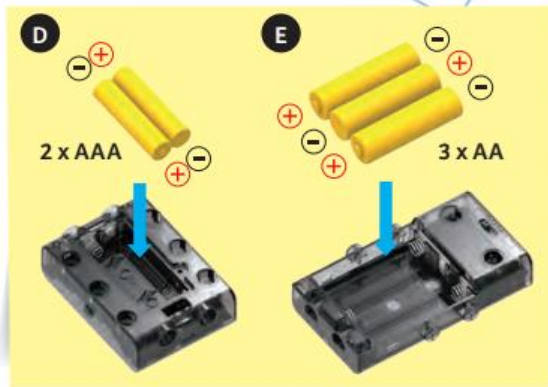

### E. Batteries in IR receiver

Insert the batteries according to their indicated plus-minus polarity. Close the compartment with the cover.

### F. Using the IR remote controller

To control a model, turn on both the motor unit and the remote control unit by moving their switches from the "off" position (0) to any of the four channels (1-4). The motor unit and the remote control must be set to the same channel to communicate. The channels enable you to use up to four models (sold separately) at the same time in the same space. One set of buttons on the controller unit drives the car forward and backward. The other set of buttons controls the car's steering.



### IMPORTANT!

Make sure your remote control unit and your motor unit are both set to the same channel (1-4) or else they will not work. When the remote control and motor are not in use, turn them off by setting their switches to "0" so as to not drain the batteries.







## What's inside your experiment kit:

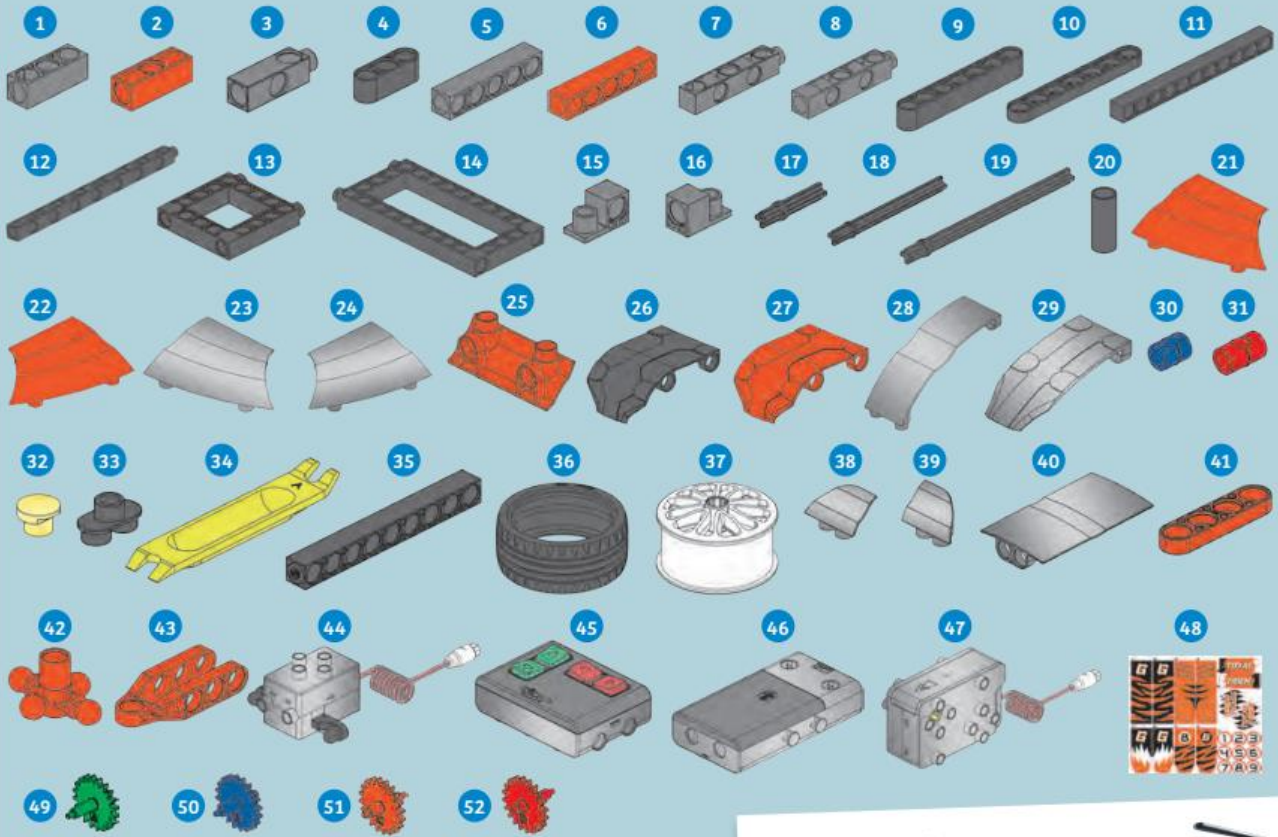

### You will also need:

2 x AAA batteries (1.5-volt, type AAA/LR03) and  
3 x AA batteries (1.5-volt, type AA/LR6)

## Checklist: Find – Inspect – Check off

| No. | Description                     | Qty. | Item No.      |
|-----|---------------------------------|------|---------------|
| 1   | C-3 hole rod lateral closed     | 13   | 7026-W10-Q2S2 |
| 2   | C-3 hole rod                    | 8    | 7026-W10-X10  |
| 3   | C-3 hole dual rod               | 2    | 7061-W10-R1S3 |
| 4   | C-3 hole round rod              | 4    | 7404-W10-C1D  |
| 5   | C-5 hole rod                    | 6    | 7413-W10-K2S2 |
| 6   | C-5 hole rod front closed       | 9    | 7413-W10-K3O1 |
| 7   | C-5 hole dual rod bottom closed | 2    | 7026-W10-S2S2 |
| 8   | C-5 hole dual rod               | 4    | 7026-W10-S3S3 |
| 9   | C-7 hole round rod              | 4    | 7404-W10-C2D  |
| 10  | C-7 hole prolate rod            | 4    | 7404-W10-C3D  |
| 11  | 11-hole rod                     | 2    | 7413-W10-P1D  |
| 12  | C-15 hole dual rod              | 2    | 7413-W10-H1D  |
| 13  | C-5x5 frame                     | 2    | 7026-W10-T2D  |
| 14  | C-5x10 frame                    | 2    | 7413-W10-I1D  |
| 15  | C-lateral converter             | 6    | 7061-W10-J1S3 |
| 16  | C-front converter               | 6    | 7061-W10-J2S3 |
| 17  | C-35 mm axle II                 | 2    | 7413-W10-O1D  |
| 18  | C-70 mm axle II                 | 2    | 7061-W10-Q1D  |
| 19  | C-100 mm axle II                | 2    | 7413-W10-L2D  |
| 20  | C-od8x20 mm tube                | 12   | 7400-W10-G2D  |
| 21  | C-shell a left                  | 3    | 7392-W10-L10  |
| 22  | C-shell a right                 | 3    | 7392-W10-L20  |
| 23  | C-shell a left                  | 1    | 7392-W10-L1TD |
| 24  | C-shell a right                 | 1    | 7392-W10-L2TD |
| 25  | C-shell c                       | 4    | 7392-W10-M10  |
| 26  | C-shell b                       | 4    | 7392-W10-J1D  |

| No. | Description                         | Qty. | Item No.      |
|-----|-------------------------------------|------|---------------|
| 27  | C-shell b                           | 2    | 7392-W10-J10  |
| 28  | C-shell f                           | 2    | 7398-W10-C1TD |
| 29  | C-shell e                           | 2    | 7398-W10-C2TD |
| 30  | B-short peg                         | 59   | 7344-W10-C2B  |
| 31  | C-long peg                          | 42   | 7061-W10-C1R  |
| 32  | C-short button fixer                | 4    | 7061-W10-E1TY |
| 33  | C-two-in-one converter              | 4    | 7061-W10-G1D  |
| 34  | B-peg remover                       | 1    | 7061-W10-B1Y  |
| 35  | C-9 hole rod                        | 2    | 7407-W10-C1D  |
| 36  | C-turbo tire                        | 4    | 7407-W10-A1D  |
| 37  | C-turbo tire rim                    | 4    | 7407-W10-B1W  |
| 38  | C-shell i l                         | 2    | 7407-W10-D2TD |
| 39  | C-shell i r                         | 2    | 7407-W10-D3TD |
| 40  | C-shell i j                         | 2    | 7407-W10-D1TD |
| 41  | C-4-hole prolate rod for ball joint | 2    | 7407-W10-F2D  |
| 42  | C-x shape ball joint                | 2    | 7407-W10-F10  |
| 43  | C-u shape connector for ball joint  | 4    | 7407-W10-E10  |
| 44  | C-steering motor                    | 1    | 7407-W85-A    |
| 45  | C-IR remote controller              | 1    | 7407-W85-C    |
| 46  | C-IR receiver                       | 1    | 7407-W85-D    |
| 47  | C-flex gear motor                   | 1    | 7407-W85-B    |
| 48  | Electrostatic sticker sheet         | 1    | R20#7407-US   |
| 49  | C-flex gear a                       | 1    | 7407-W10-O1G  |
| 50  | C-flex gear b                       | 2    | 7407-W10-O2B  |
| 51  | C-flex gear c                       | 1    | 7407-W10-O30  |
| 52  | C-flex gear d                       | 1    | 7407-W10-O4R  |

620376-02-270516



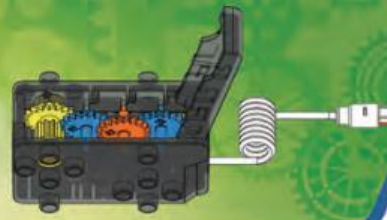

# Engineering Different Cars for Different Uses

There are many different types of cars, from Formula One race cars to pickup trucks. Each car looks different and they all have different functions. When designing and building these cars, engineers take these differences into account. However, all cars are subject to the same laws of physics, which govern their design. In this kit, you will build ten models of different types of cars and learn about some of the engineering that goes into designing a car.







### Sleek Race Car Model 1

#### Parts Needed

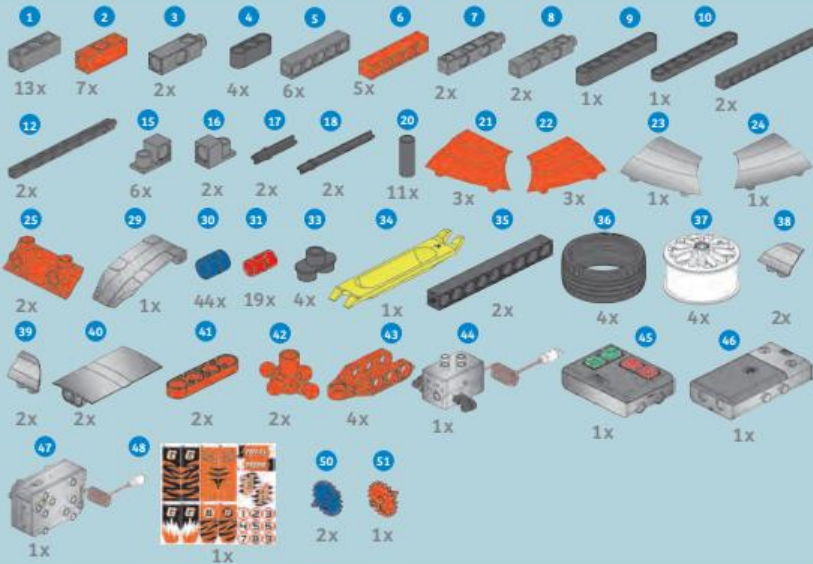

1 x2

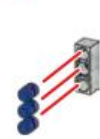

2



3 x2

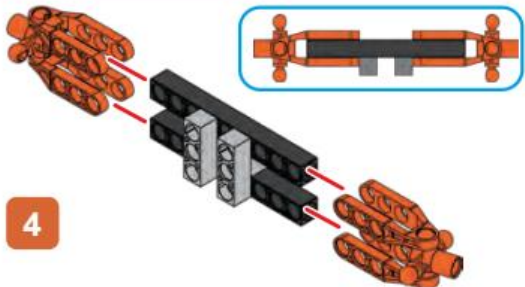
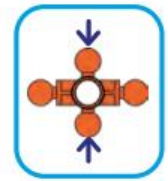
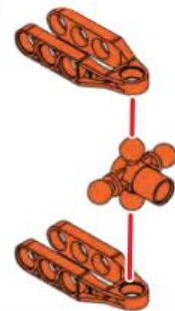

5

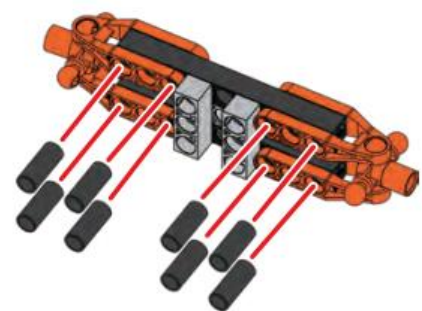

6

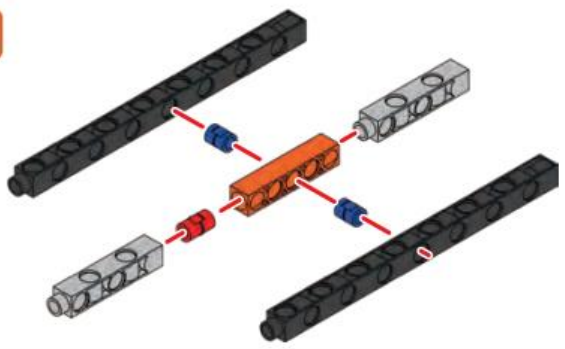

7

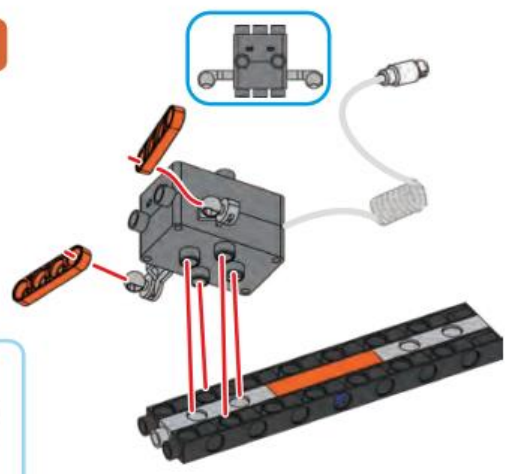

8

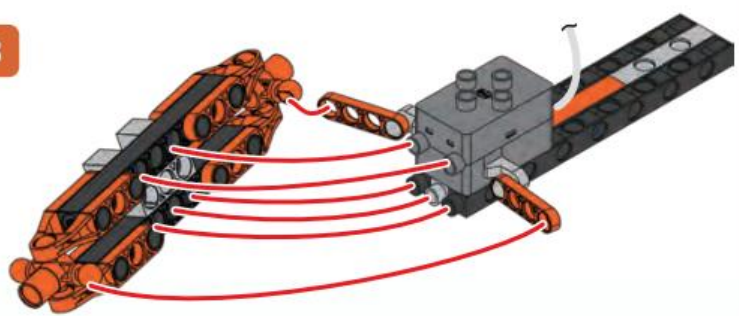

9 x4





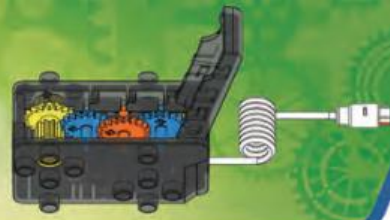

## SLEEK RACE CAR

### Model 1 Sleek Race Car

10

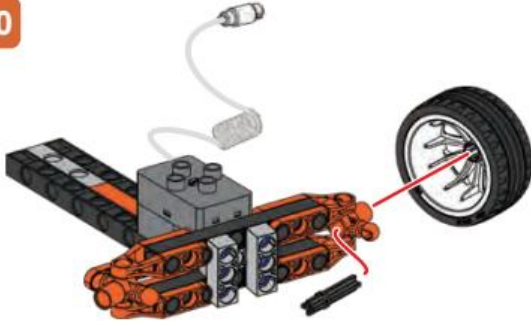

11

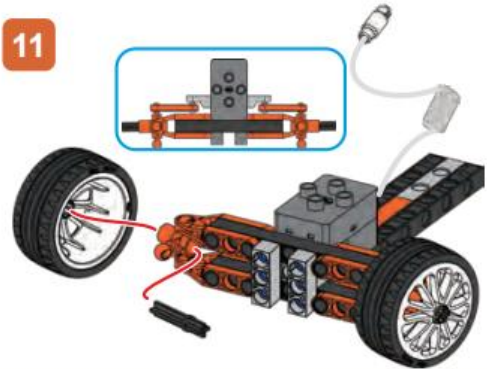

12



High Speed  
Low Torque

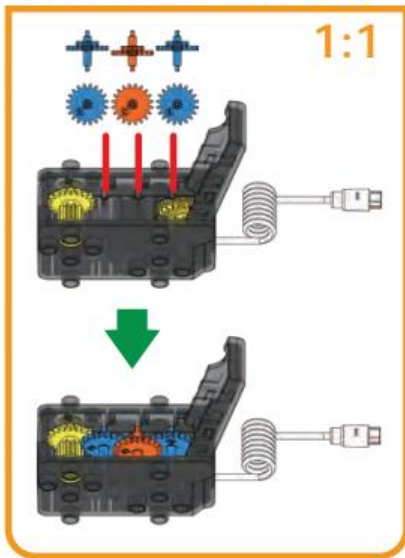

13

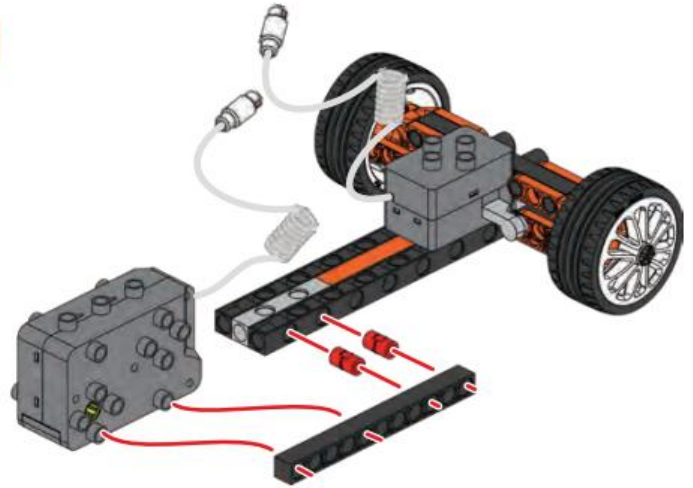

14

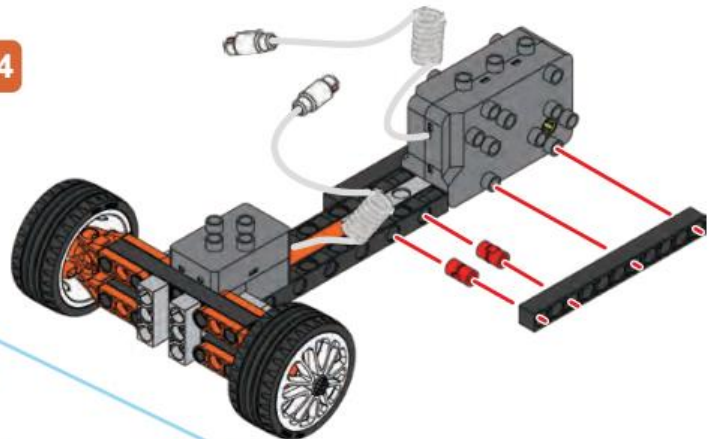

15

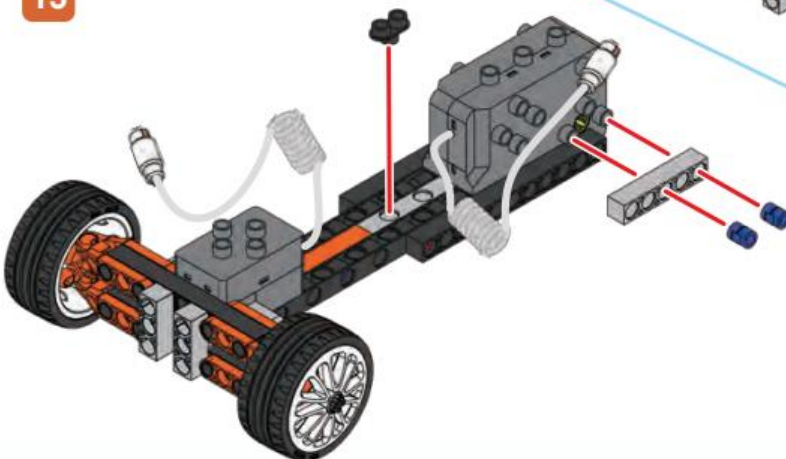





## Sleek Race Car Model 1

16

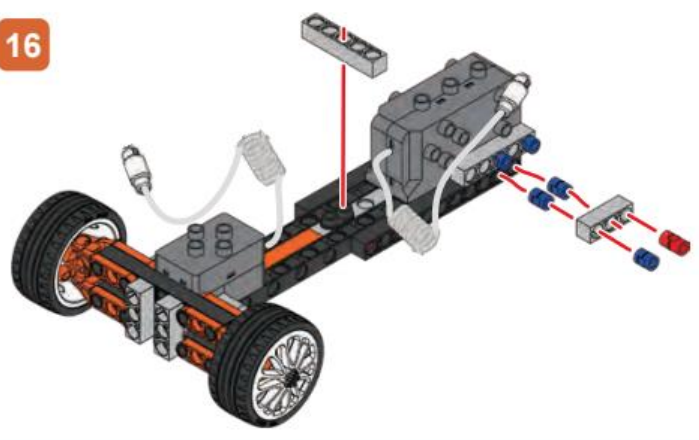

17 x2

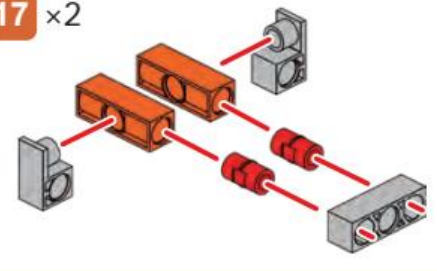

18

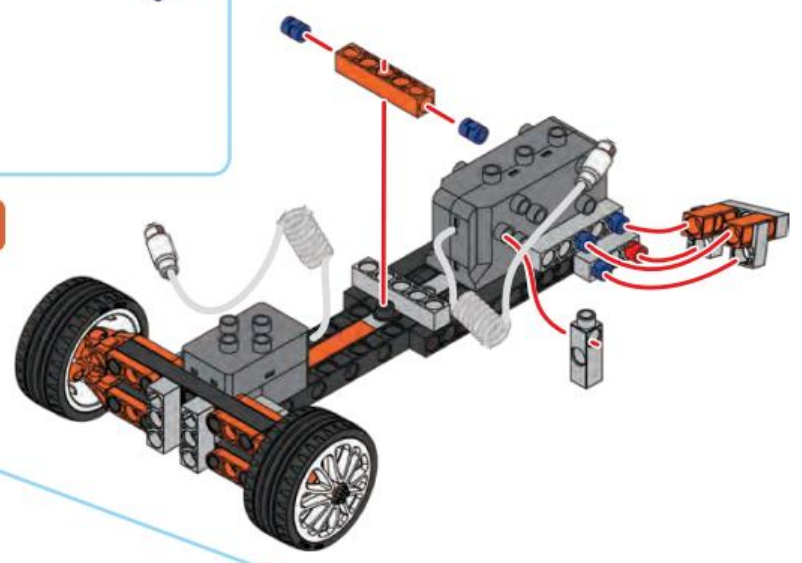

19

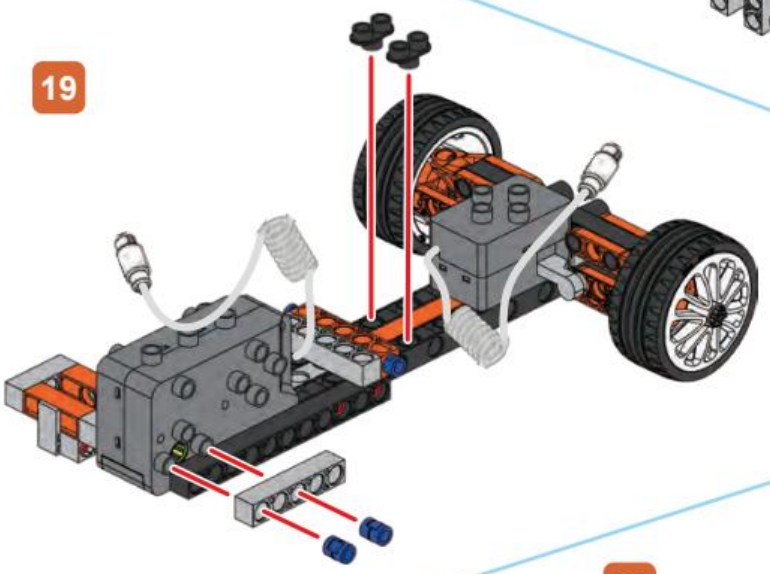

20

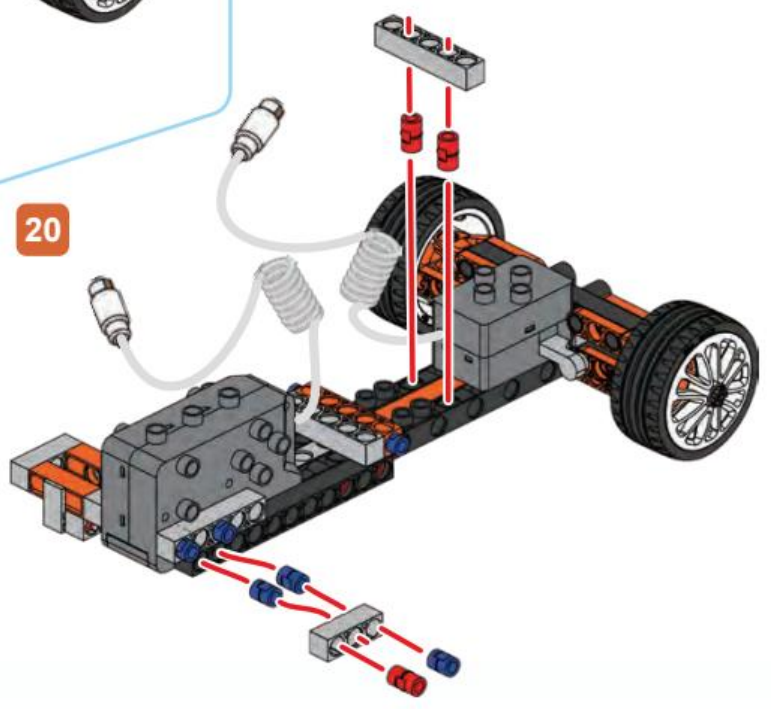





● ● ● SLEEK RACE CAR

Model 1 Sleek Race Car

21

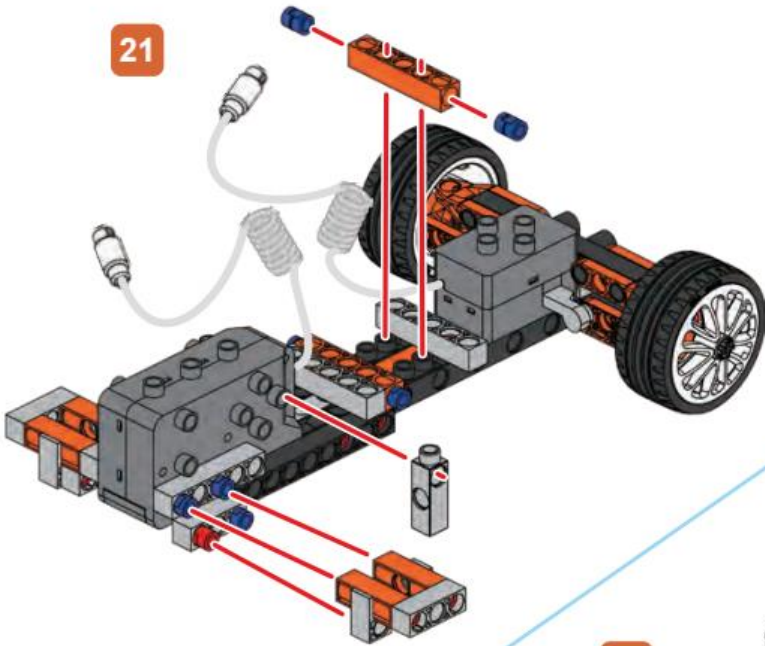

22

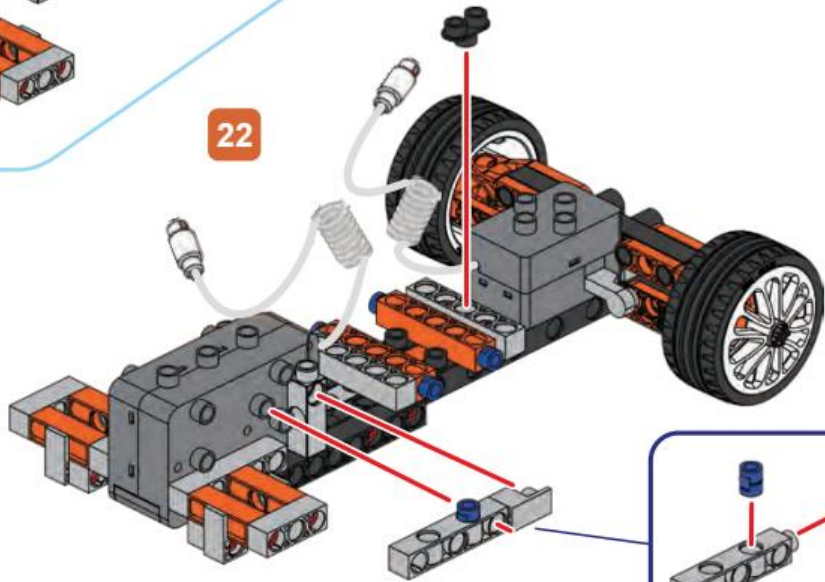

23

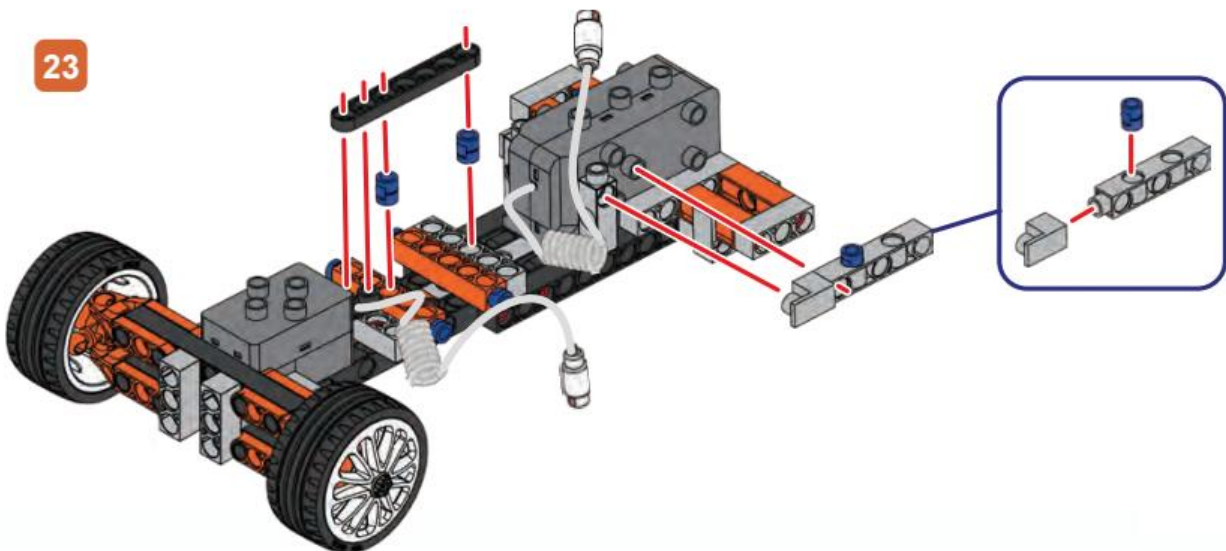





## Sleek Race Car Model 1

24

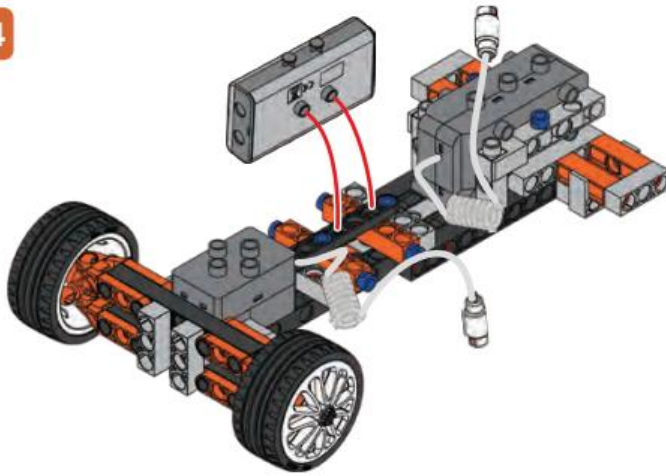

25

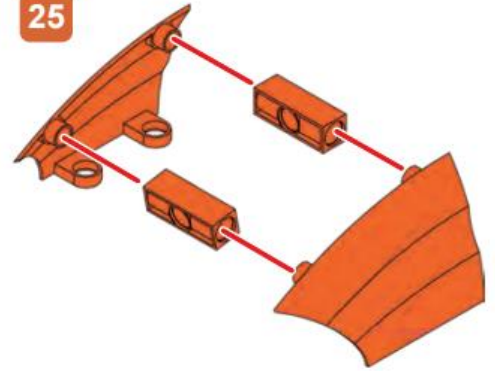

26

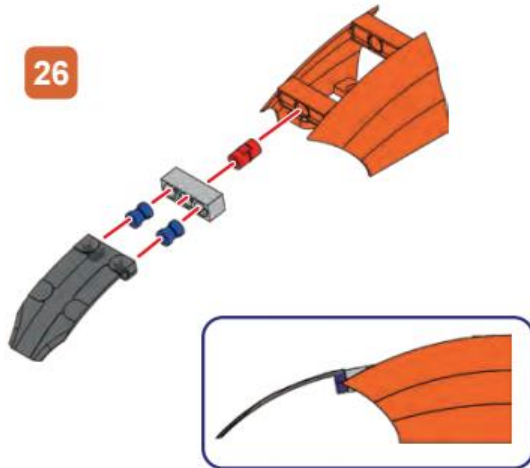

27

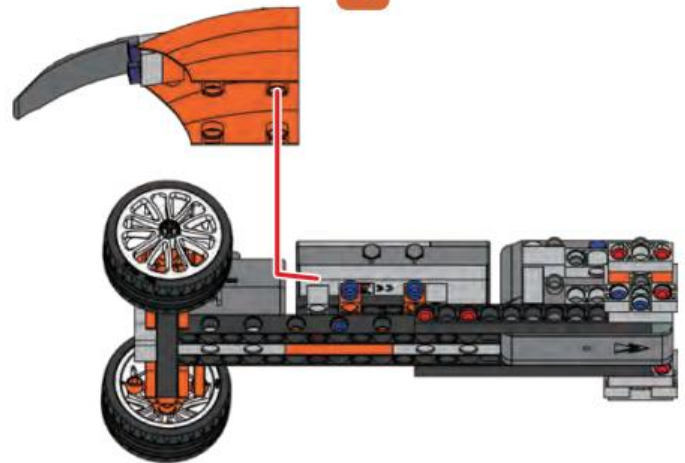

28

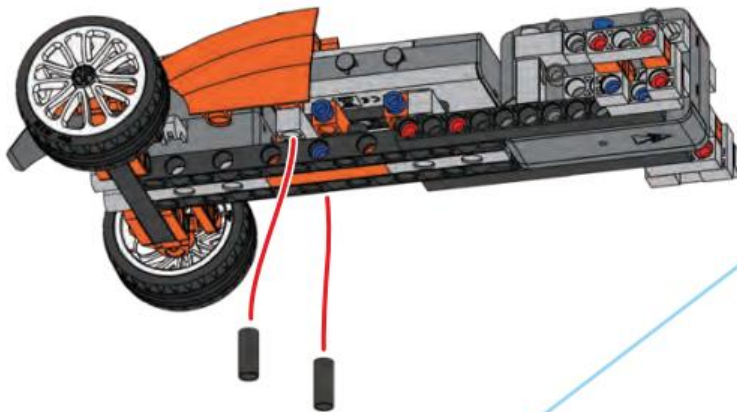

29

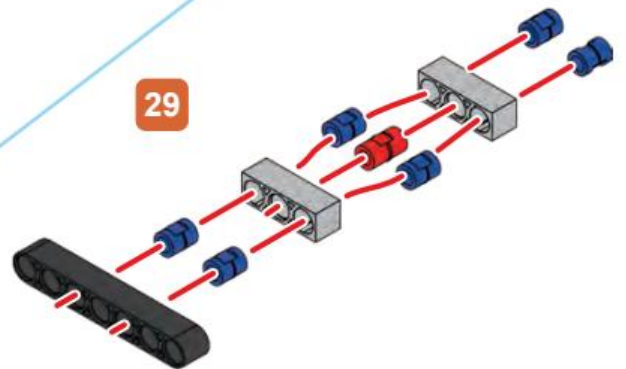



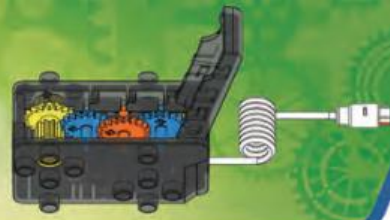

## ● ● ● SLEEK RACE CAR

### Model 1 Sleek Race Car

30

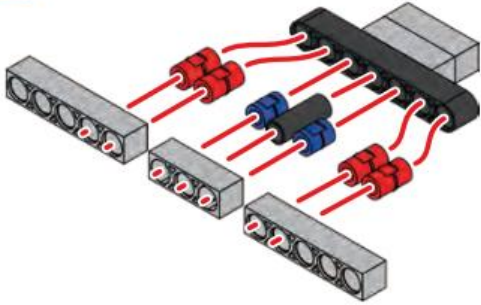

31

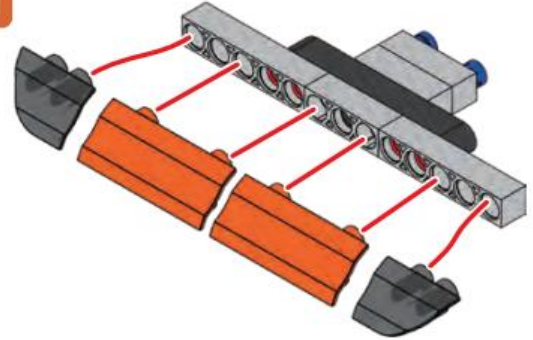

32

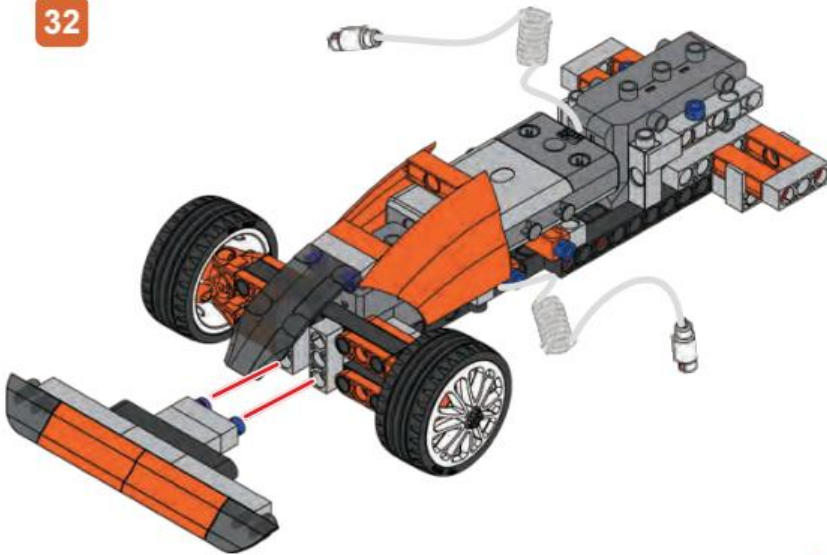

33

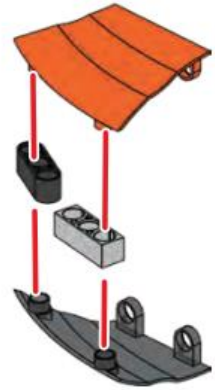

34

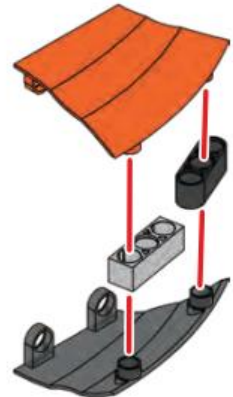

35

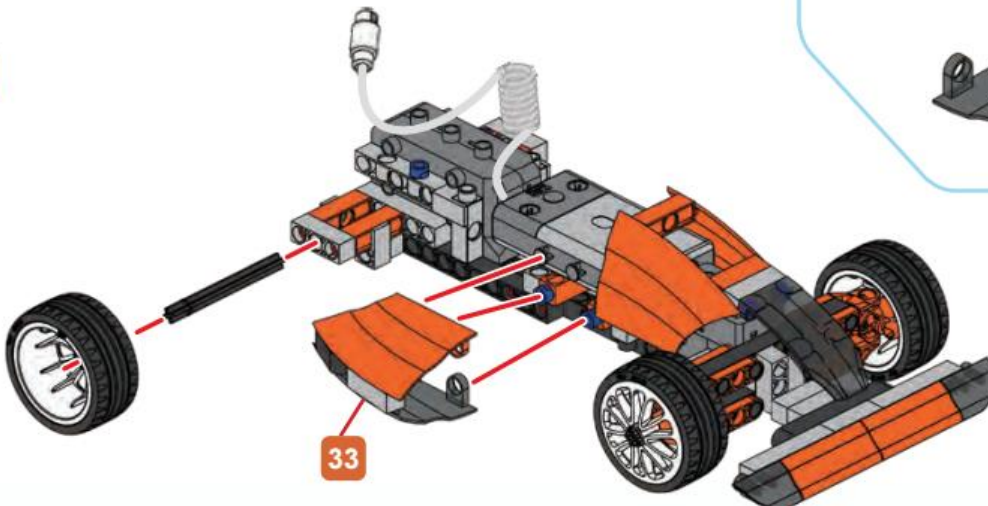





## Sleek Race Car Model 1

36

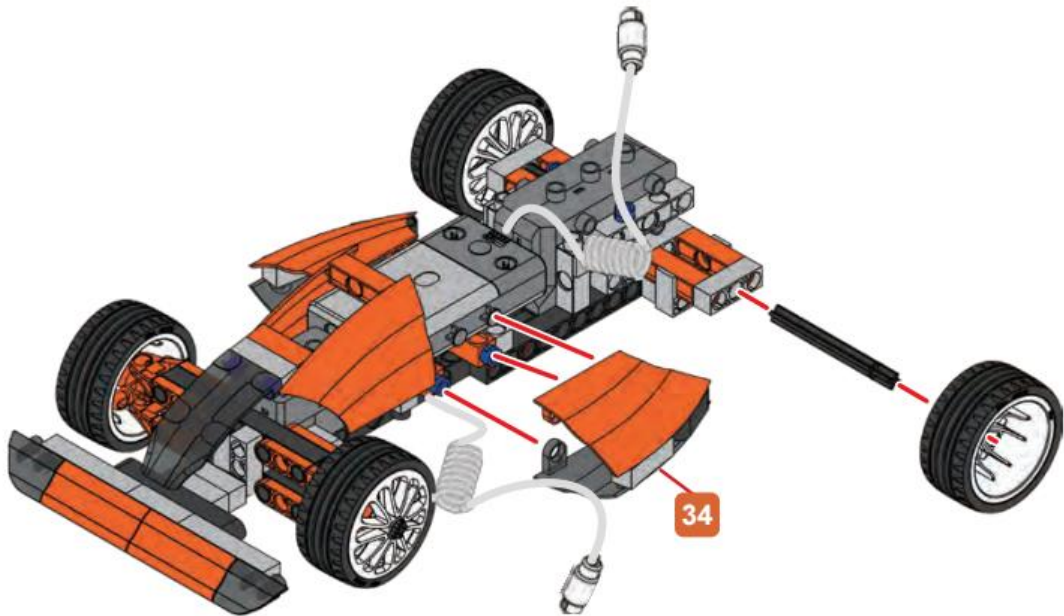

37

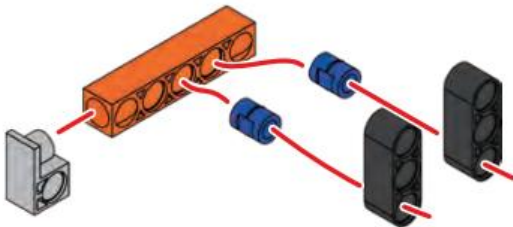

38

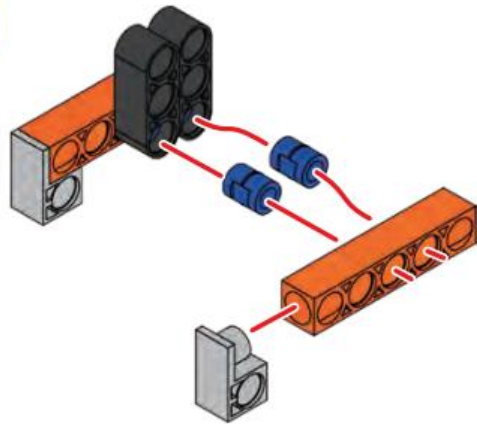

39

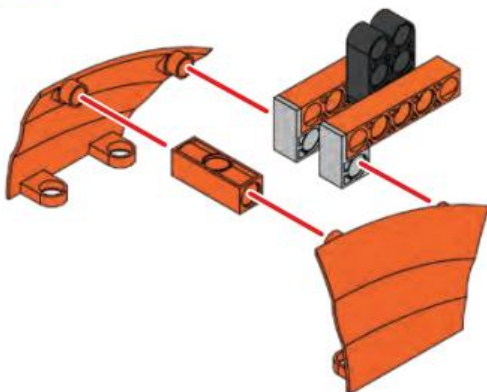

40

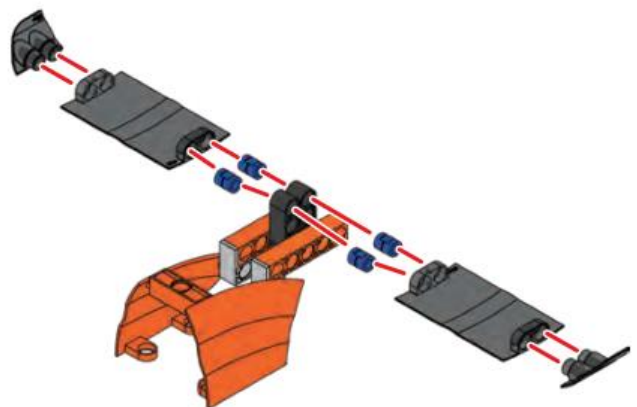





## SLEEK RACE CAR

### Model 1 Sleek Race Car

41

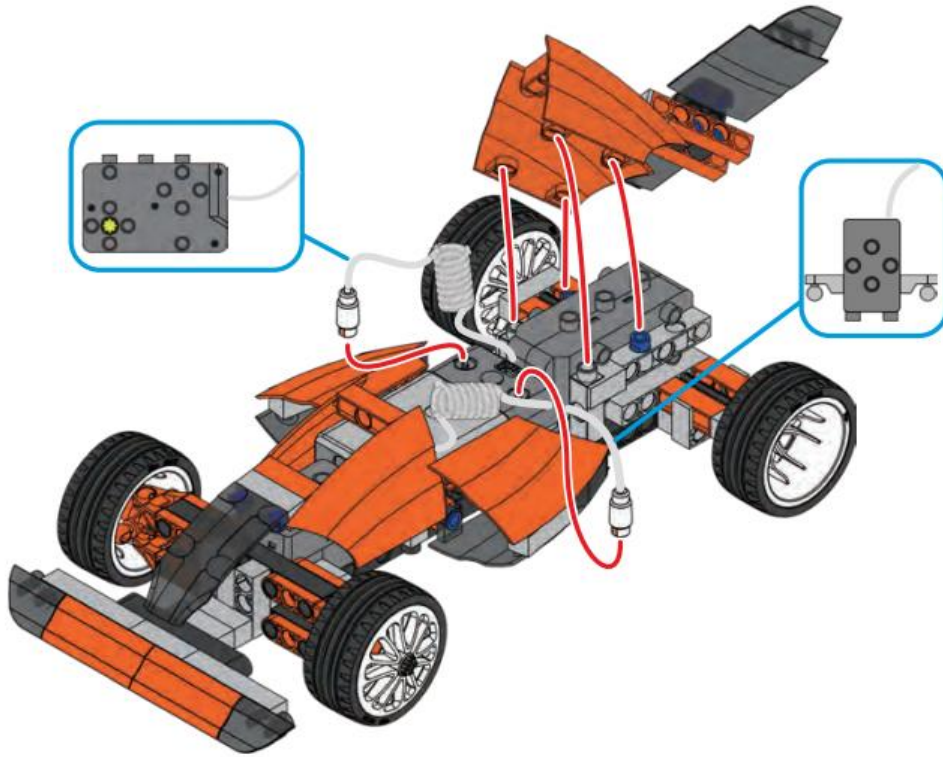

42

Stickers

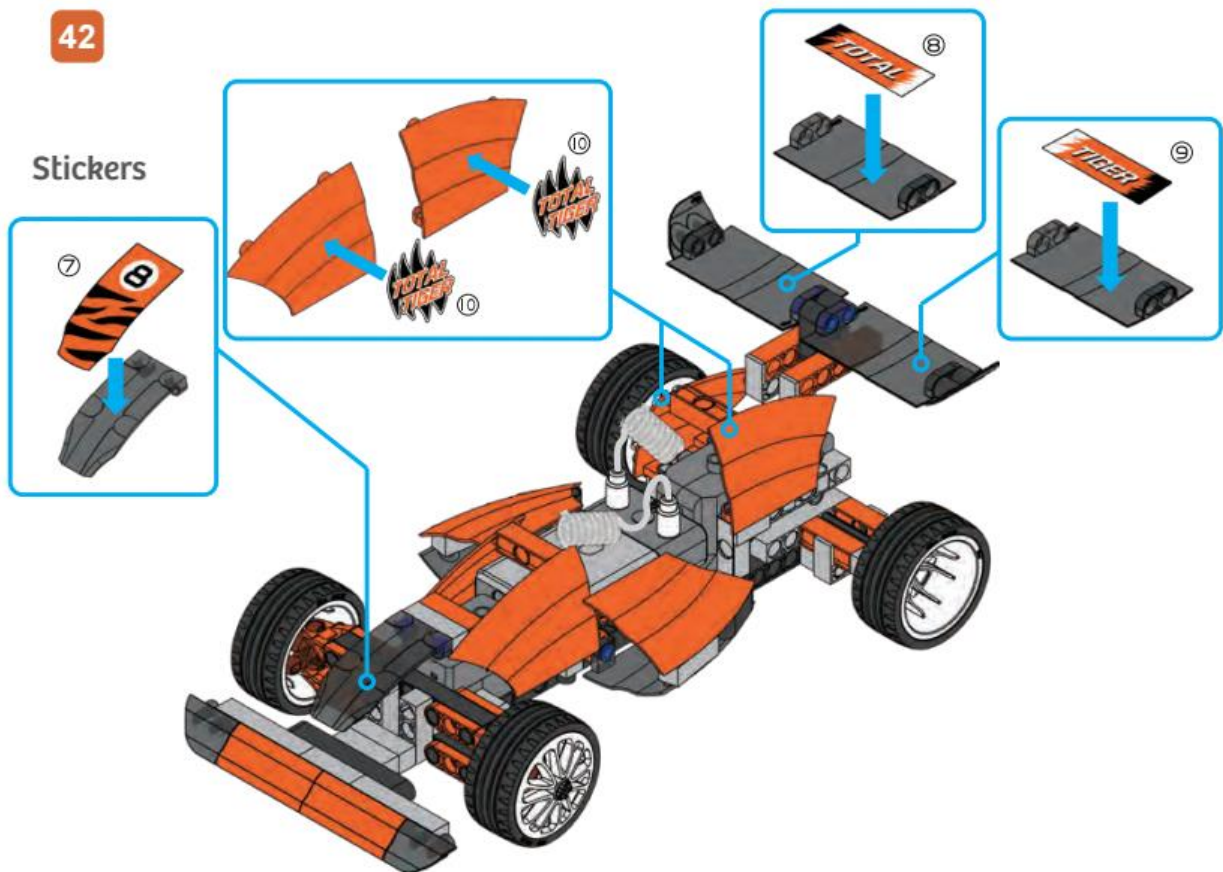





## Sleek Race Car Model 1

43

Done!



## EXPERIMENT 1

## Building a race track

## HERE'S HOW

Have a friend or family member set up a race course in a room in your house. He or she can gather various objects, such as small cardboard boxes (e.g., tea boxes and matchboxes), toys, and empty cans, and place them around the room. Set up a start and finish line. Turn on your model and race around the track as fast as you can! Take turns timing each other and see who can drive the model car around the track the fastest.







CHECK IT OUT



## The Physics of Cars

### ACCELERATION

**Acceleration** is a change in the velocity of an object. That means that the object could be speeding up, slowing down, or changing direction and it would be accelerating. The time it takes for a car to go from 0 to 60 miles per hour is a common measure of a car's ability to accelerate.



### FORCE

When a car turns a corner sharply, accelerates, or decelerates, you feel a push or a pull on your body. This is because the car is exerting a **force** on you. A force is necessary to make an object move and is proportional to the amount of mass and the acceleration of an object. It is very important for the engineers who design cars to understand the forces that a car experiences when in motion. Based on your experiences, what forces do you think act on a car when it is moving?

### WORK

The way that physicists define work is different than the common usage of the word. **Work** is when a force causes a displacement in the same direction as the motion of an object. For example, if you were walking around at a steady velocity with a box in your arms you would *not* be performing work. This is because the force required to hold up the box points in the upward direction, while the displacement from your walking around is in the horizontal direction. However, if you were to push a box along the floor or lift a box up, you would be performing work.





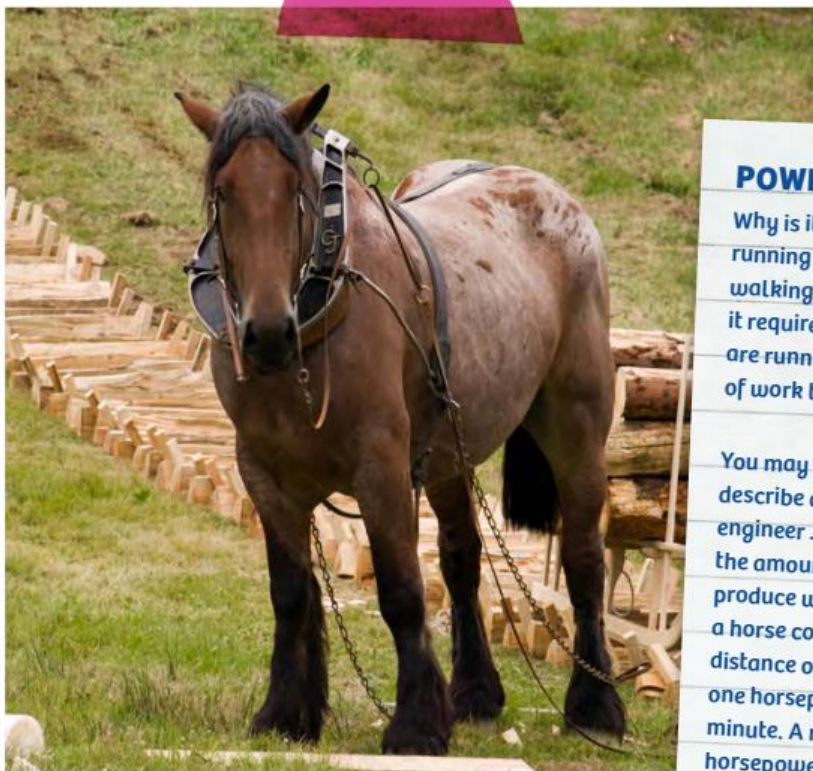

## POWER

Why is it harder to carry a heavy box while you are running up a flight of stairs than it is while you are walking up the same flight of stairs? It is because it requires more power to move the box when you are running. **Power** in physics means the amount of work that is done over time.

You may have heard the term **horsepower** used to describe a car. In the late 1700s, the Scottish engineer James Watt wanted a way to compare the amount of power that a steam engine could produce with that of a draft horse. Watt found that a horse could lift about 33,000 pounds of coal a distance of one foot in one minute. Thus, Watt set one horsepower equal to 33,000 foot-pounds per minute. A normal person can produce about 0.1 horsepower, while a car can produce 120 or more horsepower.

## VELOCITY AND SPEED

**Speed** and **velocity** are often used interchangeably, but in physics they mean different things. **Speed** is just how fast something is going, while **velocity** is both how fast and in what direction. For example, if you are moving 30 miles per hour then that is your speed. But, if you are moving 30 miles per hour north then that is your velocity. The speed of a car is given by the speedometer in miles per hour or kilometers per hour.



## TORQUE

Another term that is often used to describe car engines is **torque**. **Torque** is a measure of how hard you twist something, such as when you are turning a wrench. When torque is used to describe a car, it is referring to how hard the engine can turn the wheels. The torque of a car can be measured using a device known as a dynamometer.





### Parts Needed

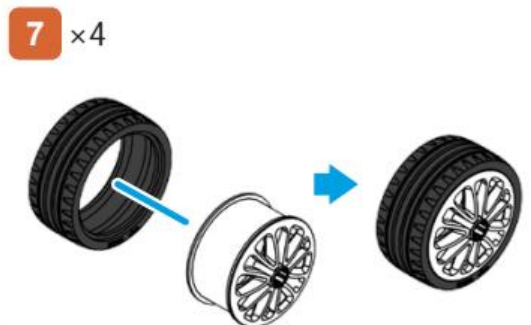
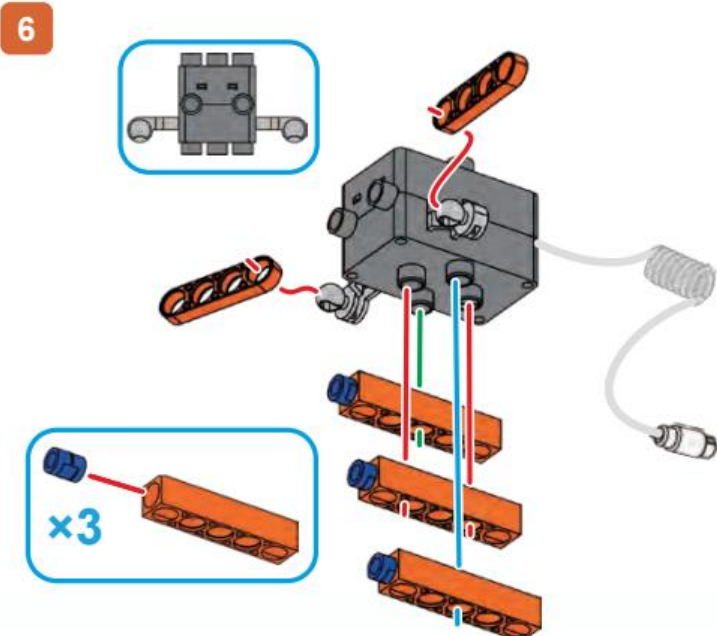
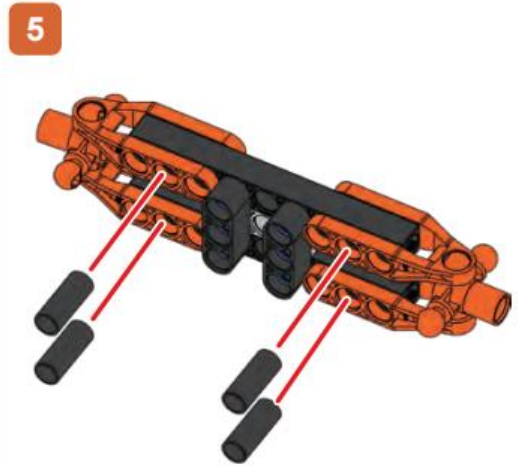
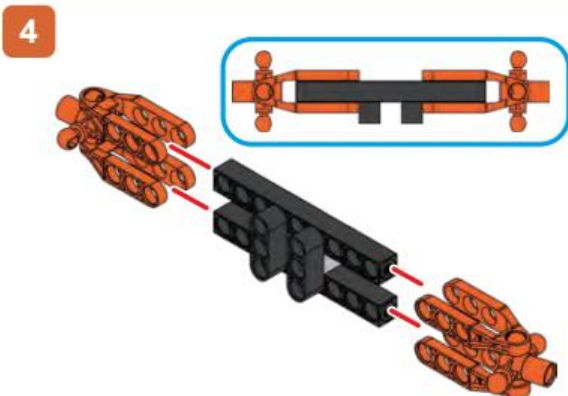
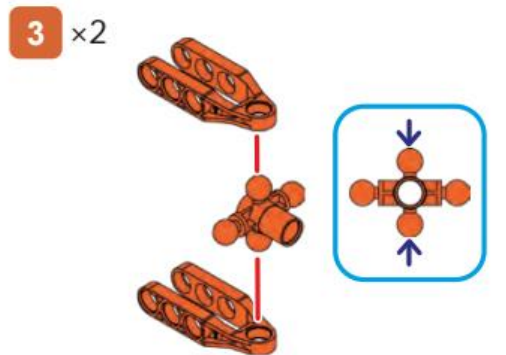
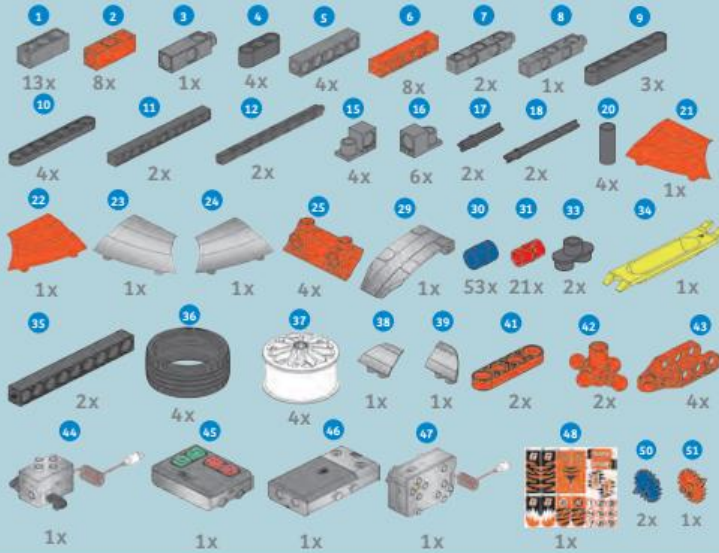



## Dragster Model 2

8

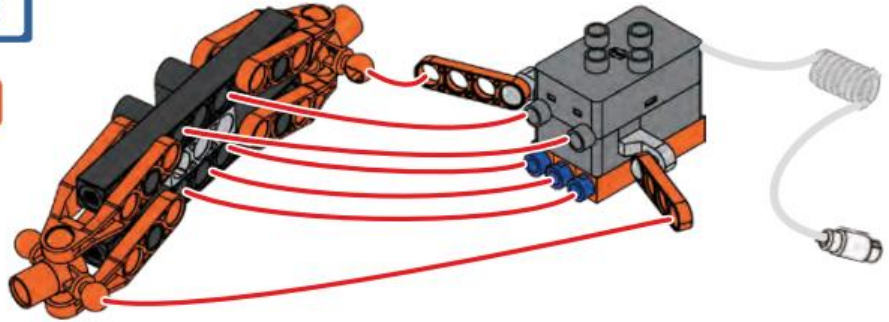

9

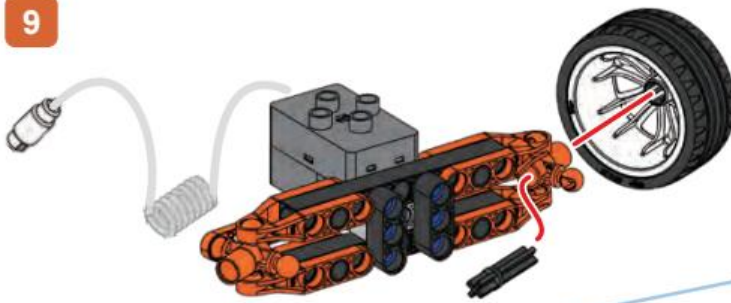

10

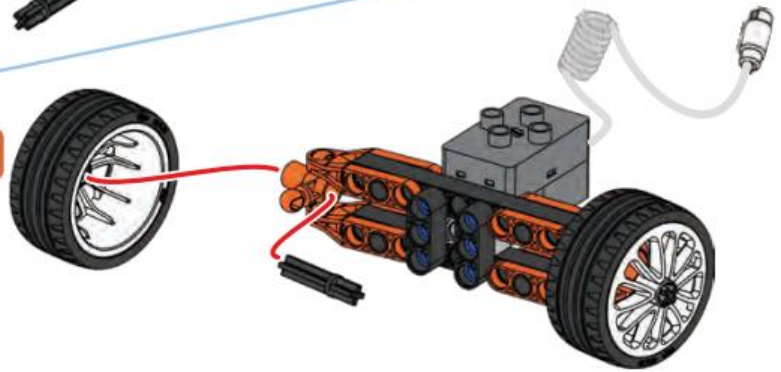

11

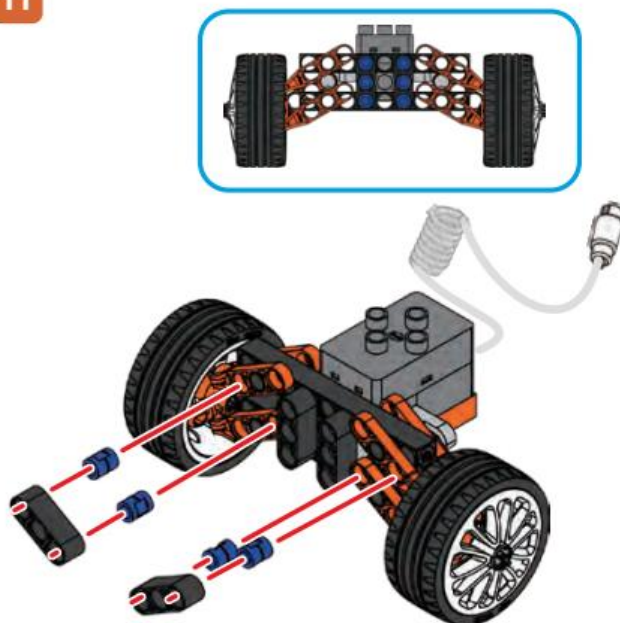

12

 **High Speed**  
**Low Torque**

1:1

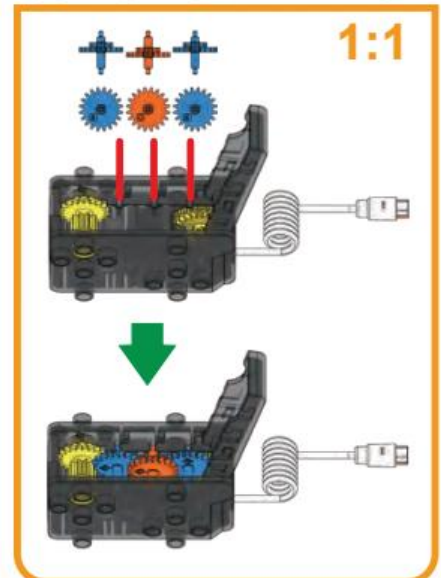



## DRAGSTER

## Model 2 Dragster

13

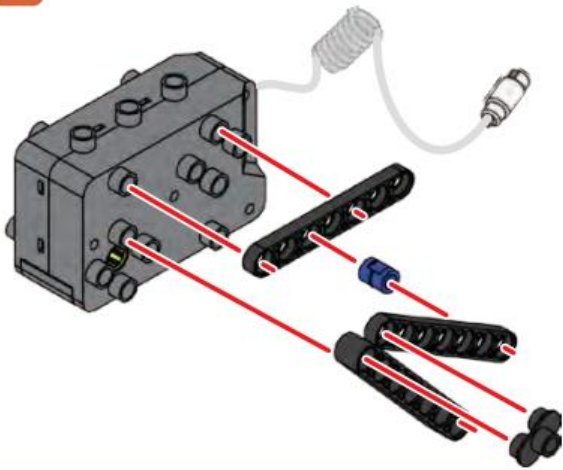

14

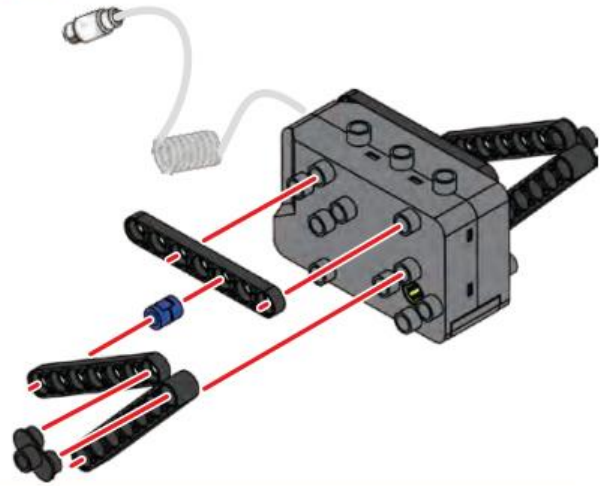

15

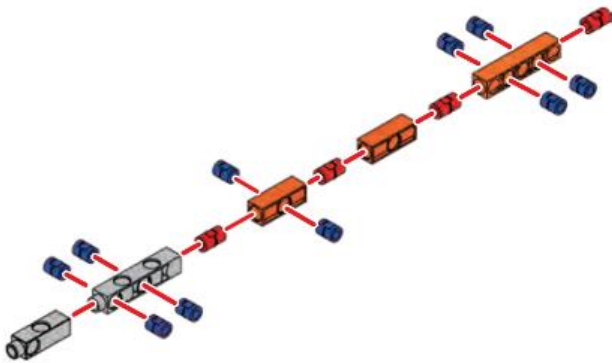

16

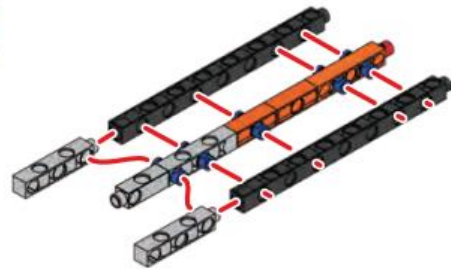

17



18

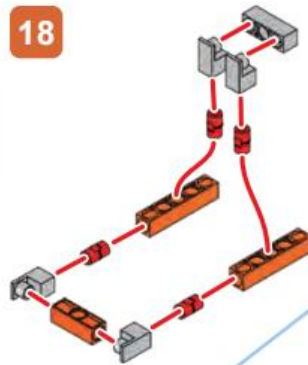

19

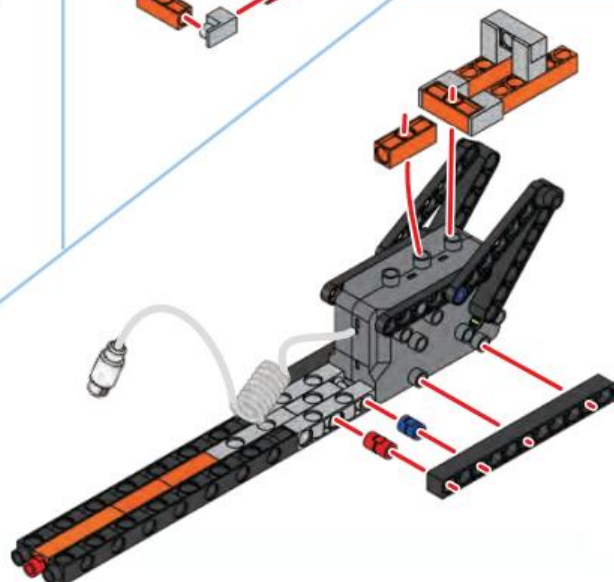





## Dragster Model 2

20 x2

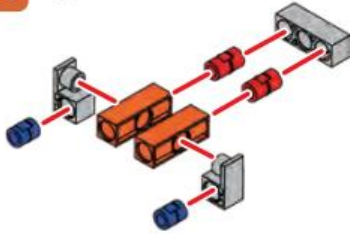

21 x2

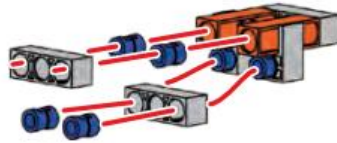

22

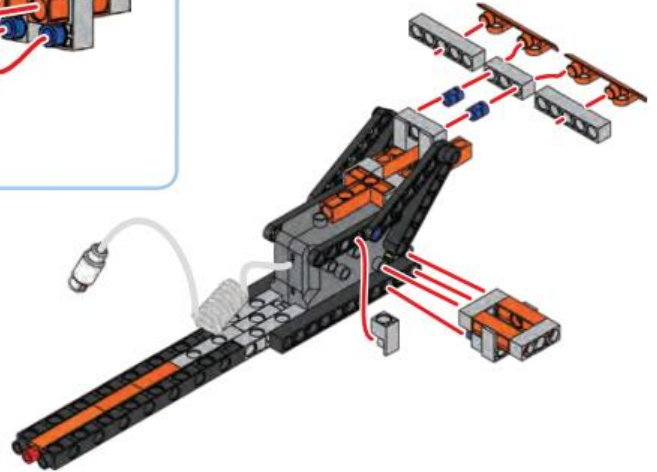

23

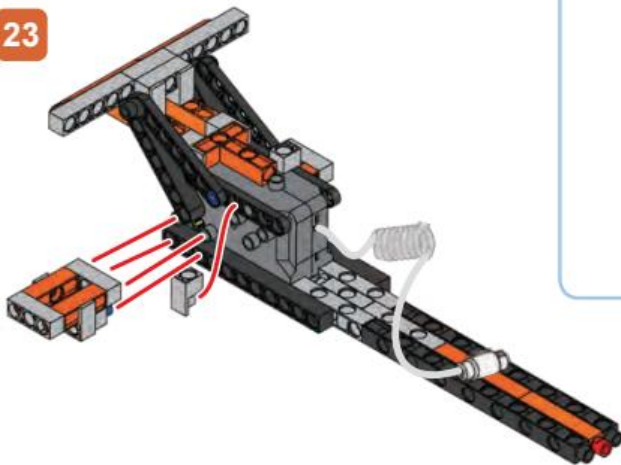

24

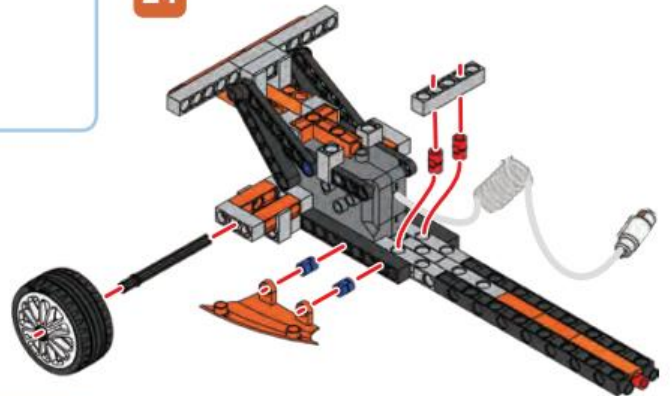

25

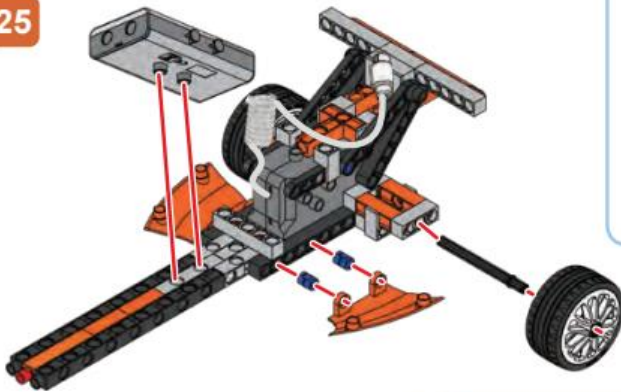

26



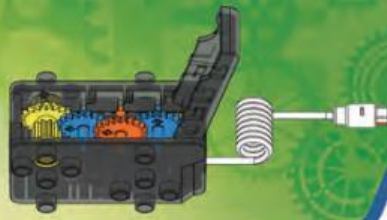

27

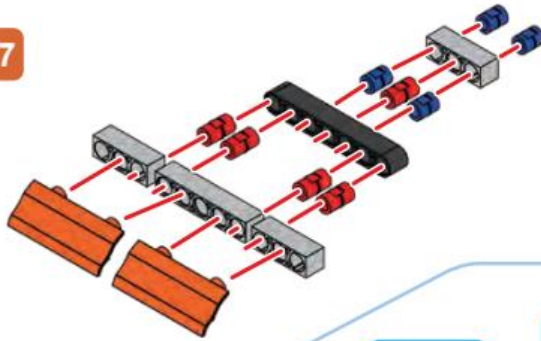

28

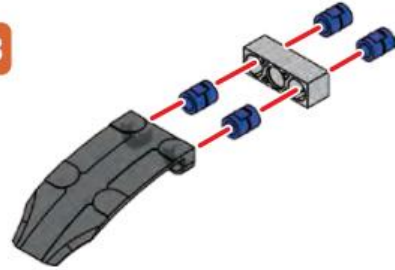

29

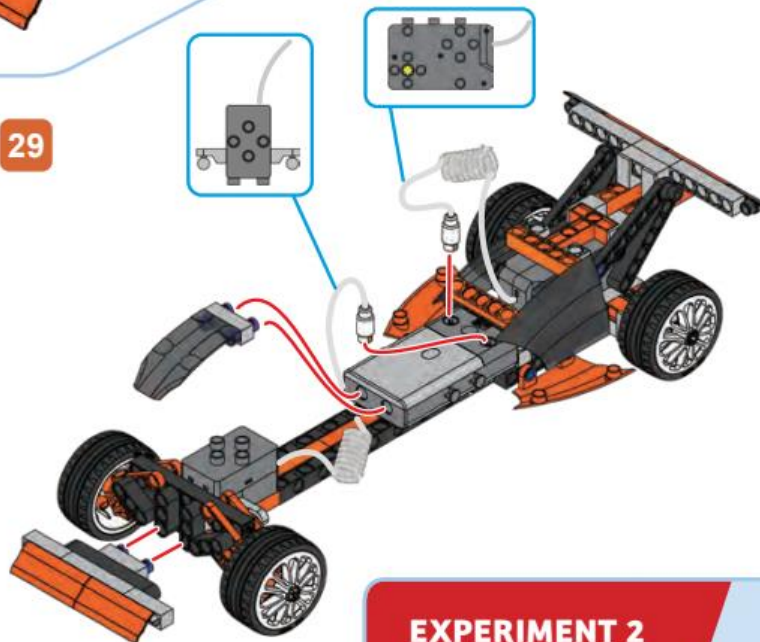

30



**Done!**

### EXPERIMENT 2

## Drag racing

### HERE'S HOW

Set up a long, straight track with start and finish lines for the dragster to race on. Have a friend or family member stand at the finish line with a stop watch. Turn the model on and place it at the start line. Have your friend or family member say out loud "3-2-1 Start." Immediately race the dragster down the track while your family member times you. Compete against your friends or family members and see who gets the fastest time. What would make the dragster go faster or slower down the track?





CHECK IT OUT



## CHRISTMAS TREE

Most drag races are started by an electronic system known as a **Christmas tree**. The Christmas tree consists of two columns of lights for each driver along with a set of lights on each lane. The Christmas tree also has sensors to know if the cars are lined up at the starting line.

## Drag Racing

Before each drag race, the driver is allowed to perform what is called a **burnout**. A burnout happens when a car is kept stationary while the wheels spin. Burnouts have an important function of heating up the tires making them stickier and putting a layer of rubber down at the starting line to improve traction. Burnouts have also become a form of competition and entertainment, with prizes going to cars that perform the best burnout.

## REACTION TIME

The cars start the race from a standing start, so an important part of drag racing is the driver's reaction time. The winner is determined by a combination of the driver's reaction time and elapsed time. After a race, because of the wear on the parts of a dragster, a lot of the parts will need to be replaced!

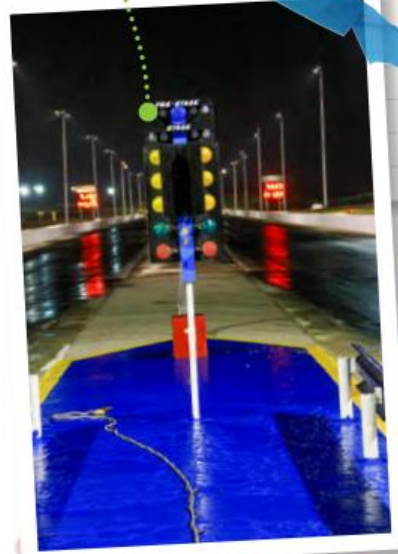

## ROCKET CARS

In 1984, Sammy Miller set the unofficial world record for the quarter mile in a rocket dragster named Vanishing Point. His time was 3.58 seconds. He had an average speed of 251 miles per hour. Rocket cars have been replaced by jet cars as the rocket propellant required to power these cars became too expensive. Rocket cars have been banned in most places due to safety concerns.



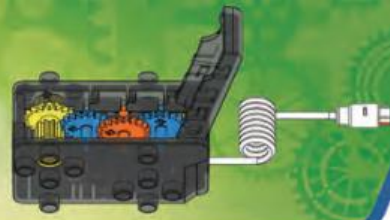

## SUPER CAR

## Model 3 Super Car

### Parts Needed

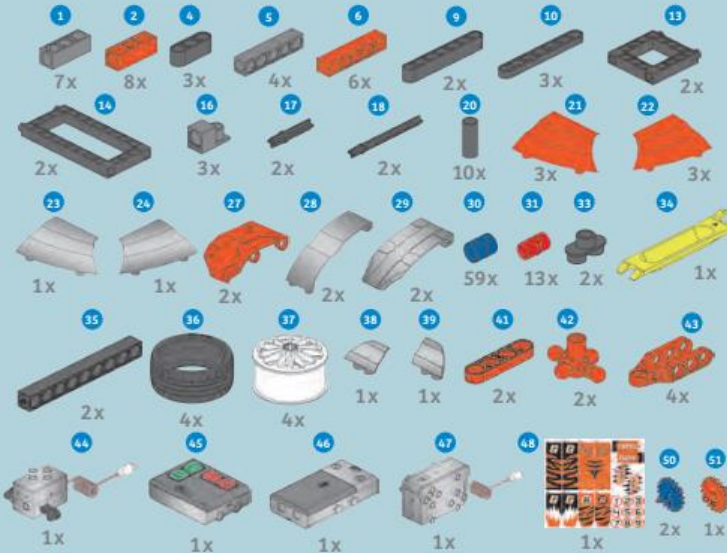

1 x2



2

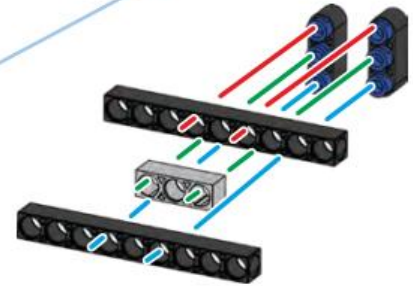

3 x2

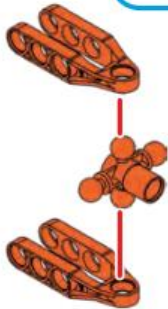

4

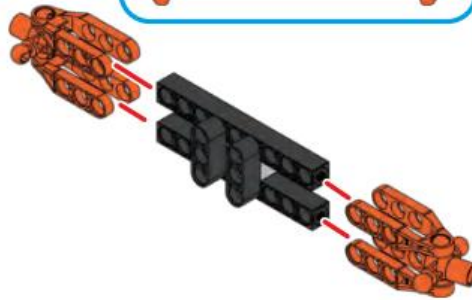

5

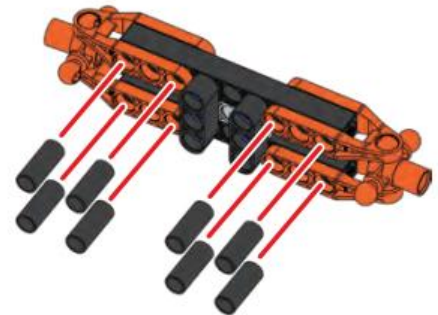

6

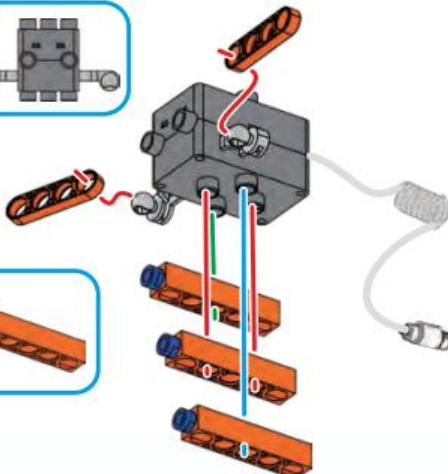
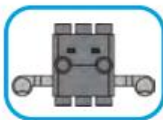

x3

7

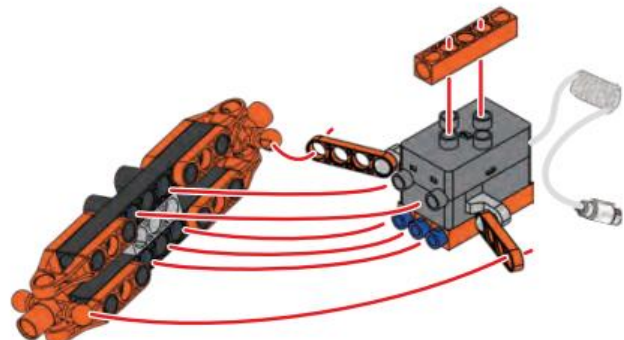





## Super Car Model 3

8 x4



9

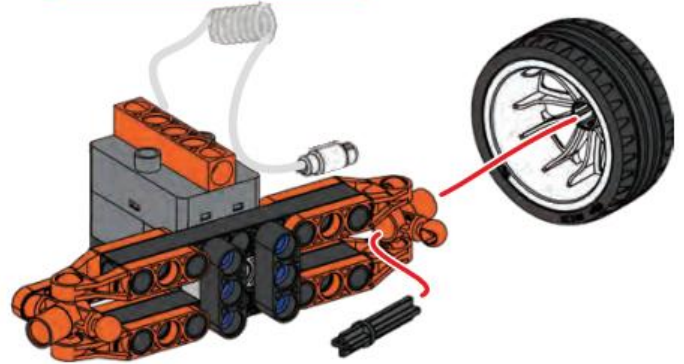
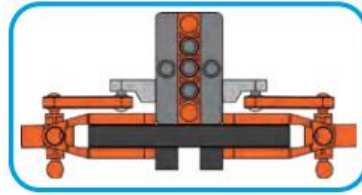

10

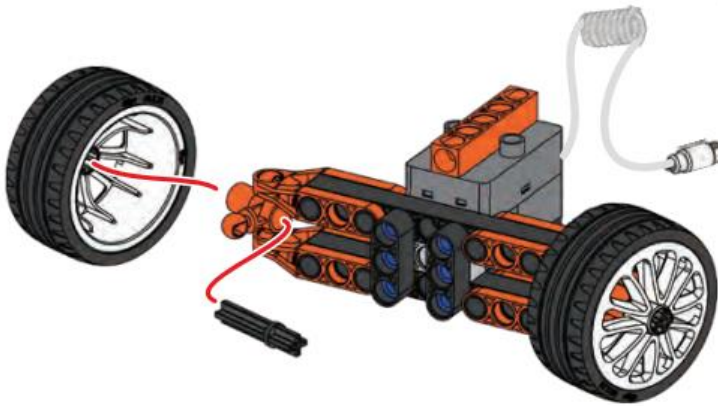

12



1:1

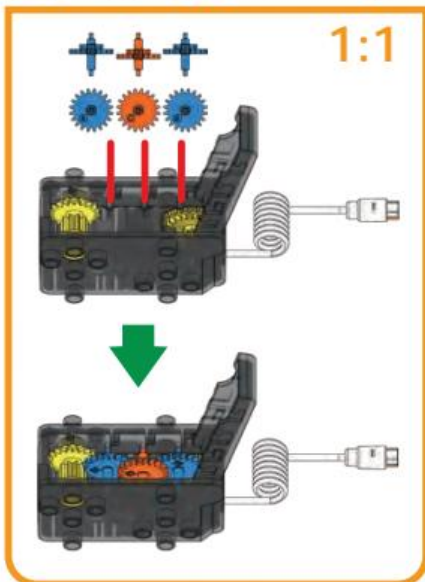

11

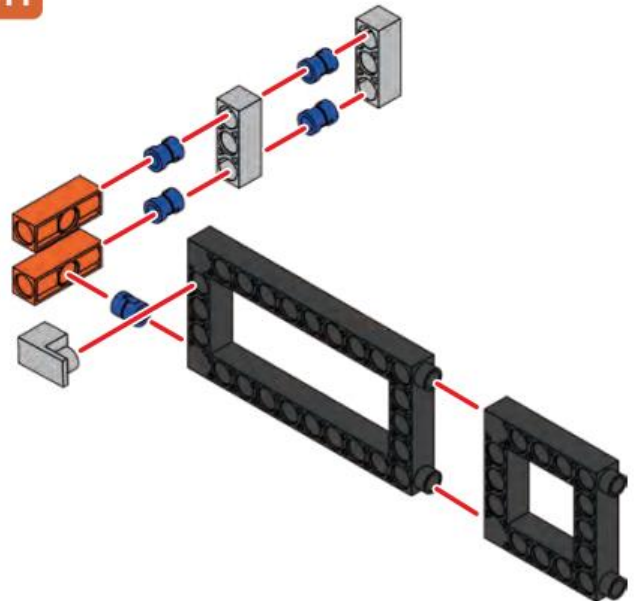





13

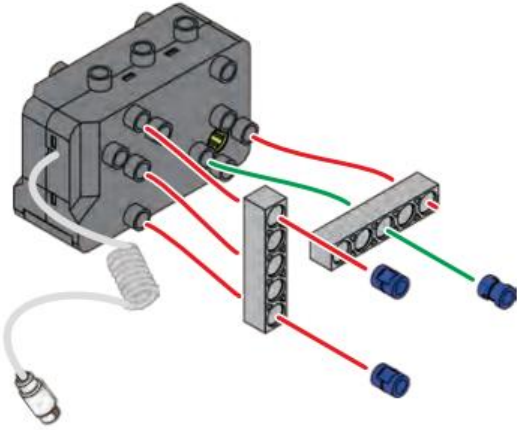

14

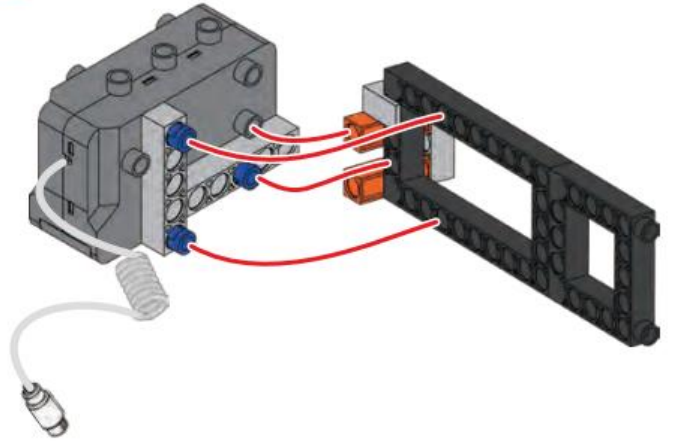

15

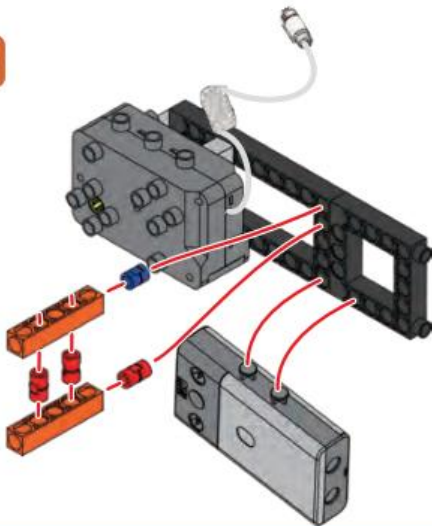

16

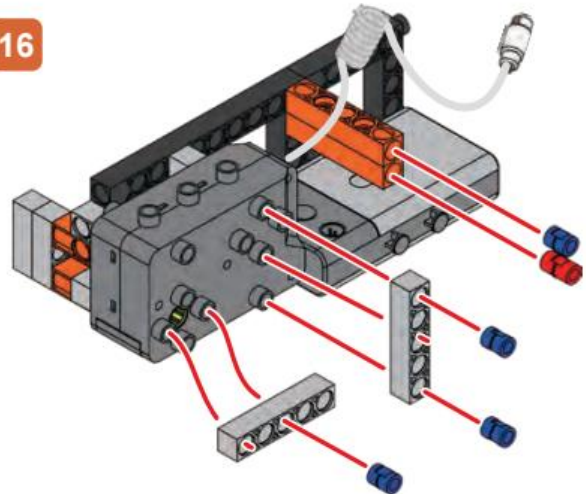

17

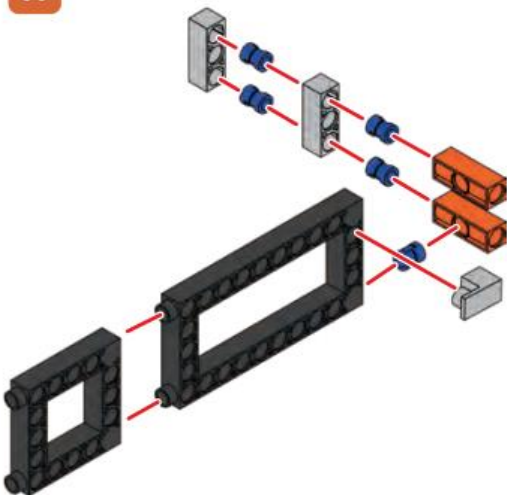

18

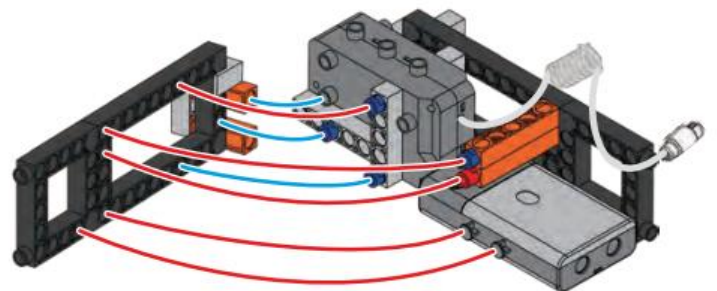



## Super Car Model 3

19

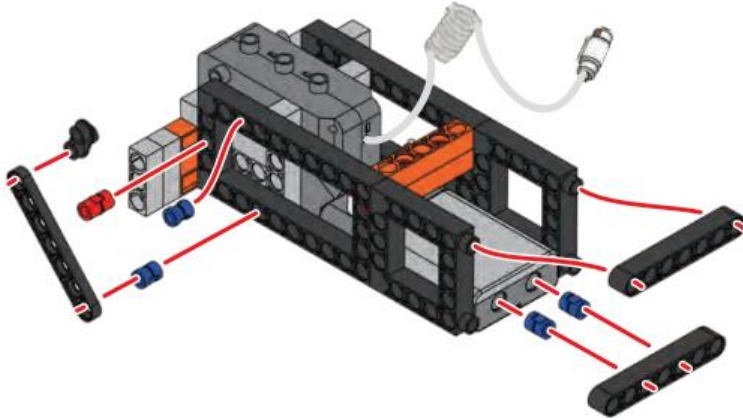

20

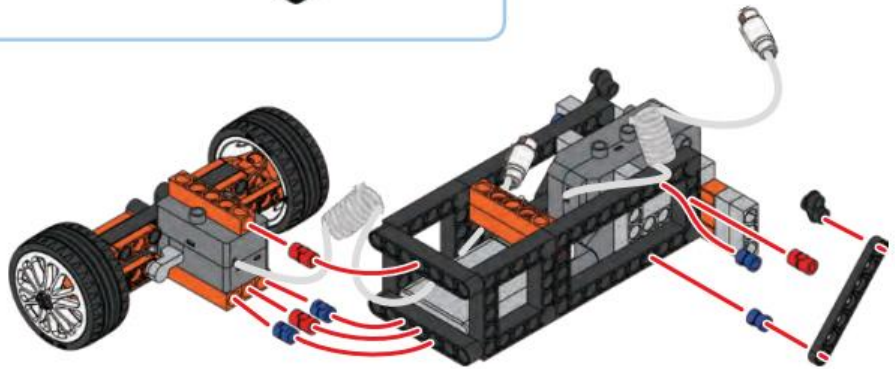

21



22







## ● ● ● SUPER CAR

## Model 3 Super Car

23

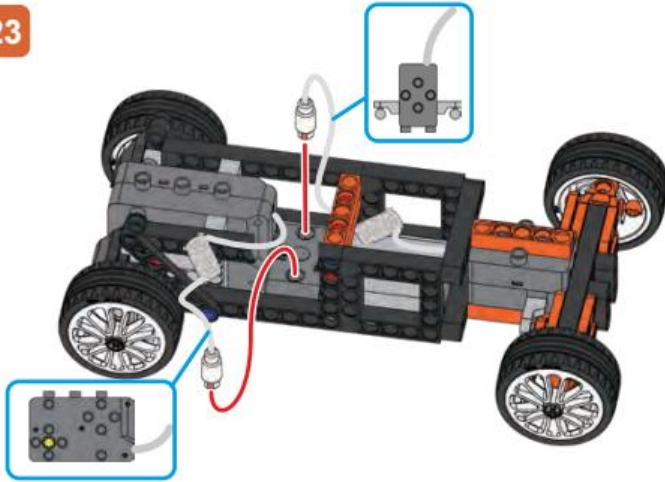

24

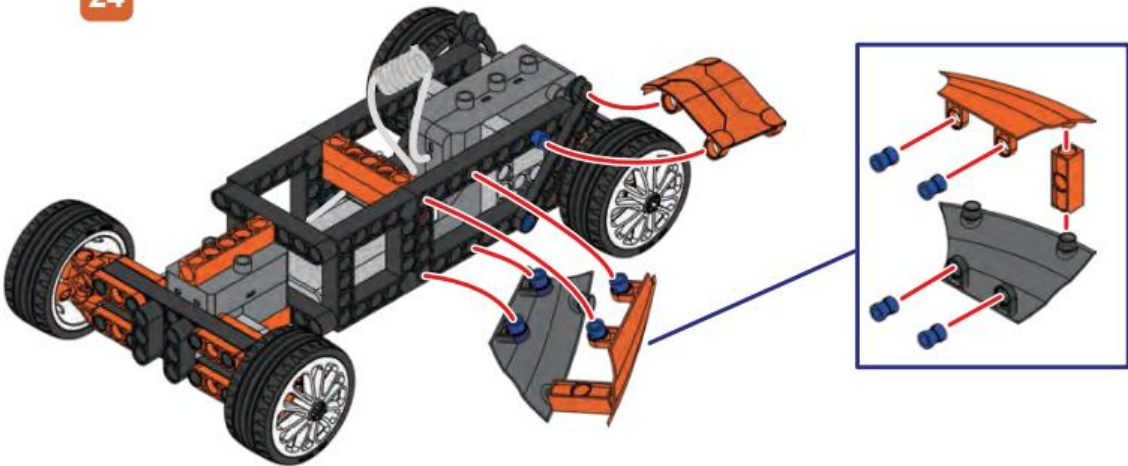

25

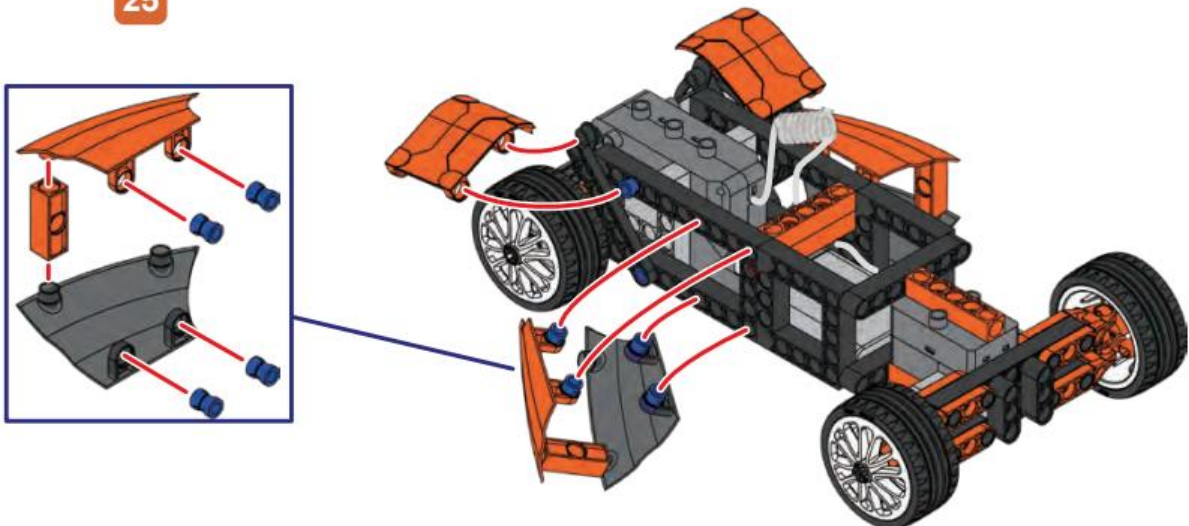



## Super Car Model 3

26

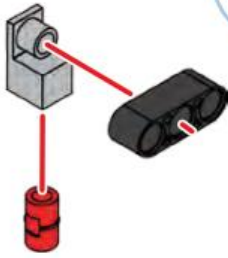

27

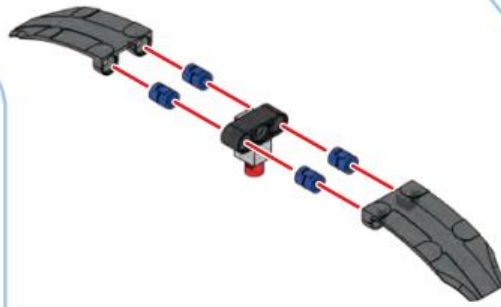

28 x2

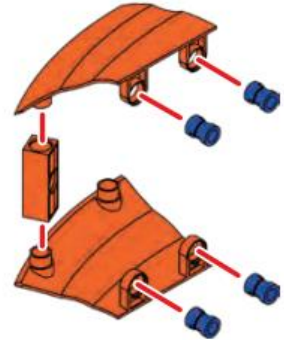

29

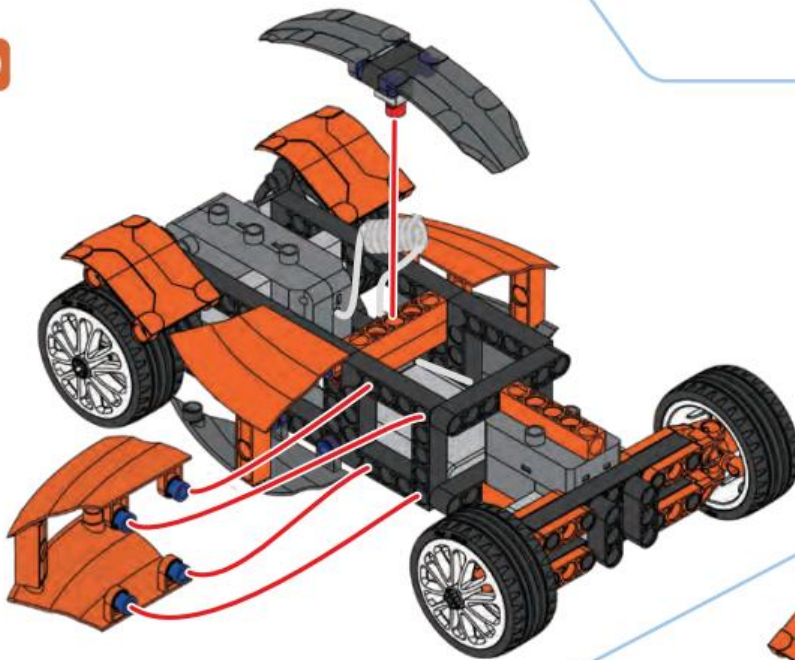

30

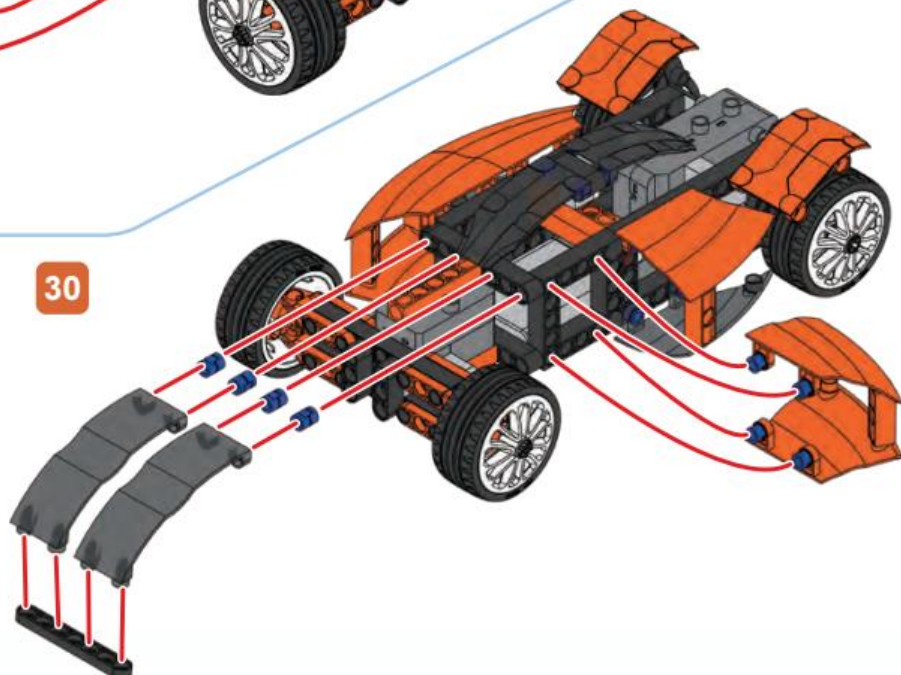



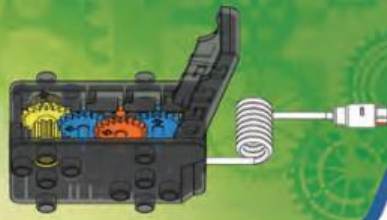

### Stickers

31

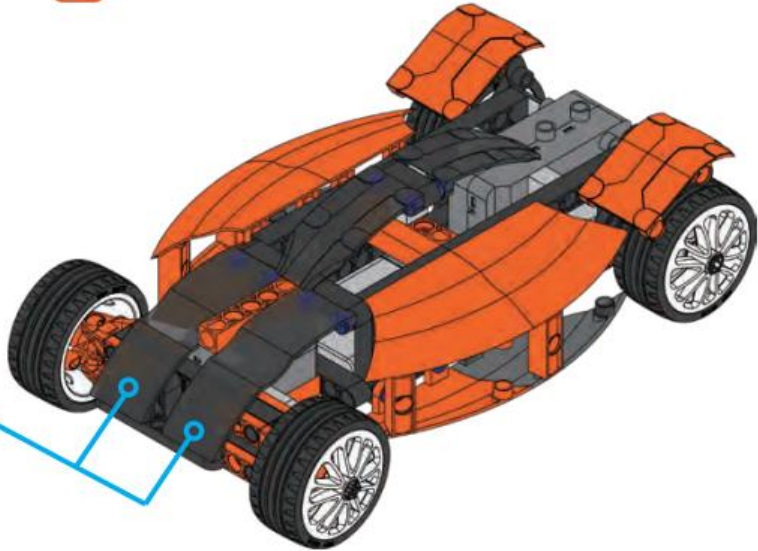
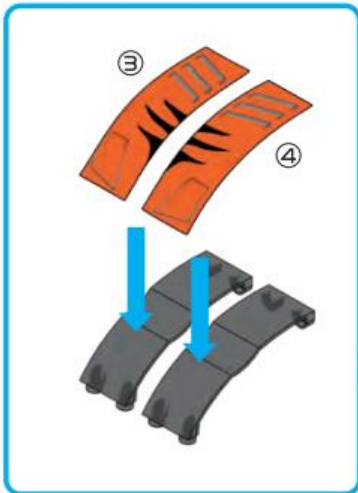

32

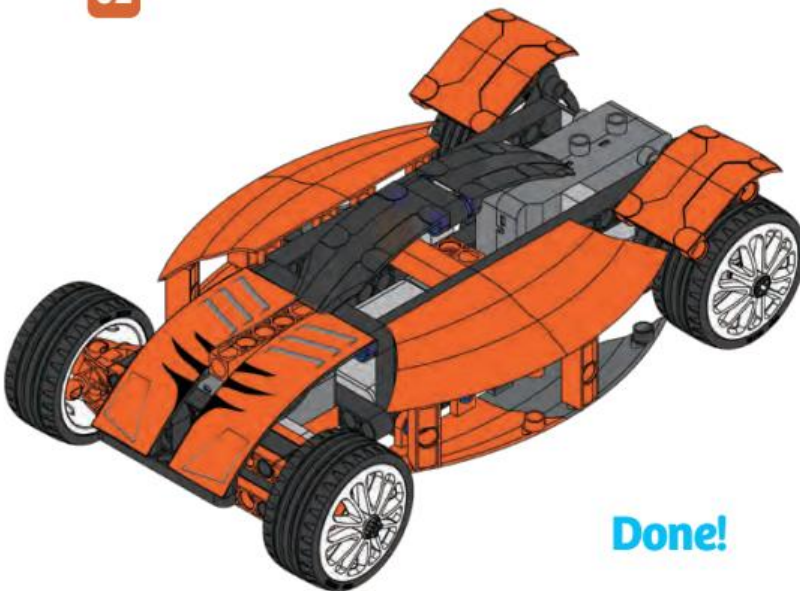

Done!

### EXPERIMENT 3

## Investigating Friction

### HERE'S HOW

Set up two straight tracks that are 5 feet long. One should be on a smooth surface, like a wood or laminate floor. The second should be on a rough surface, like a carpet. Turn on the super car model and race it down each track several times. Time how long it takes for the car to go down each track. How do the times compare?



CHECK IT OUT



## ENGINE

The **engine** in a car burns fuel (usually gasoline) to create heat, which is ultimately converted into mechanical motion and used to turn the wheels of the car. The fuel is ignited inside a **cylinder**, which has a **piston** inside that moves up and down. The piston is connected to a crankshaft. When the fuel ignites, the gas heats up and expands, pushing on the piston, which then turns the crankshaft.

You have probably heard a car being described as a "V6." It is called a "V6" because the cylinders are aligned in a "V" shape, while the "6" refers to the number of cylinders in the engine.

## FLYWHEEL

The crankshaft of the engine is connected to a **flywheel**. The flywheel is a large metal disk that is used to smooth out the rotation between the crankshaft and the driveshaft (the rod that turns the wheels).





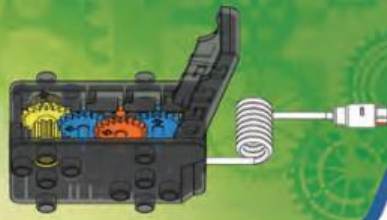

## CLUTCH

The **clutch** is used to separate the crankshaft of the engine from the drive shaft when the driver is changing gears. This allows for a controlled transmission of power while shifting gears — otherwise there may not be enough power to change gears or there may be too much power and the gears could be damaged. The clutch is essentially a disk that is normally pressed up against the flywheel, so that the crankshaft and drive shaft are rotating at the same speed. When the driver changes gears, the clutch and the flywheel separate, the transmission shifts gears, and then the clutch and flywheel come back together.

## TRANSMISSION

The **transmission** or gear train allows the driver to easily switch the car into several different gears. This is similar to how you change the gears in your custom car models, but the driver does not have to physically move the actual gears around inside the engine. The advantage of having a transmission is it gives a wide range of different gear ratios, which are useful in different situations. For example, when a car is going up a hill it is better to use a smaller gear and spin faster, so that there is less torque on the drive shaft. While on a flat surface it is better to use a larger gear and spin slower, providing more torque.





CHECK IT OUT

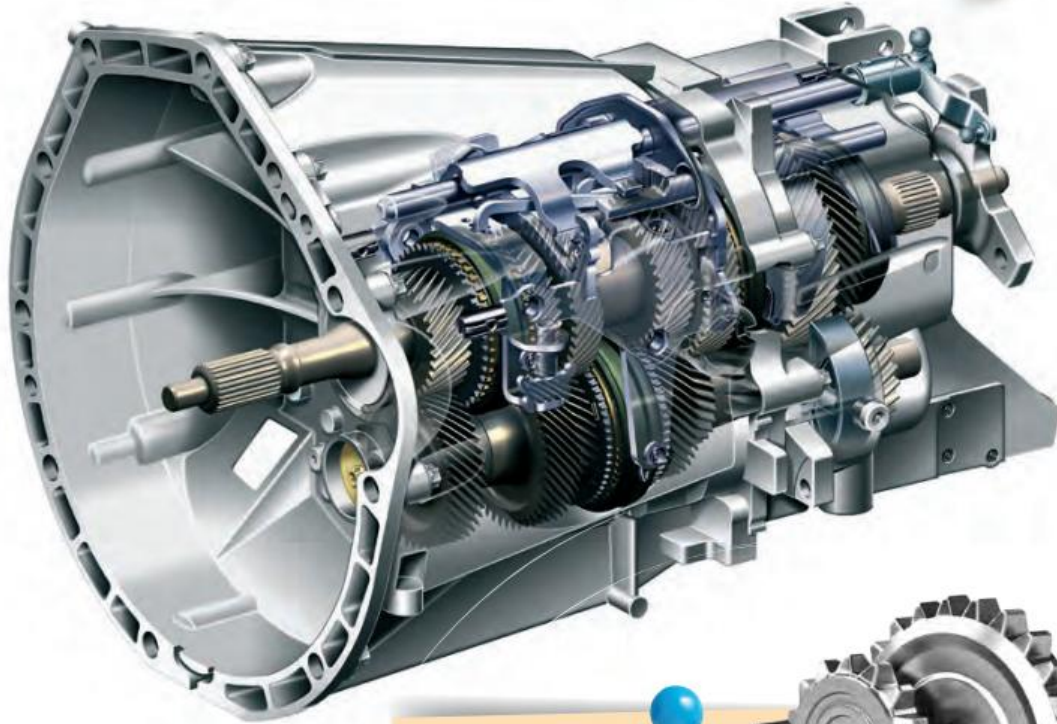

## GEARS

Gears are used in many different devices to transfer power. A gear is a rotating wheel that is connected to an axle and has teeth or cogs that are intermeshed with another set of teeth. Gears transfer power by changing the direction, speed, or torque of another gear.

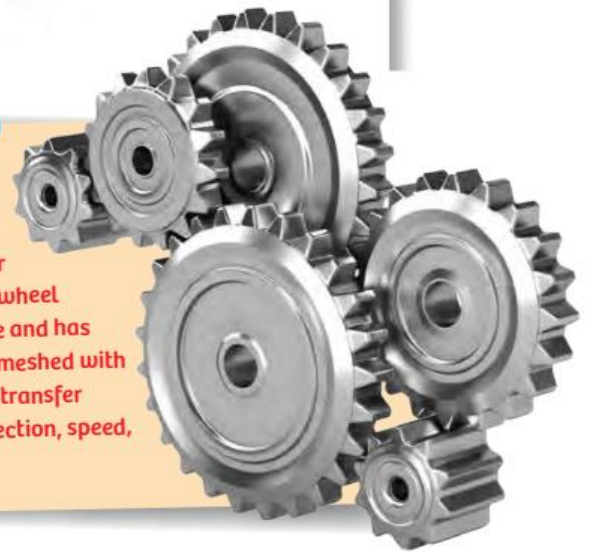

## DID YOU KNOW . . .

. . . that gears have been found in insects? In 2013, scientists from the University of Cambridge found gears in the rear legs of the juvenile form of an insect called *Issus coleoptratus*. The gears make it so that the insect's legs are synchronized when it jumps. If the legs were not synchronized the *Issus* would spin out of control every time it tried to jump. This gear mechanism also gives the insect more power when it jumps.

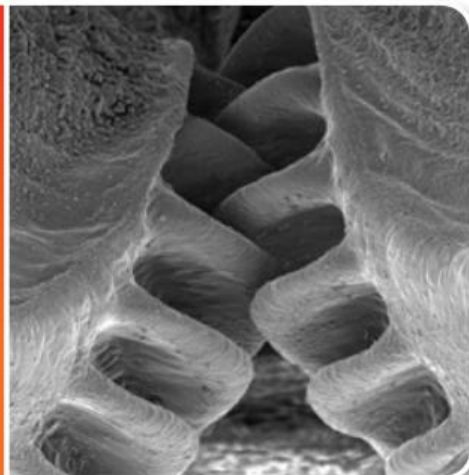



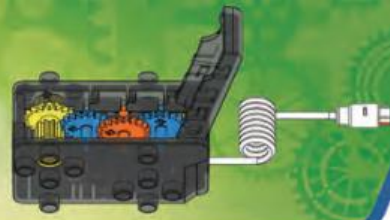

**HOT ROD**

## Model 4 Hot Rod

### Parts Needed

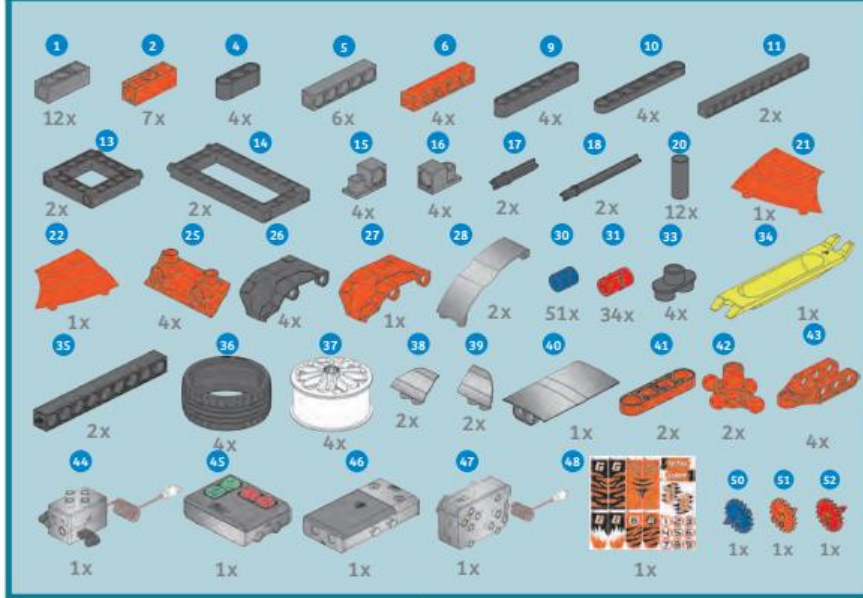

**1** x2



**2**



**3** x2

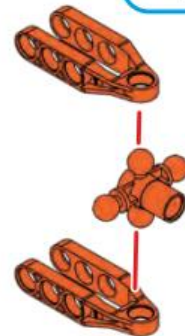
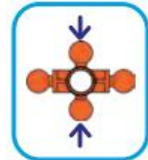

**4**

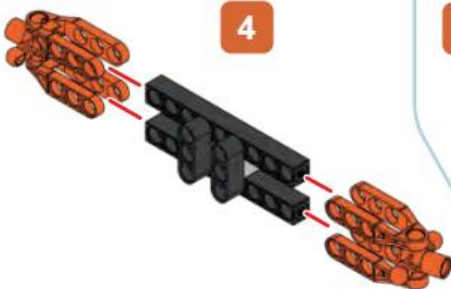

**5**

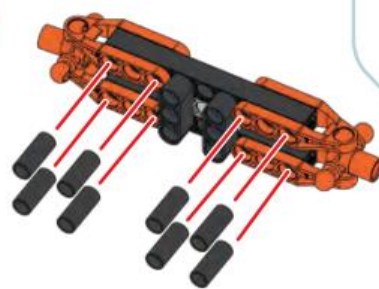

**6**

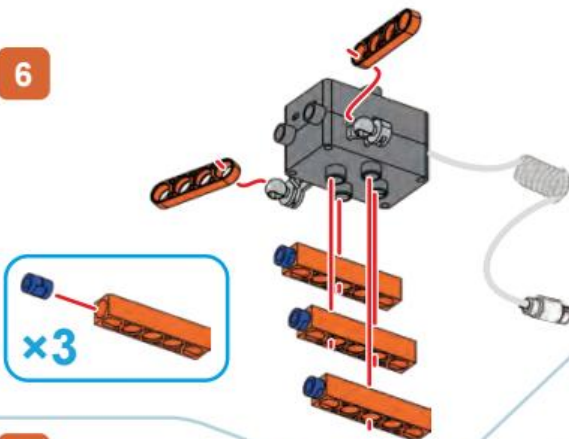

**7**

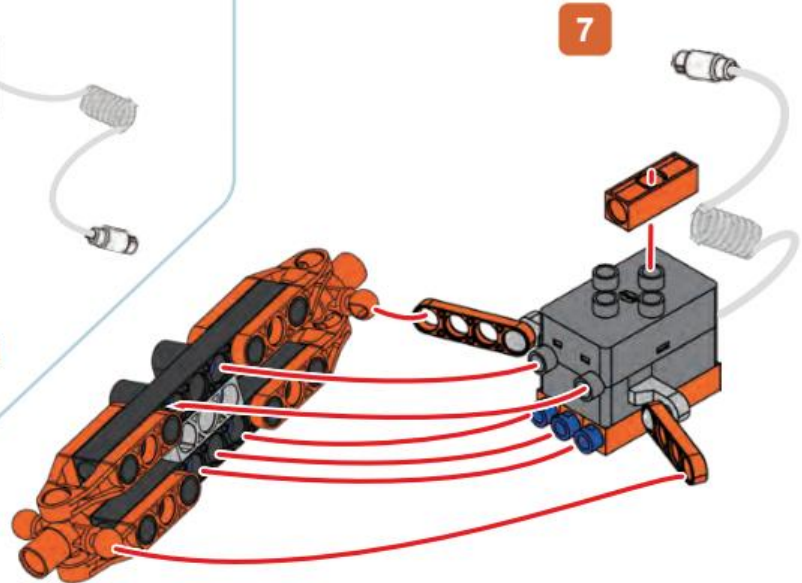

**8**



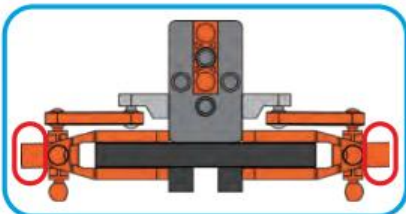

## Hot Rod Model 4

**9** 

**10**

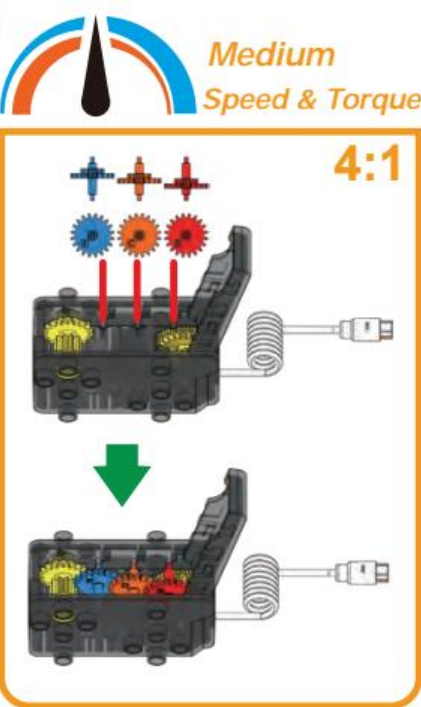
**11**   
*Medium Speed & Torque*  
**4:1**

**12**

**13**

**14**





**HOT ROD**

**Model 4 Hot Rod**

15

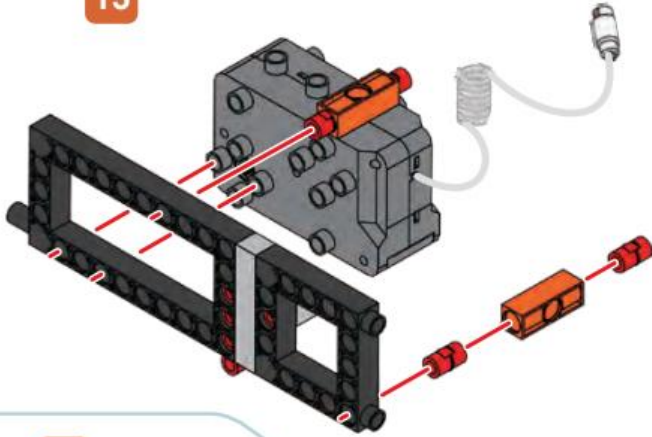

16

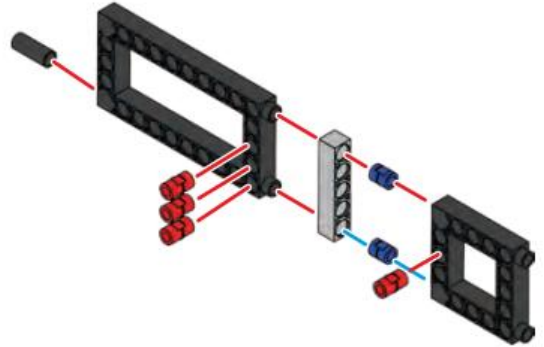

17

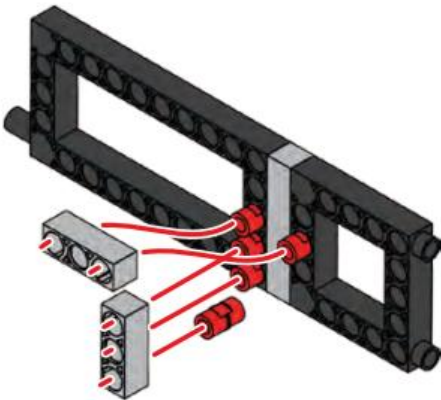

18

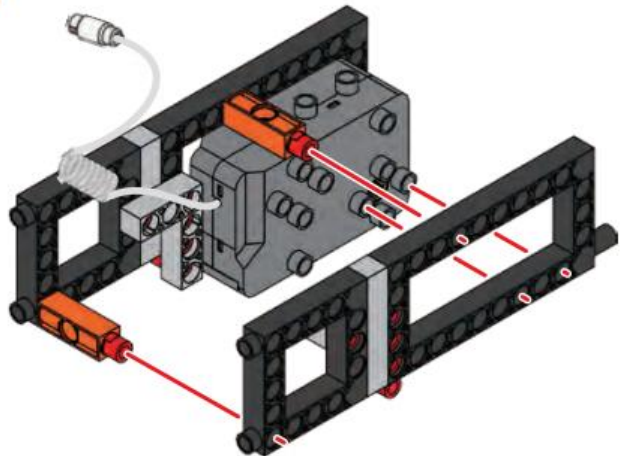

19

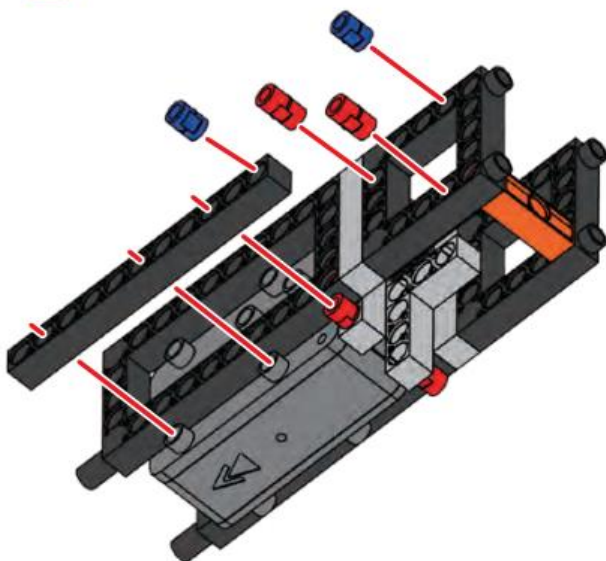

20

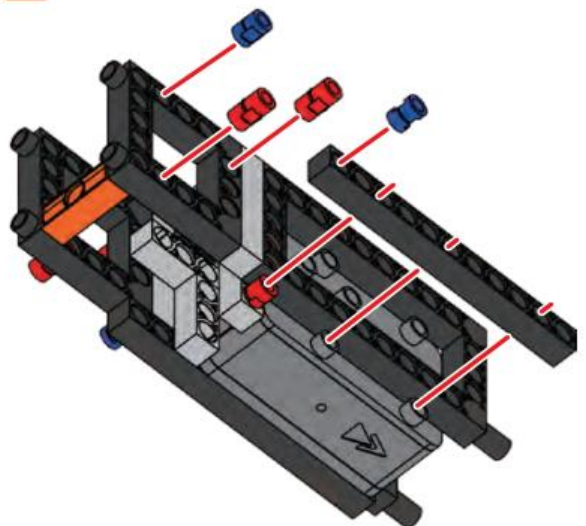



## Hot Rod Model 4

21

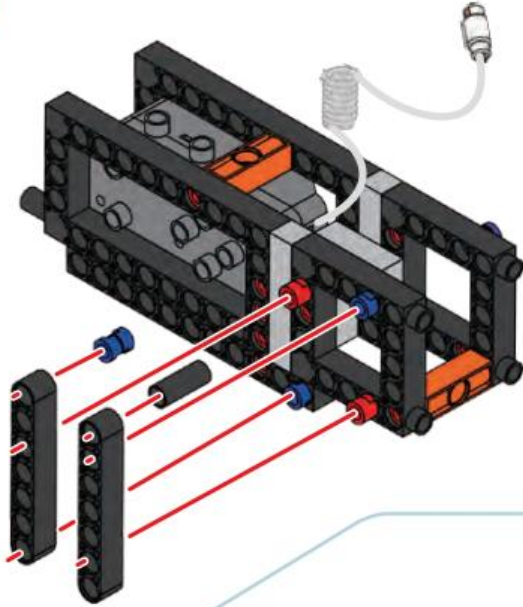

22

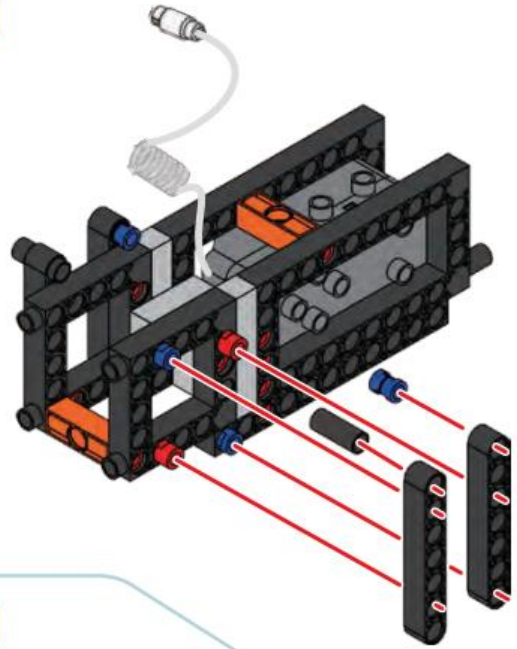

23

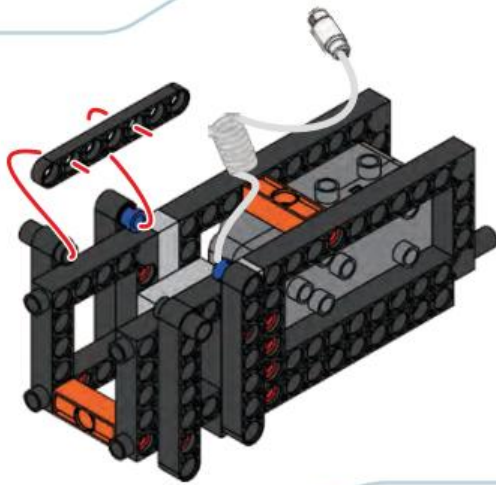

25

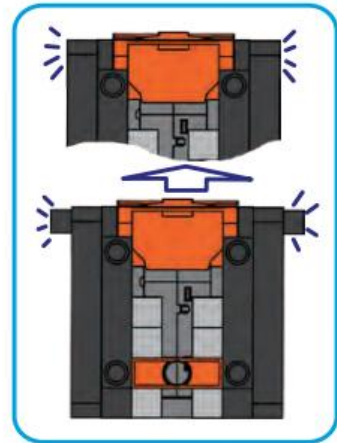

24

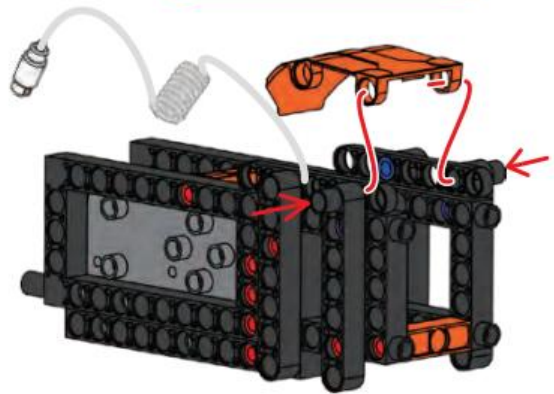
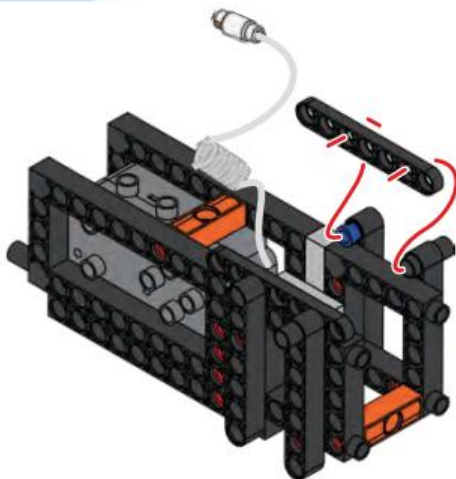



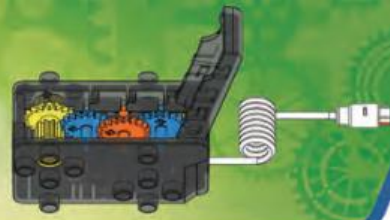

## HOT ROD

## Model 4 Hot Rod

26

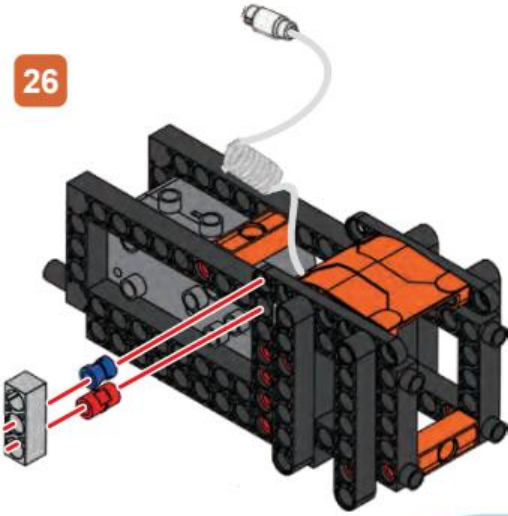

27

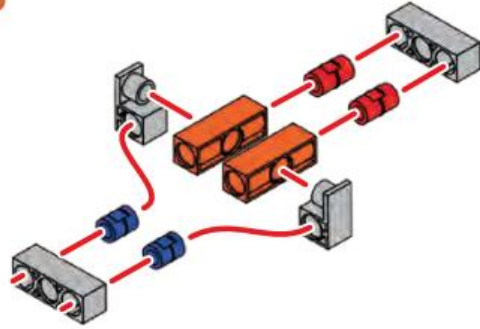

28

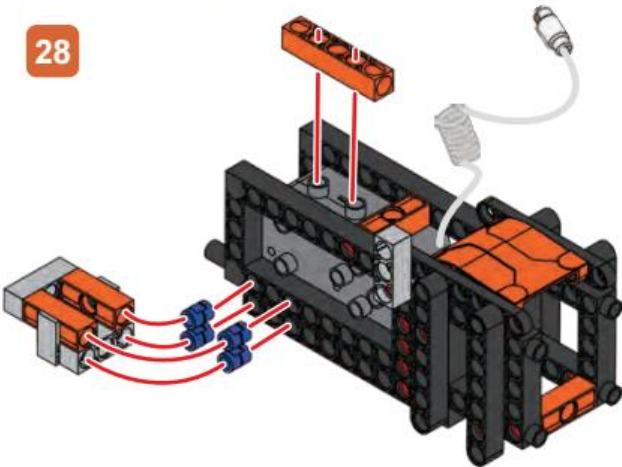

29

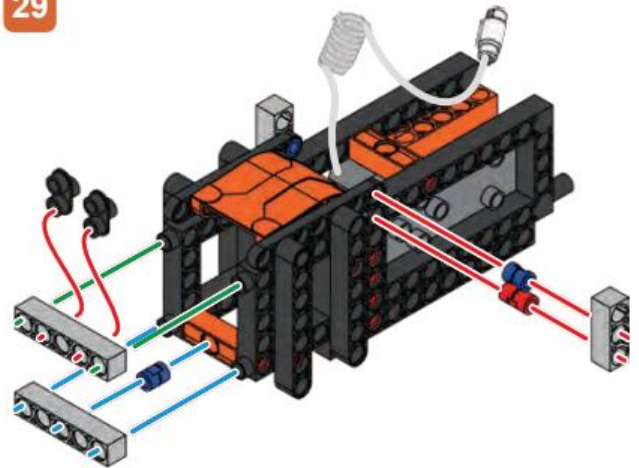

30

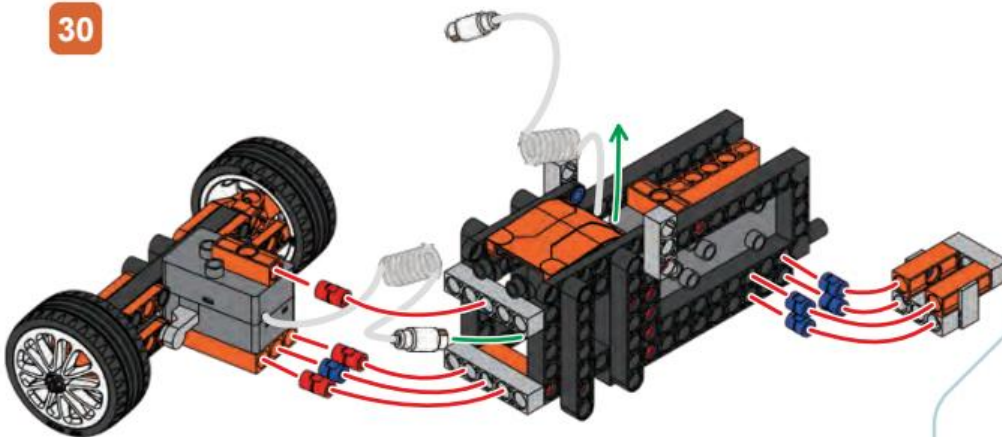

31

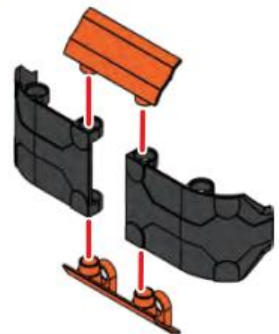



## Hot Rod Model 4

32

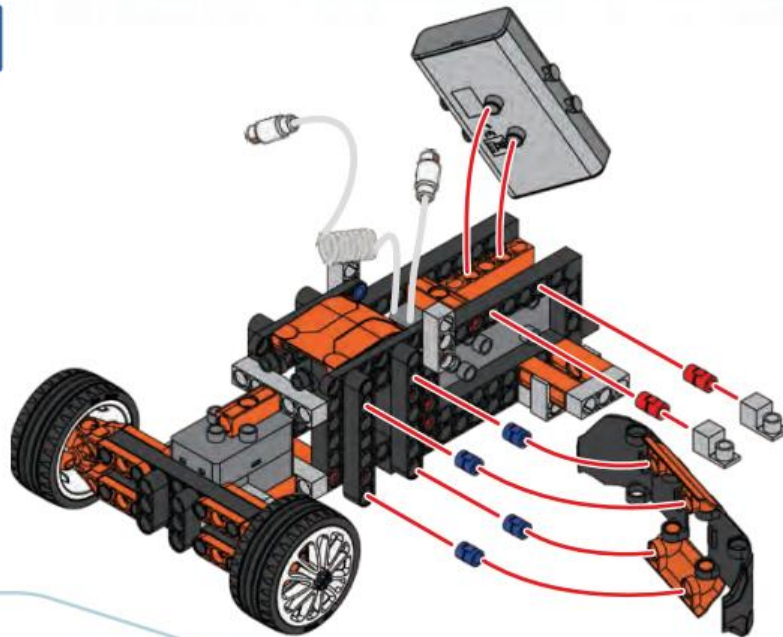

33

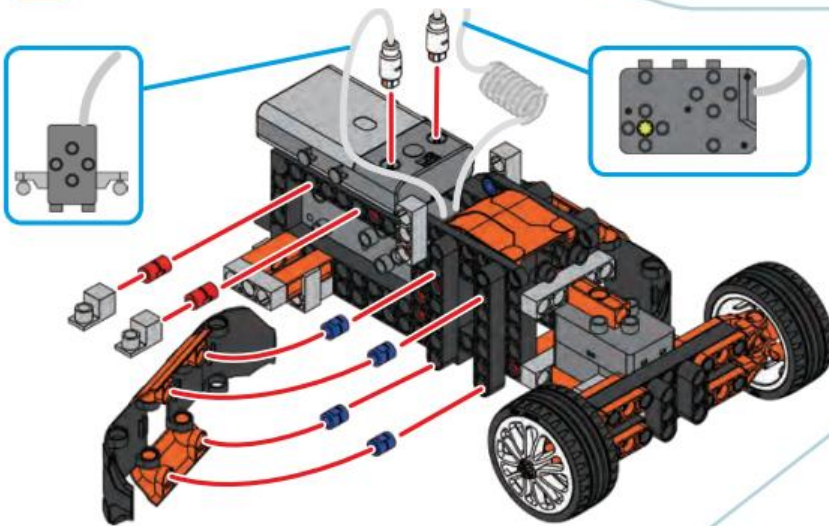

35

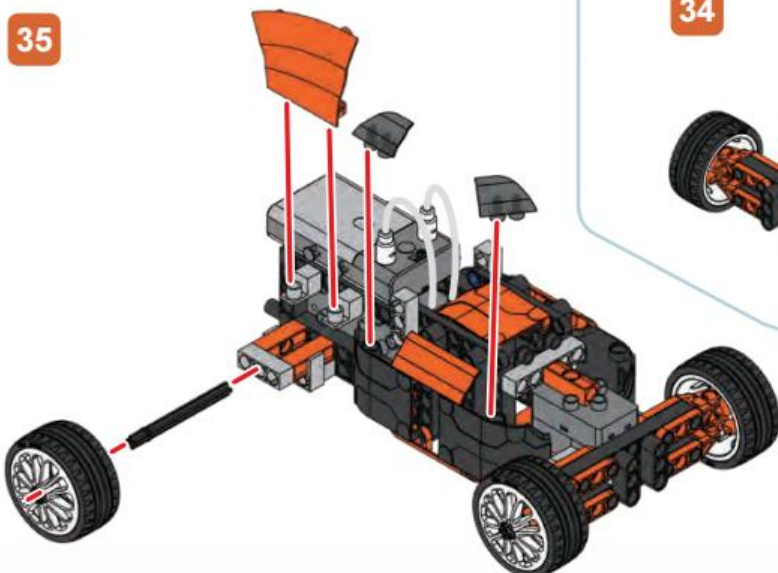

34

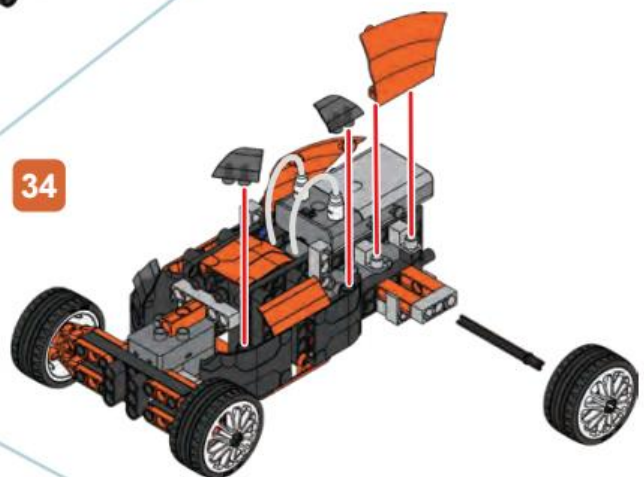





 HOT ROD

Model 4 Hot Rod

36

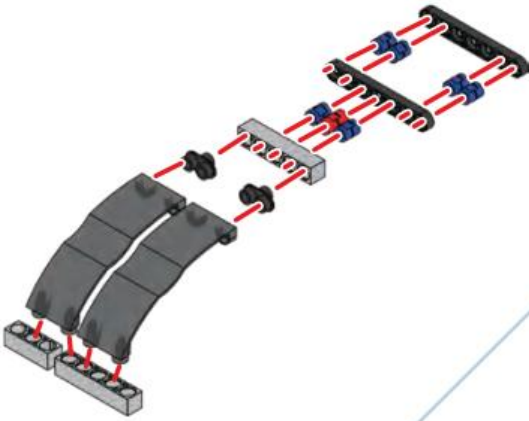

37

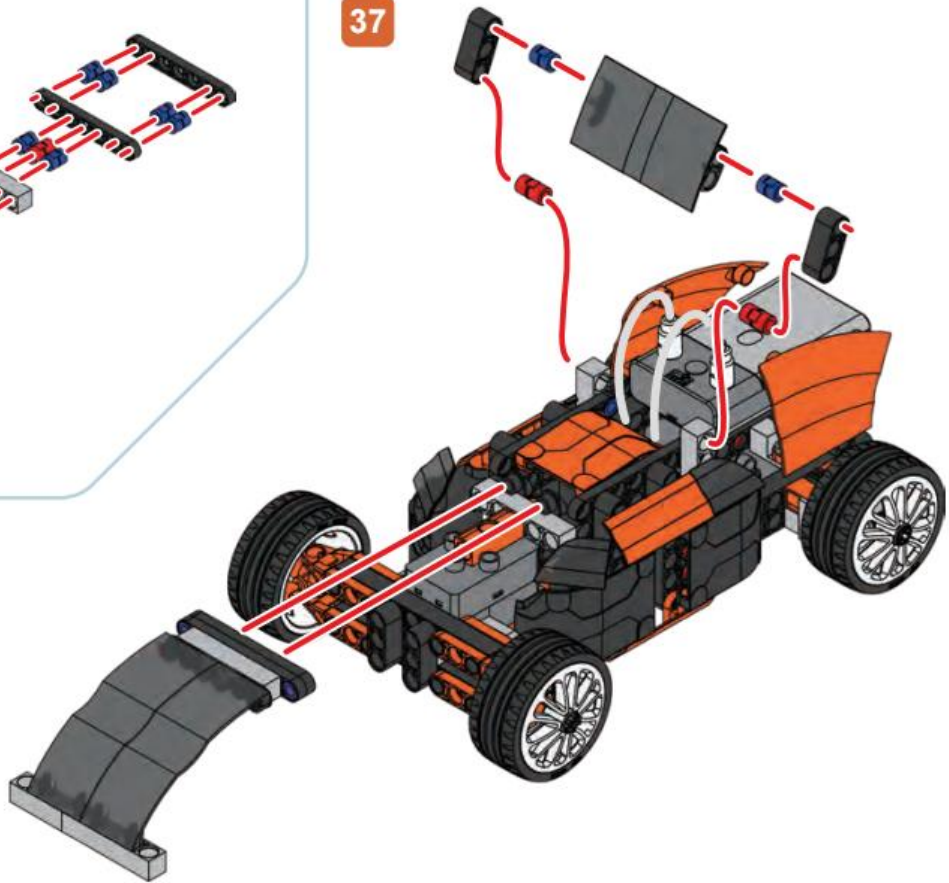

38

Done!

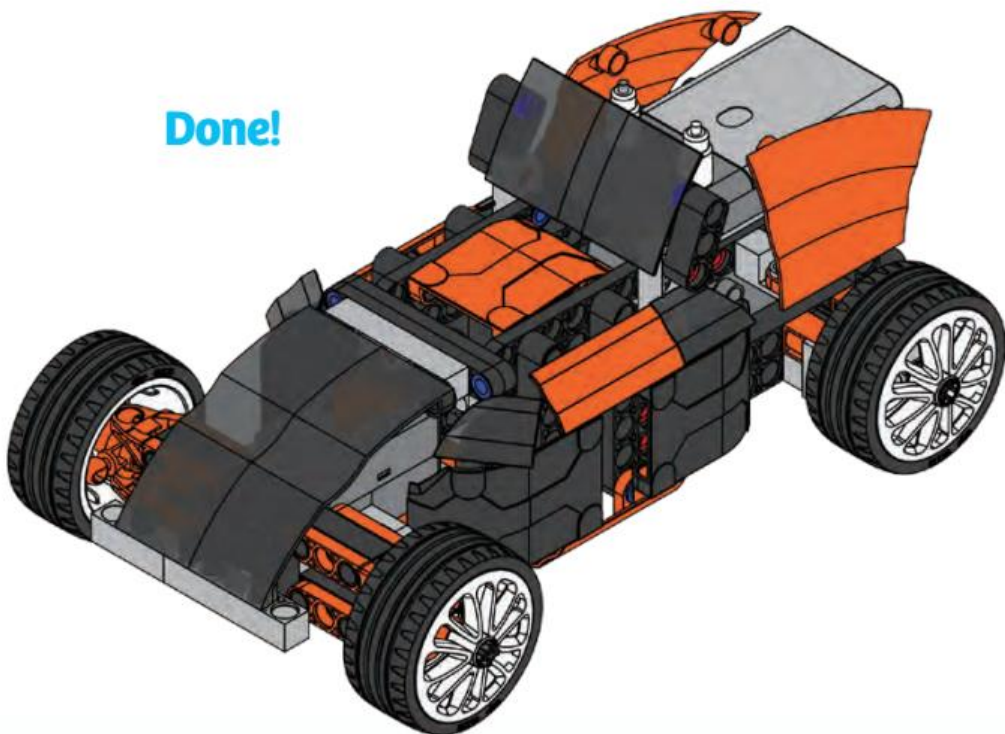





## CHECK IT OUT



## Famous Cars

### BENZ PATENT-MOTORWAGEN

The modern car was invented in 1886 by the German inventor Karl Benz. Karl Benz called his invention the Benz Patent-Motorwagen. Only around 25 were built!

In August 1888, Bertha Benz decided to promote the Patent-Motorwagen No. 3 by driving the first long distance journey by automobile. Along with her two sons, she went from Mannheim to Pforzheim in Germany. Bertha Benz acted as both a mechanic and a driver, fixing several mechanical issues that occurred during the trip.



### TOYOTA PRIUS

The Toyota Prius was the world's first mass-produced hybrid vehicle. Its popularity led to a revolution in the car industry as other car companies developed their own competing hybrid vehicles.



### FORD MODEL T

The Model T was one of the first cars that was accessible to the masses. The model T was first manufactured by the Ford Motor Company in 1908. The use of the moving assembly line allowed for production of more than 15 million Model Ts between 1908 and 1927.

### VOLKSWAGEN BEETLE

The Volkswagen Beetle is the most popular car ever produced. From its initial release in 1938 to final production in Mexico in 2003, more than 21 million Original Volkswagen Beetles were manufactured. Like the Ford Model T, the design of the Volkswagen Beetle was guided by the need for a simple, inexpensive car that could be mass-produced.





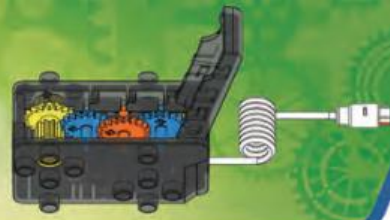

## HOT HATCHBACK

## Model 5 Hot Hatchback

### Parts Needed

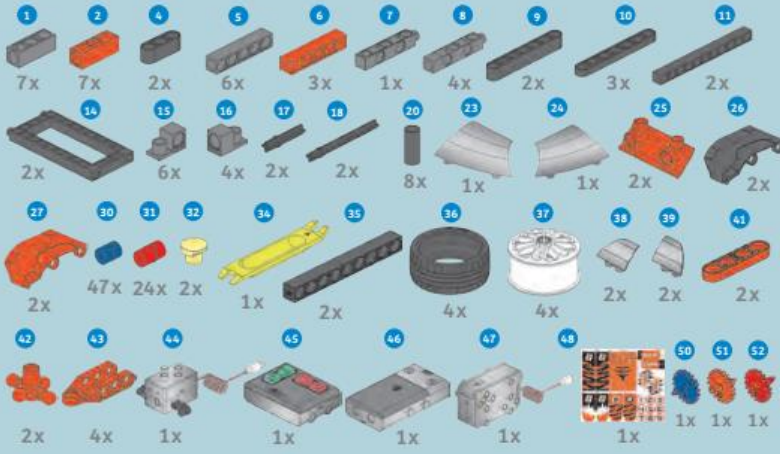

1 x2

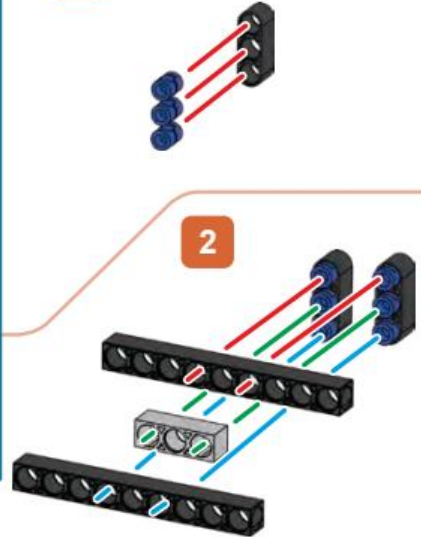

3 x2

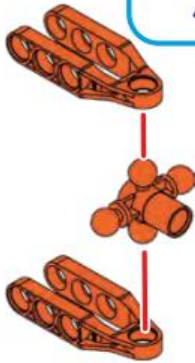
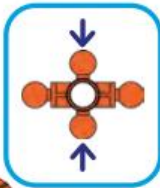

4

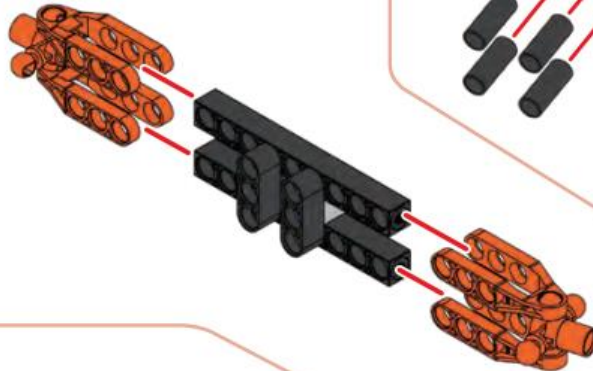

5

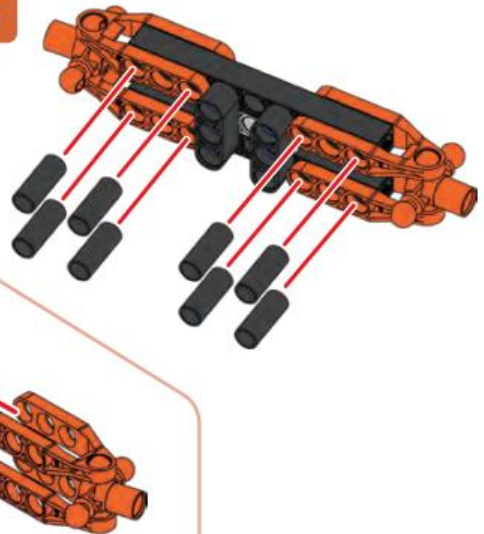

6

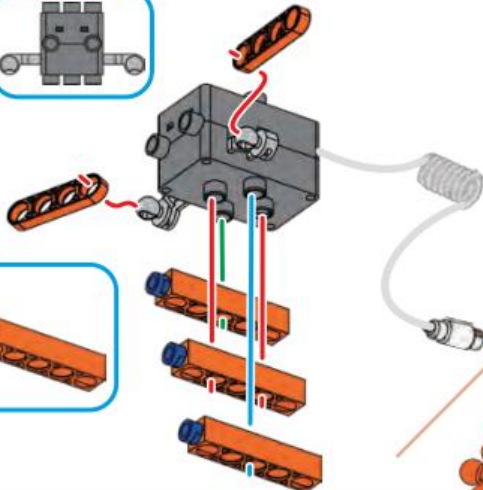
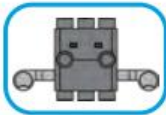

x3

7

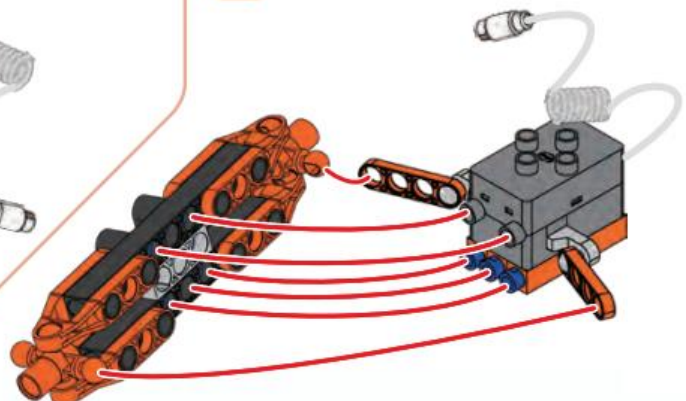



## Hot Hatchback Model 5

8 x4



9

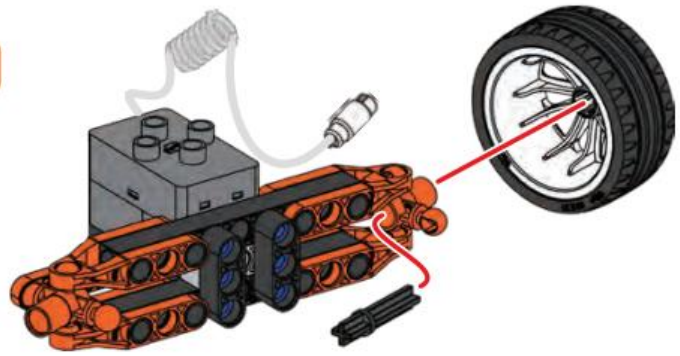

10

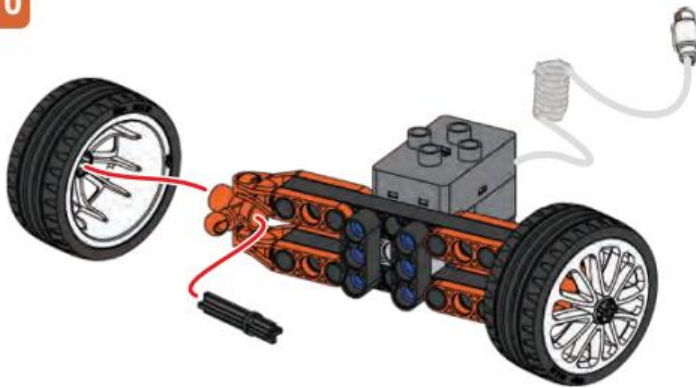

11



1:1

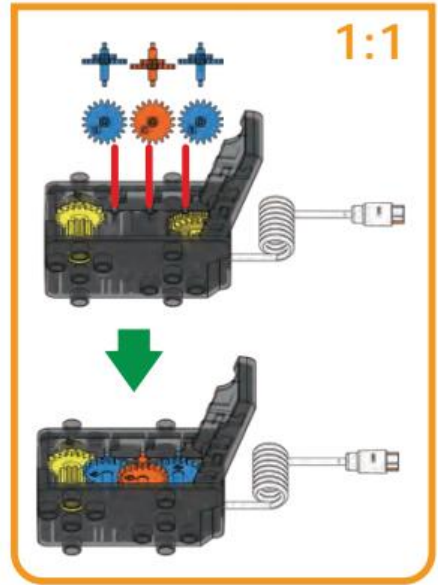

12

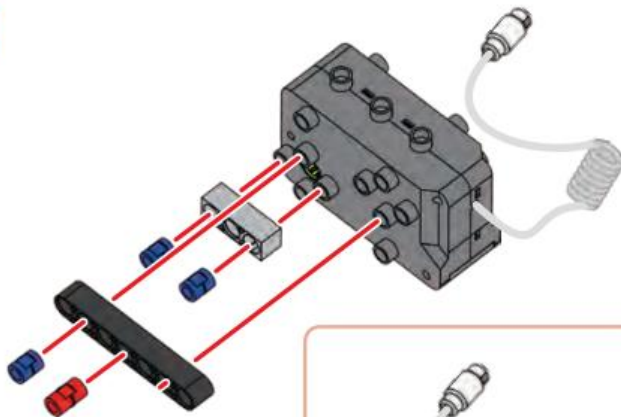

13

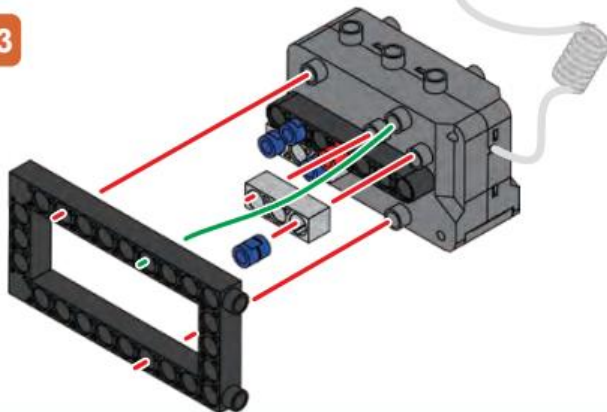

14

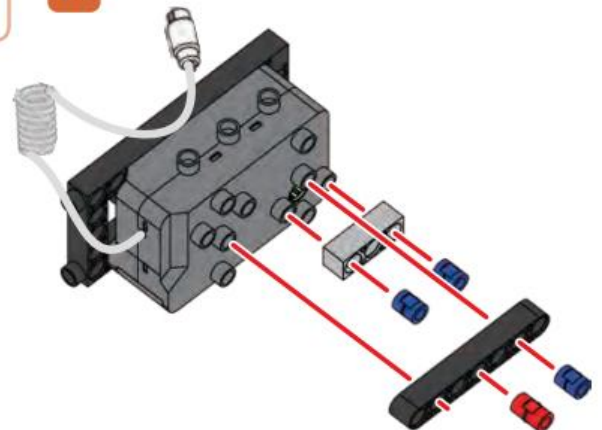





## HOT HATCHBACK

### Model 5 Hot Hatchback

15

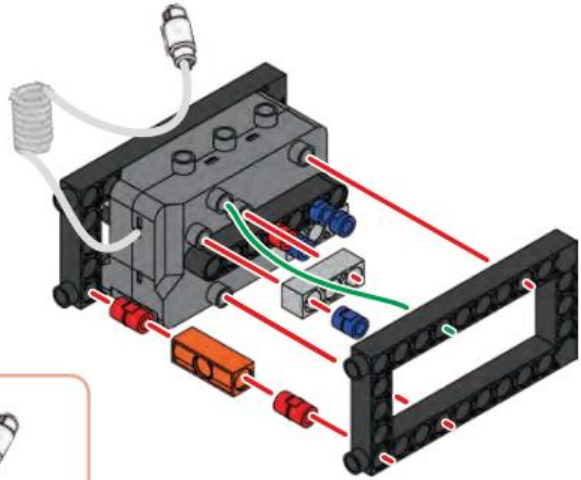

16

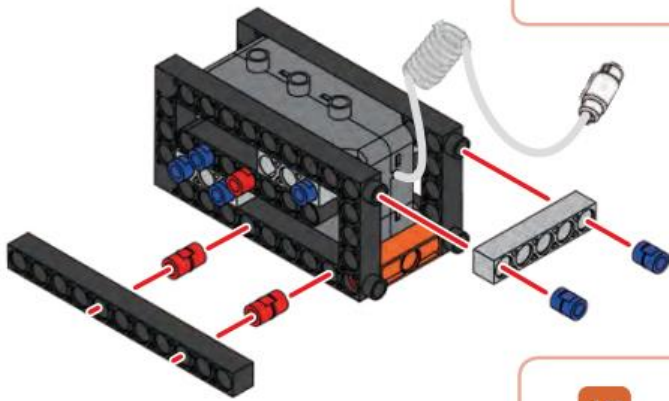

17

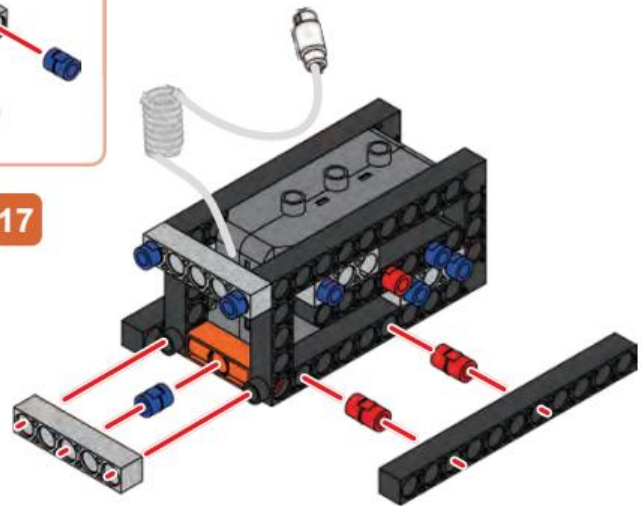

18

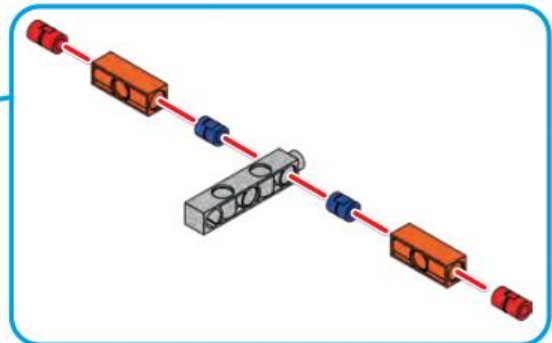
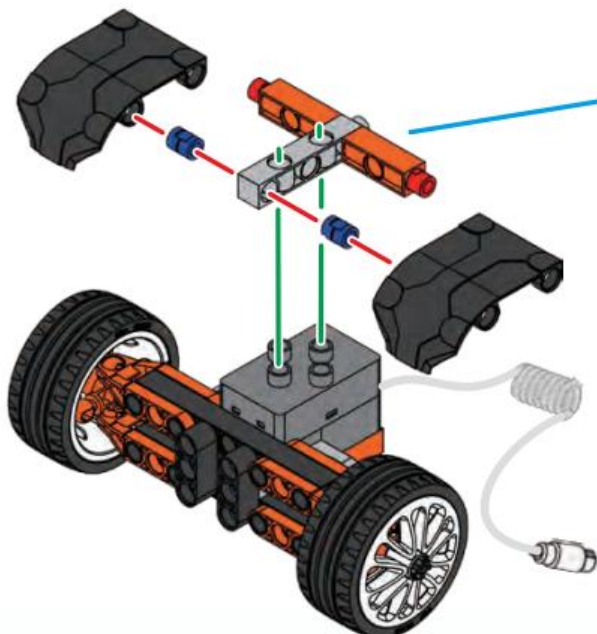



## Hot Hatchback Model 5

19

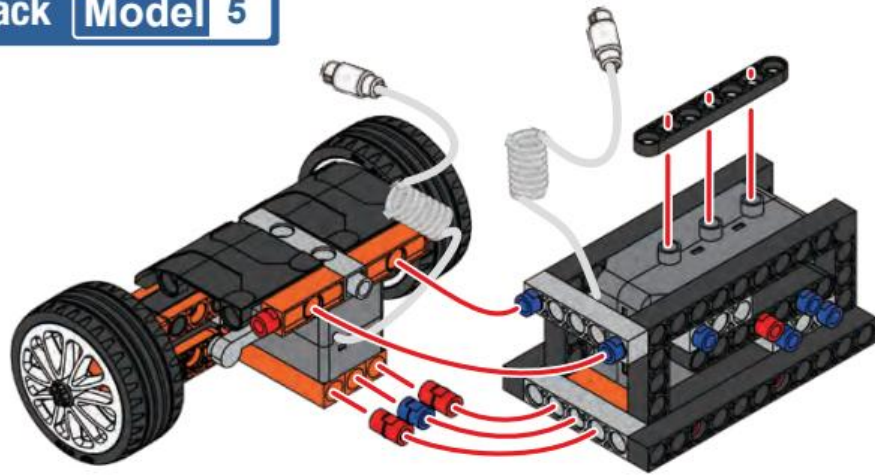

20 x2

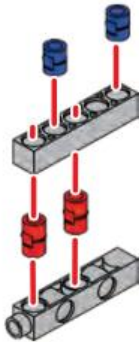

21

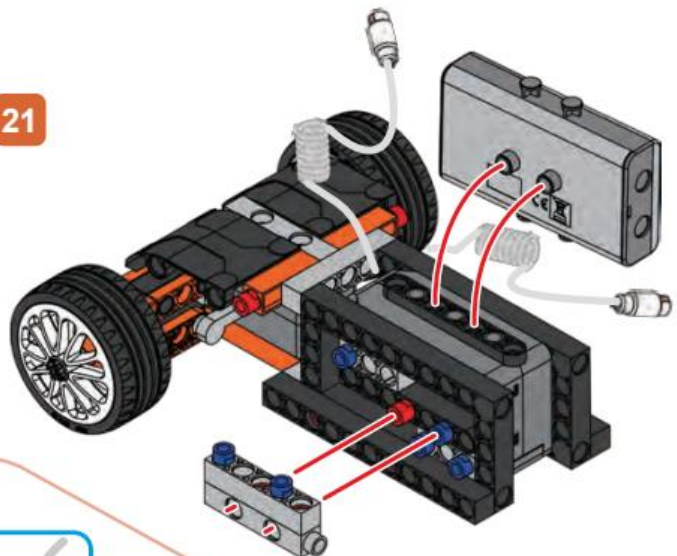

22

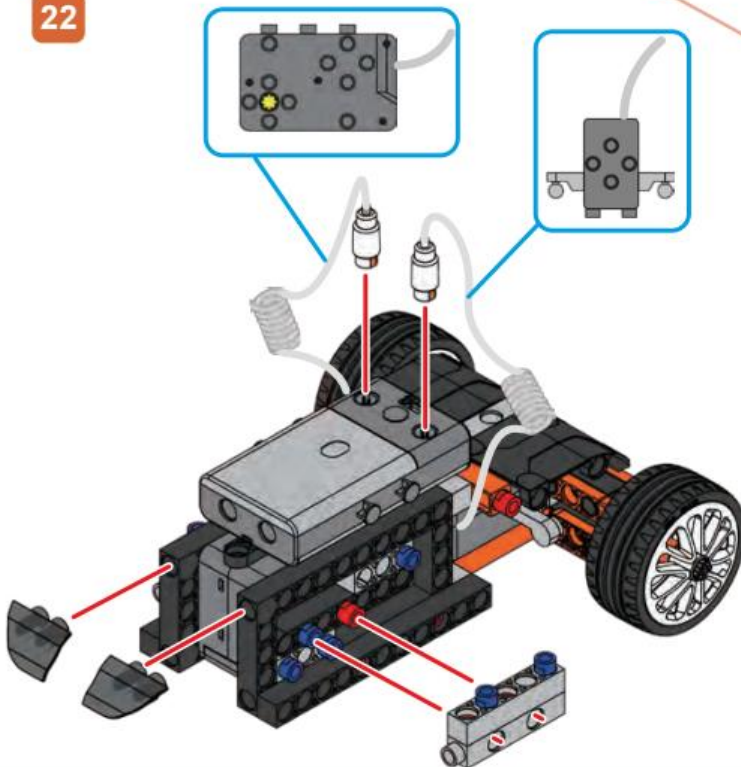

23

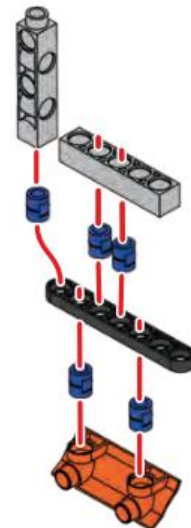





HOT HATCHBACK

Model 5 Hot Hatchback

24

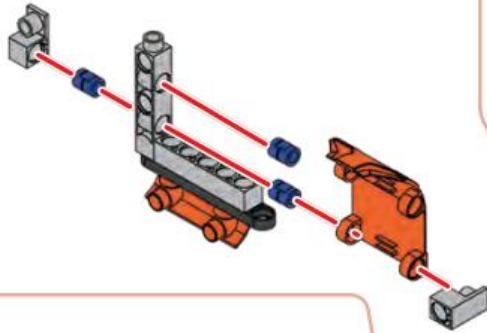

25 x2

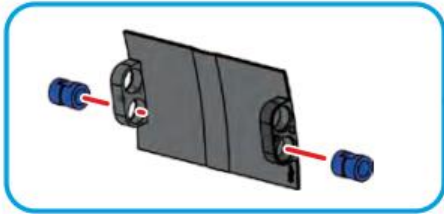
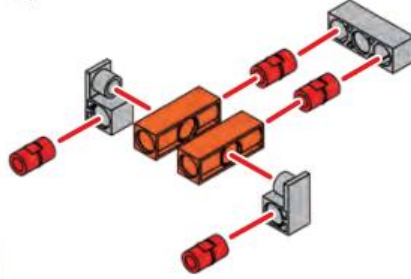

26

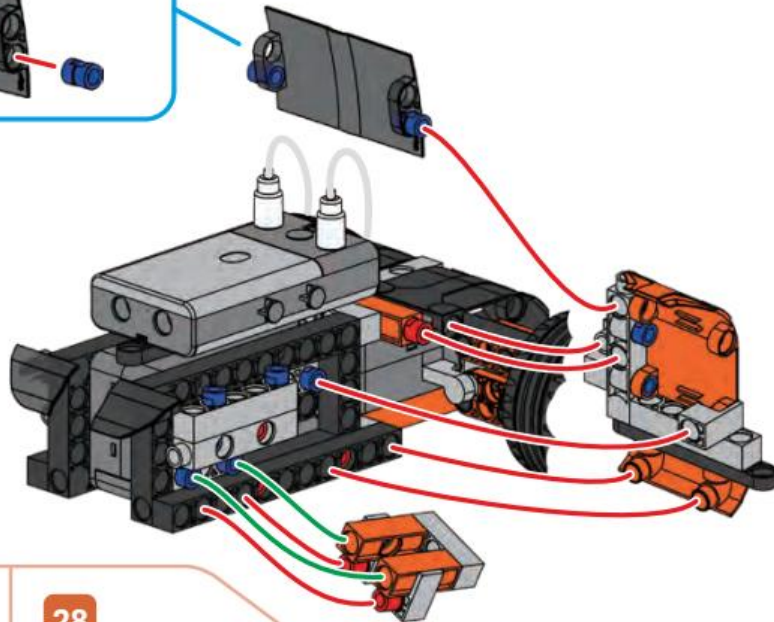

27

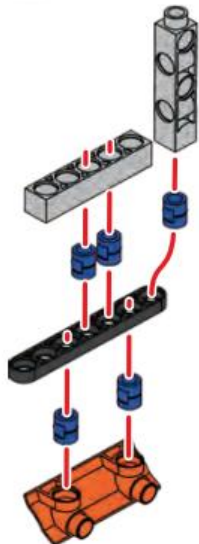

28

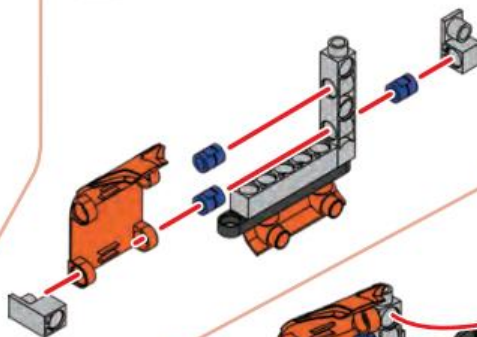

29

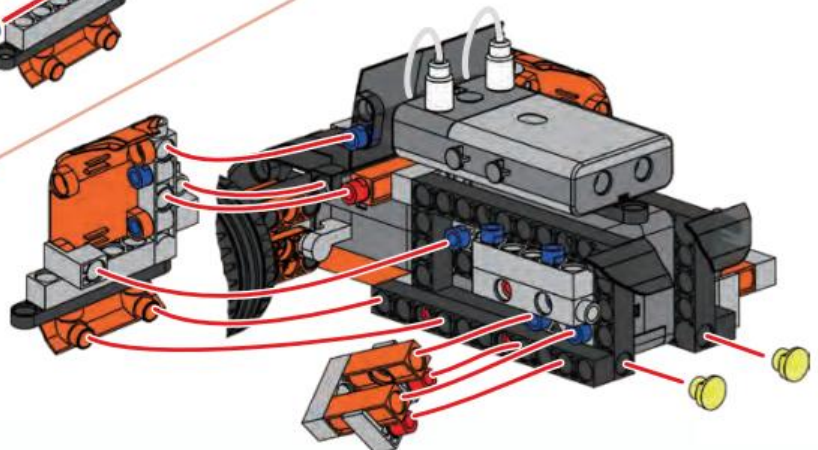



## Hot Hatchback Model 5

30

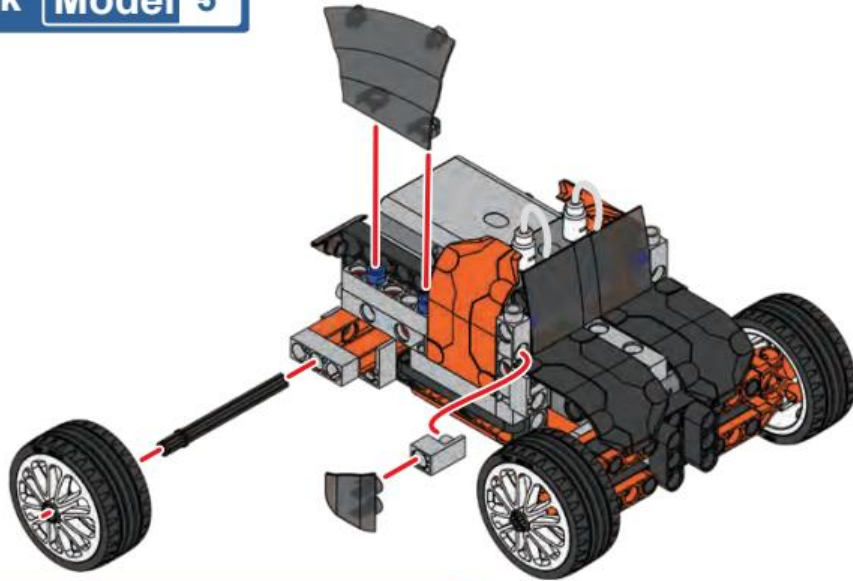

31

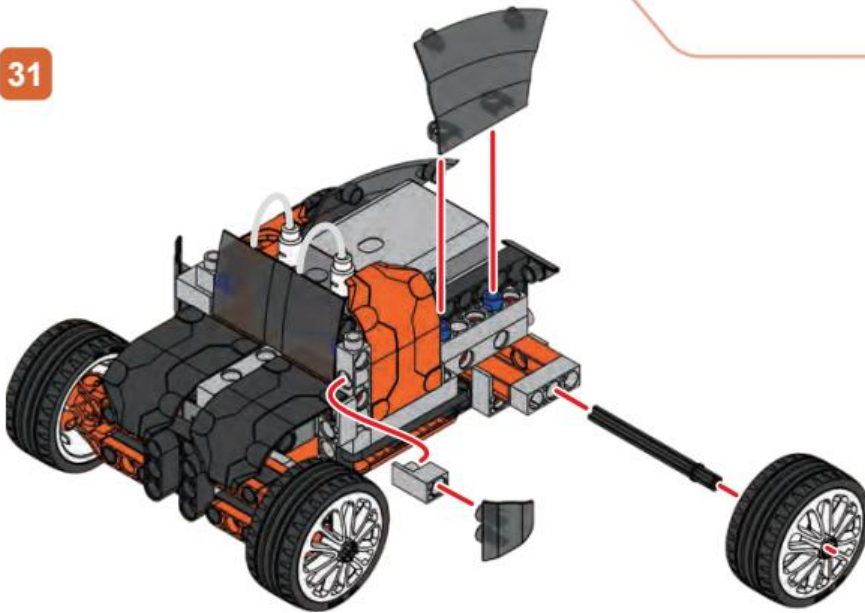

32

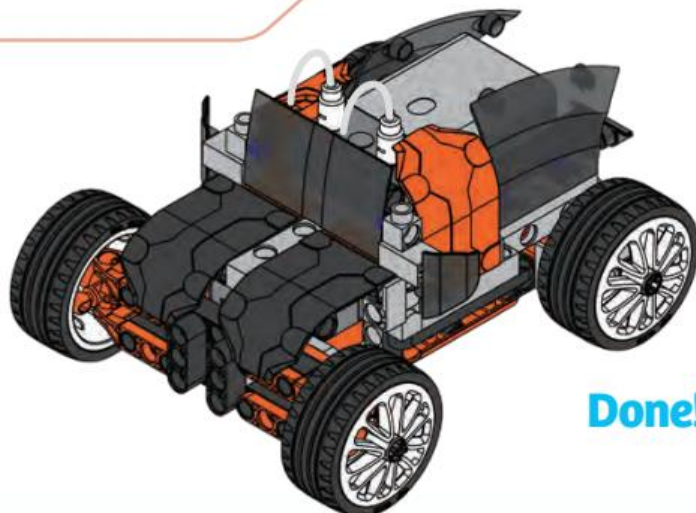

Done!



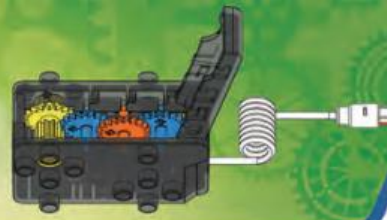

CHECK IT OUT



## Engineering a Race Car

An important goal of engineering a race car is minimizing **drag**. To understand what drag is, you first have to understand that the gases like the air we breathe and liquids like water behave similarly. When you move your hand through water with your palm facing the direction your arm is moving, it is a lot harder to move your hand than if your hand is on its side. The reason is that your palm provides a larger surface for the water molecules to bump into, creating more drag. Overcoming drag takes energy, so engineers have developed ways to both reduce drag and use it to make race cars faster.



### DOWNFORCE

The main way that drag is used to improve the car's performance is through the use of **downforce**. Downforce is, as the name suggests, a force due to air resistance that pushes down on a race car. This is accomplished by designing the car with a shape that creates a higher pressure on top of the car and a lower pressure underneath the car when the car is moving through the air. Downforce is used to keep the car tightly gripped to the road during turns.

### SIDE SKIRTS

Side skirts are used to keep the higher pressure volumes of air on the side of the car and the lower pressure air on the bottom.

Side skirts are also used on semi-trucks to make them more efficient.



### SUPER CHARGER

A super charger is used to push air into the engine. This gives a boost to the horsepower of a race car, because the greater air intake allows the engine to burn fuel at a faster rate.







## Go-Kart Model 6

### Parts Needed

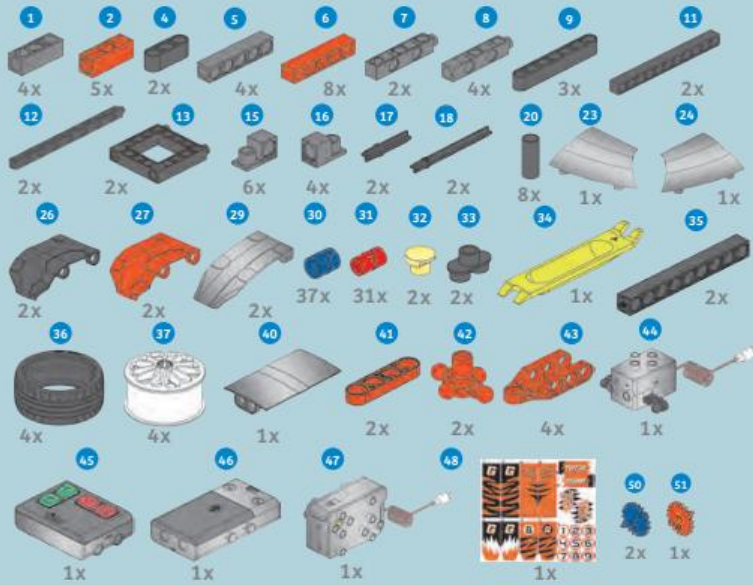

1 x2



2

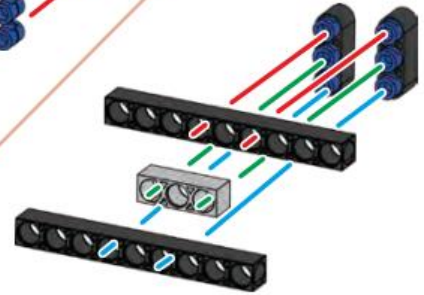

5

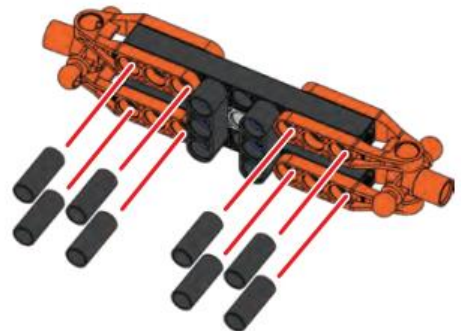

3 x2

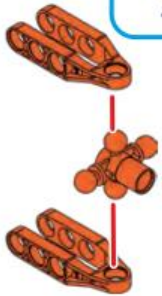

4

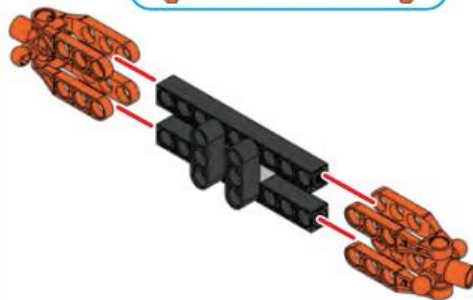
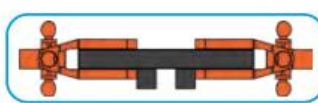

6

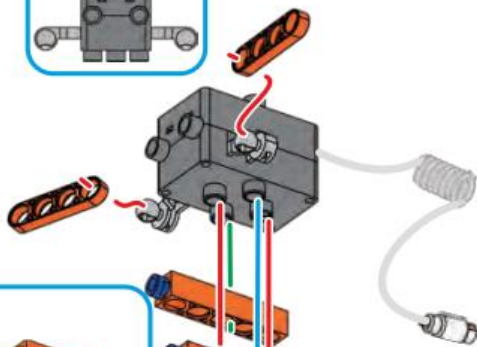
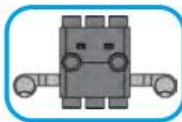

x3

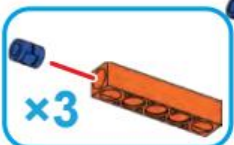

7

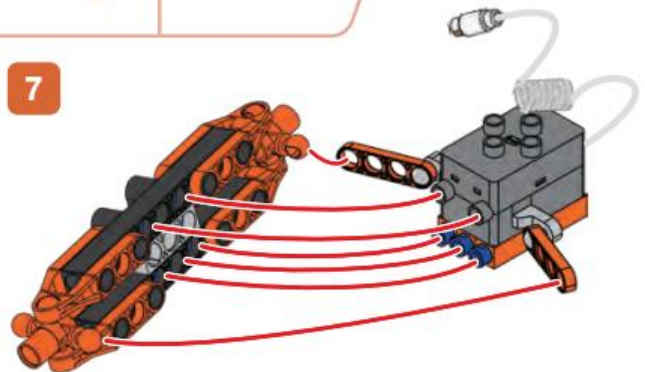

8 x4





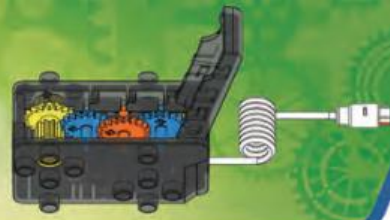

9

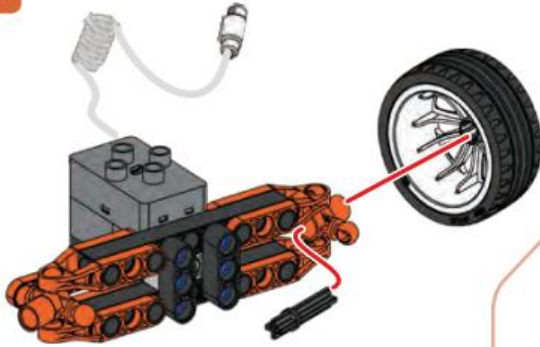

10

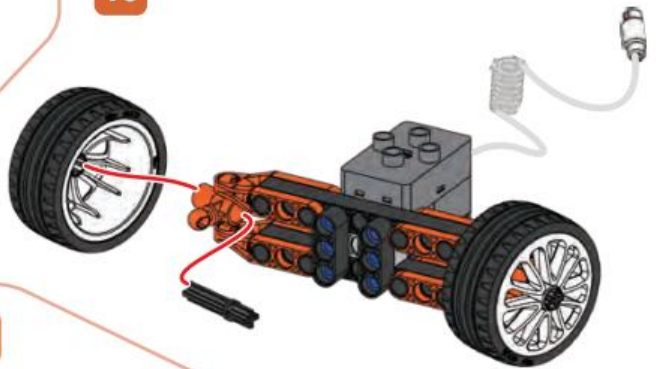

11



High Speed  
Low Torque

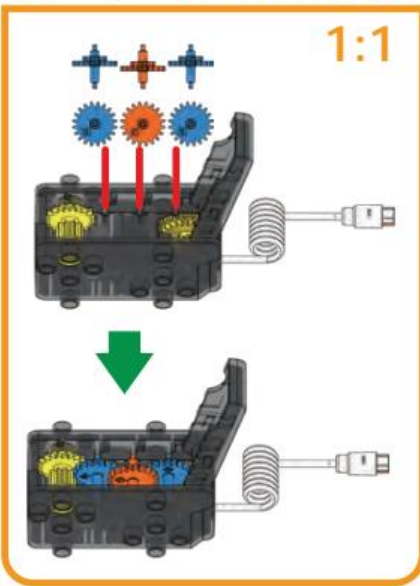

12

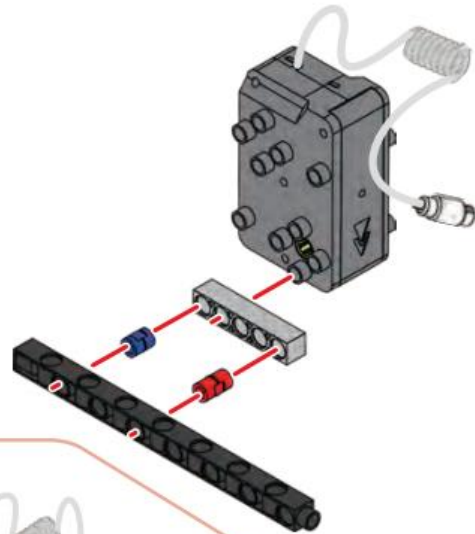

13

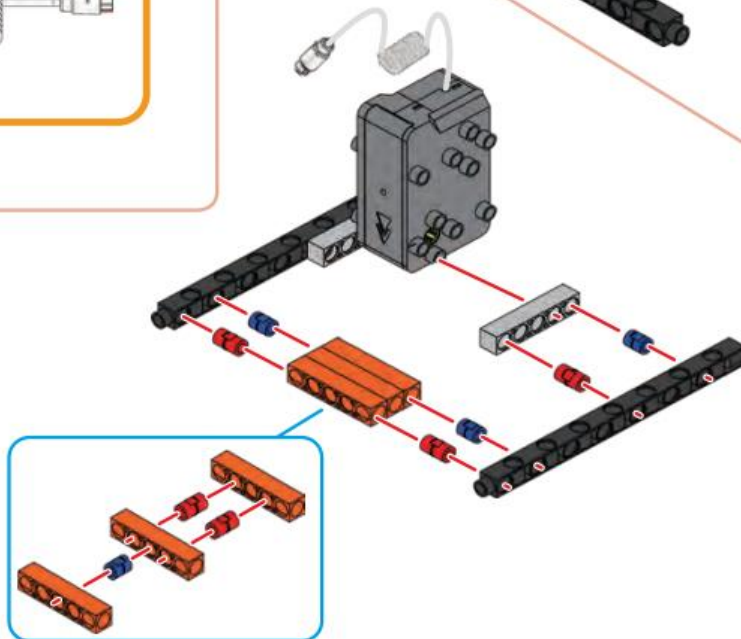



## Go-Kart Model 6

14

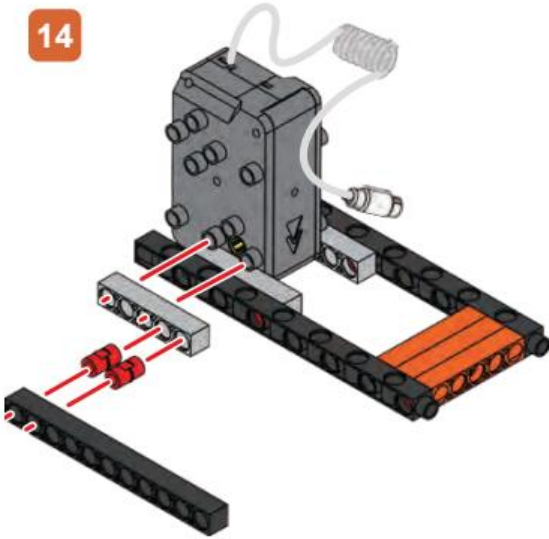

15

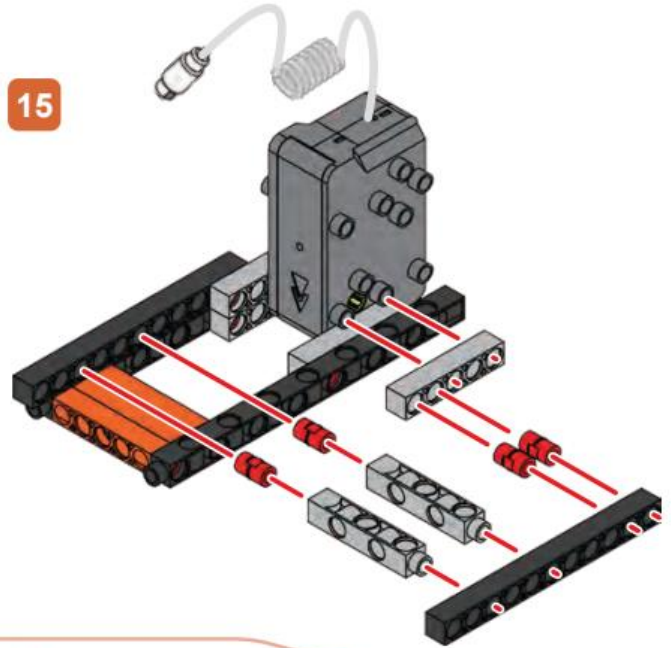

16 x2

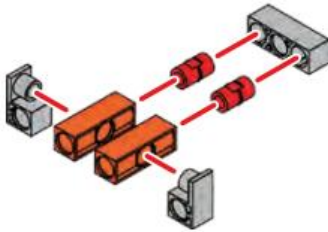

17

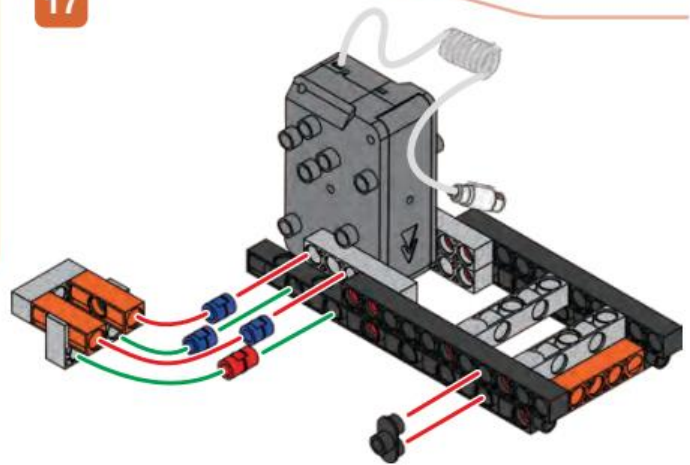

18

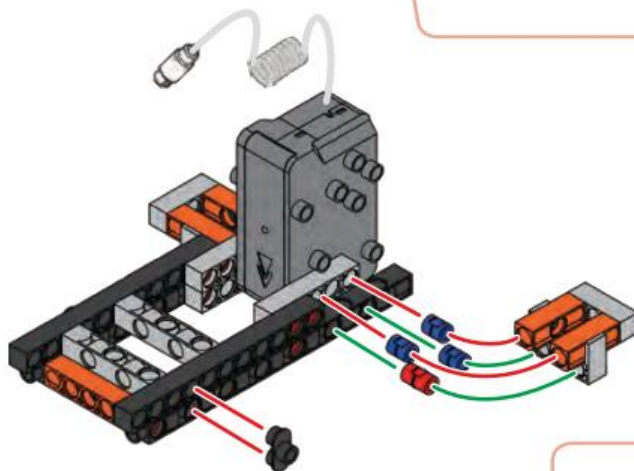

19

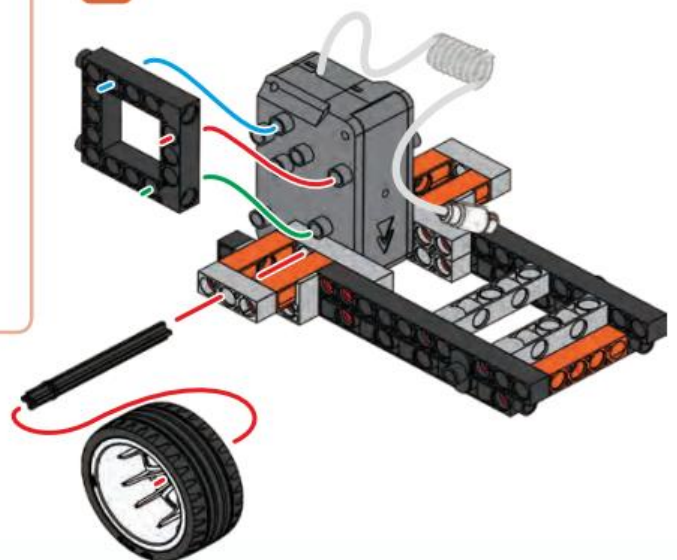



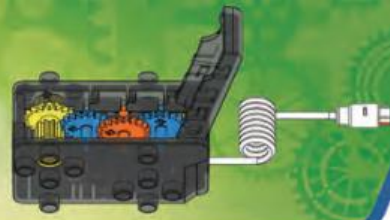

20

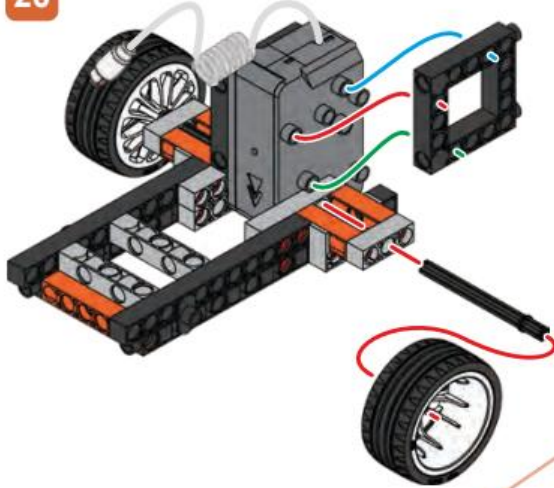

21

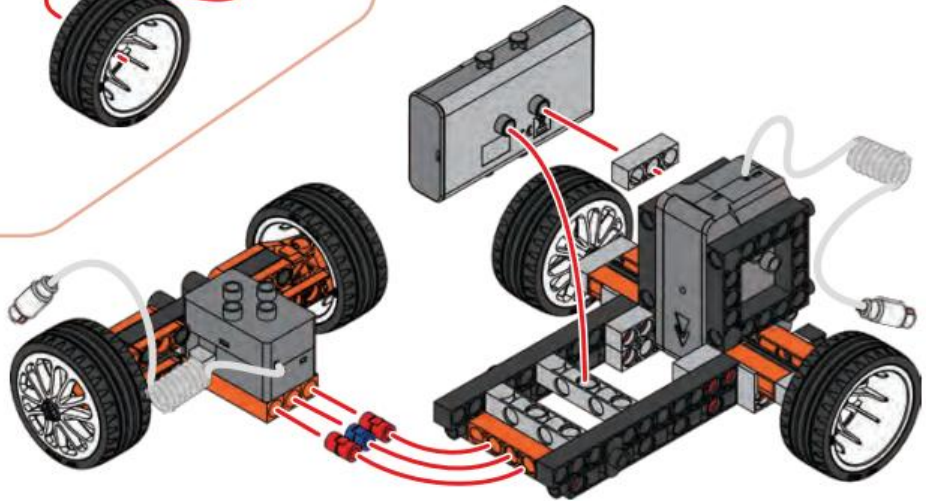

22

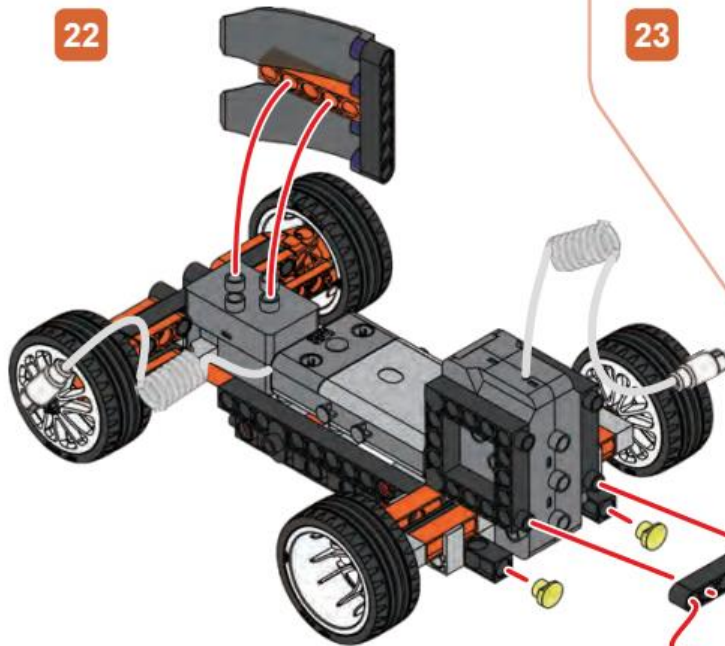

23





## Go-Kart Model 6

24

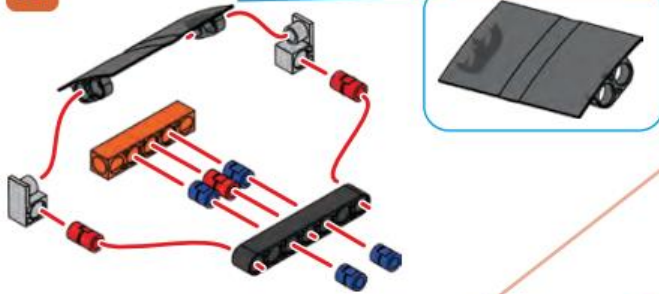

26

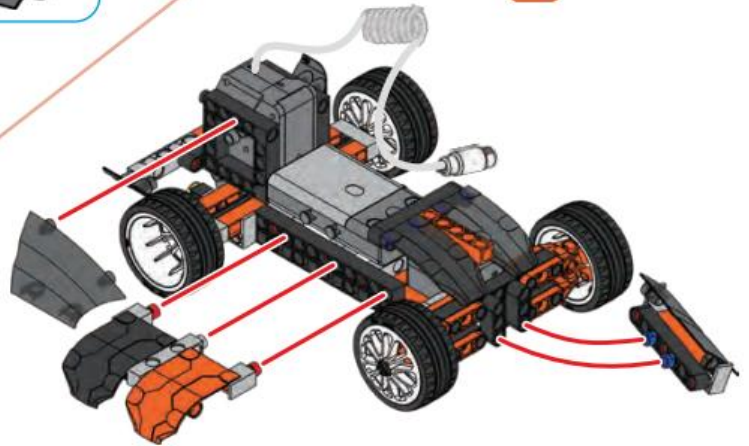

25

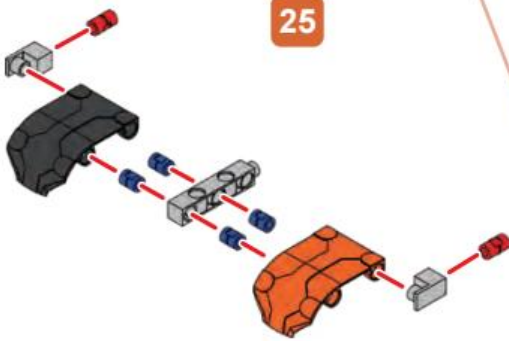

27

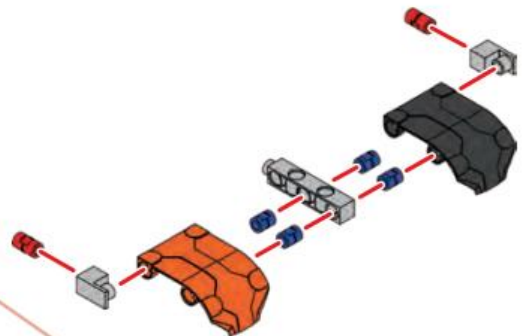

28

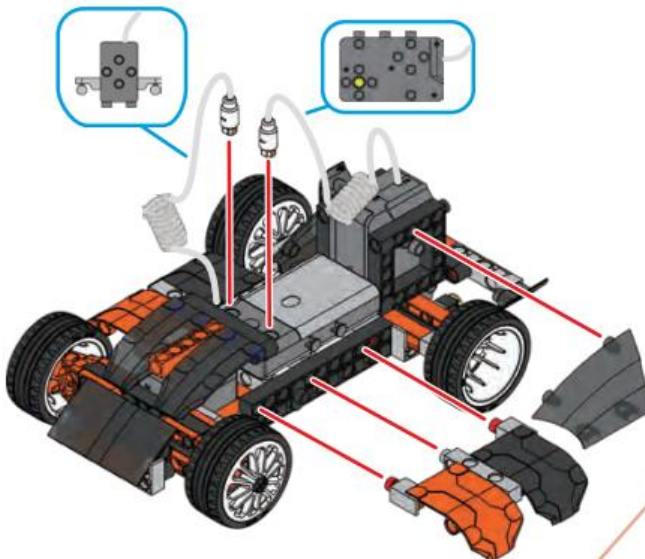

29

Done!

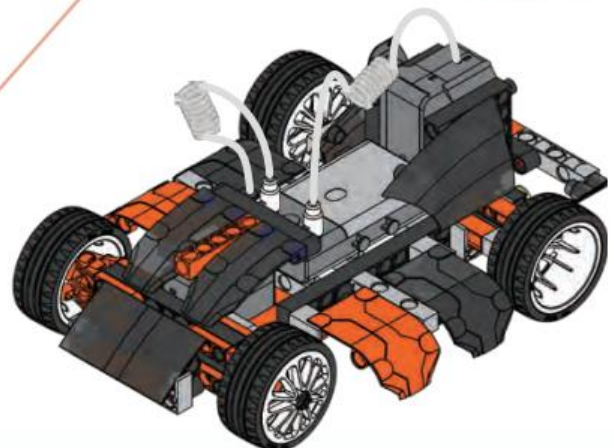



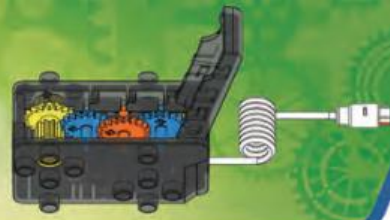

## PICKUP TRUCK

## Model 7 Pickup Truck

### Parts Needed

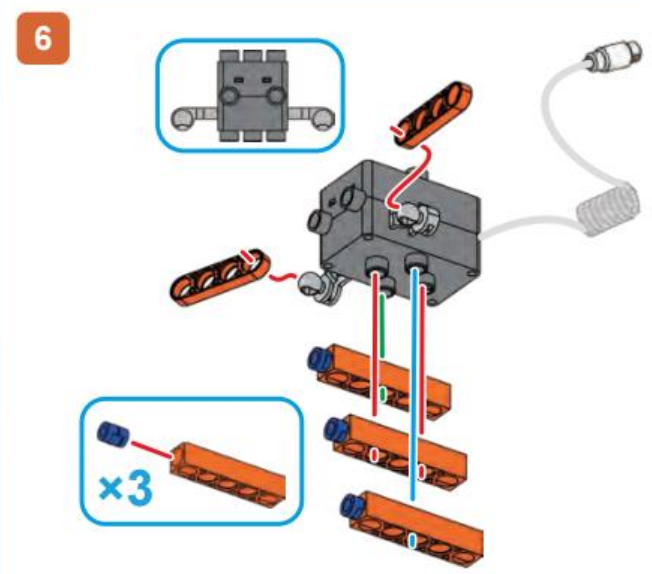
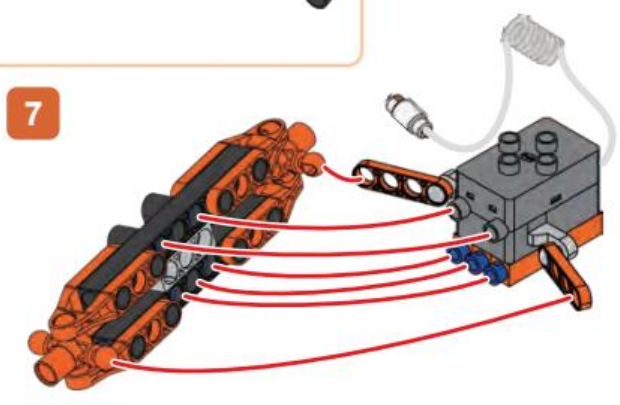
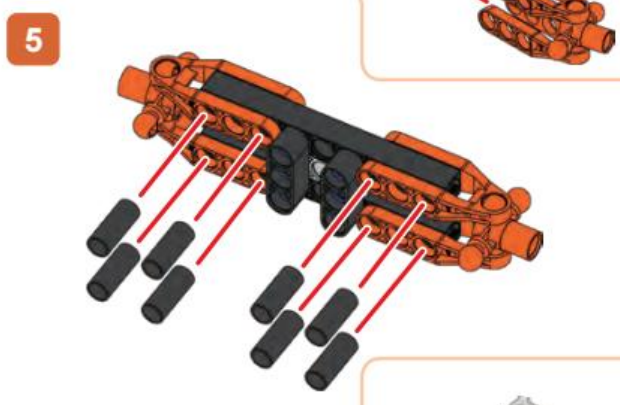
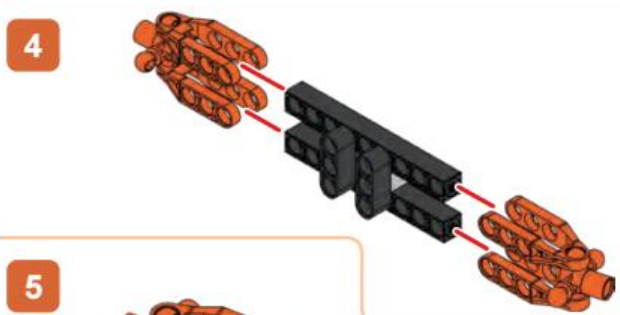
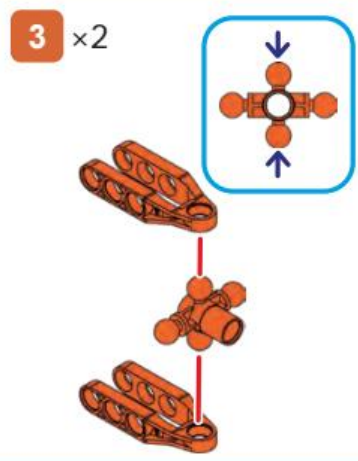
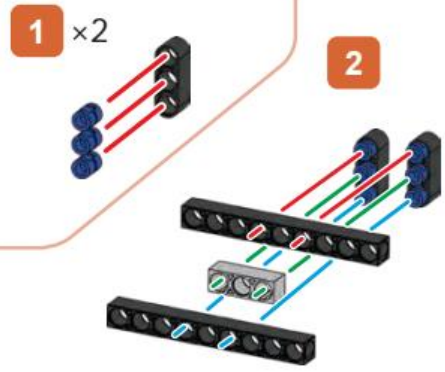
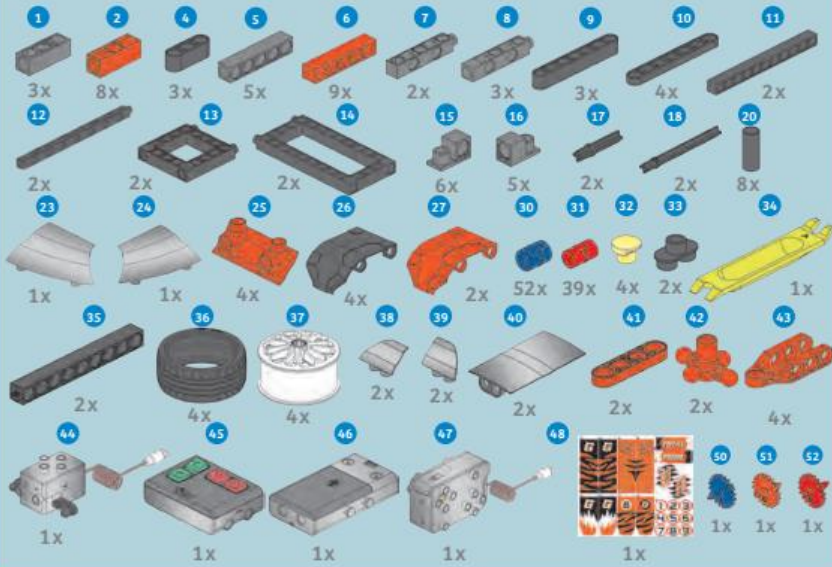



## Pickup Truck Model 7

9

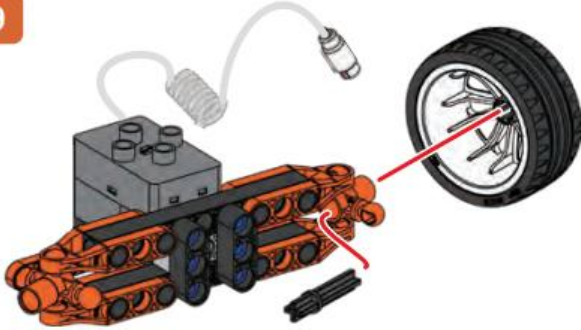

10

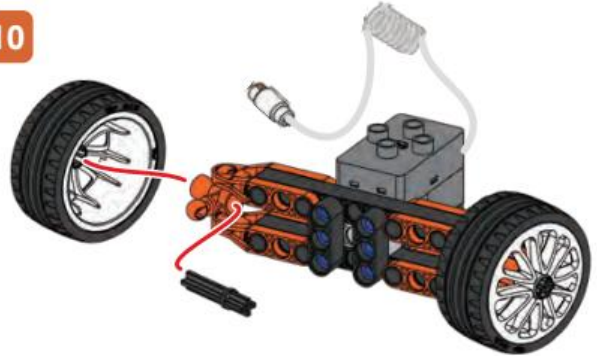

11

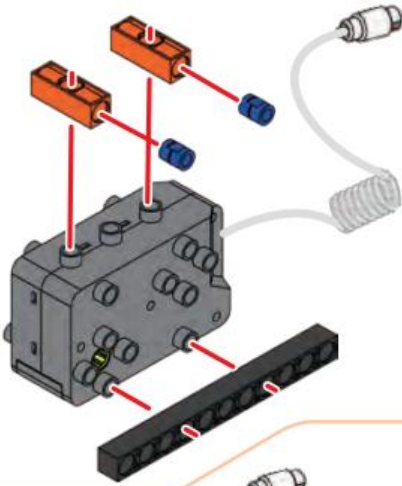

12

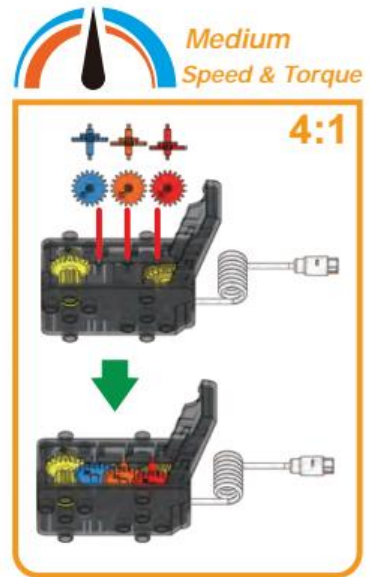

13

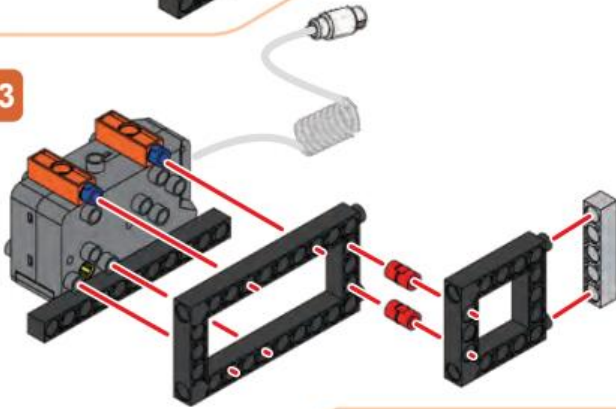

15

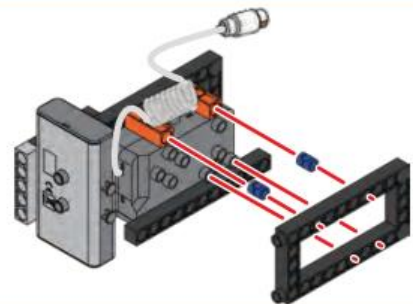

14

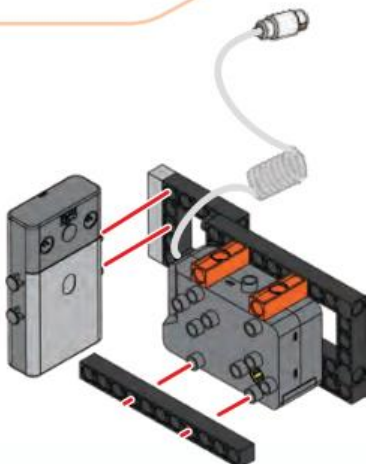

16

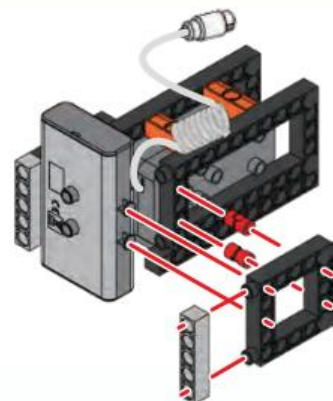





PICKUP TRUCK

Model 7 Pickup Truck

17 x2

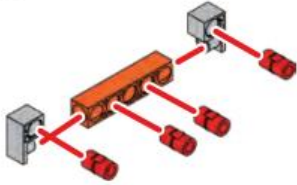

18

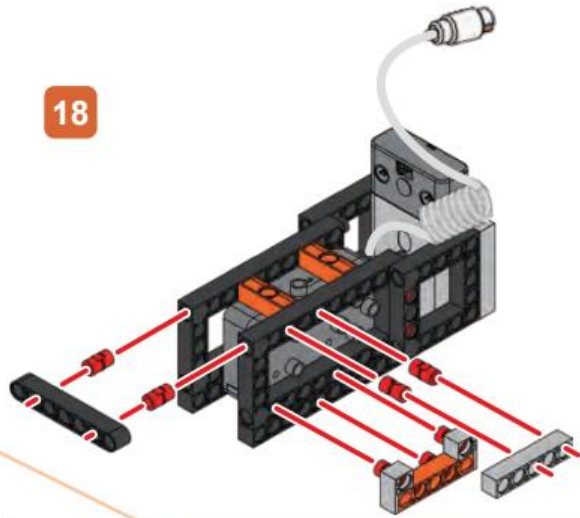

19

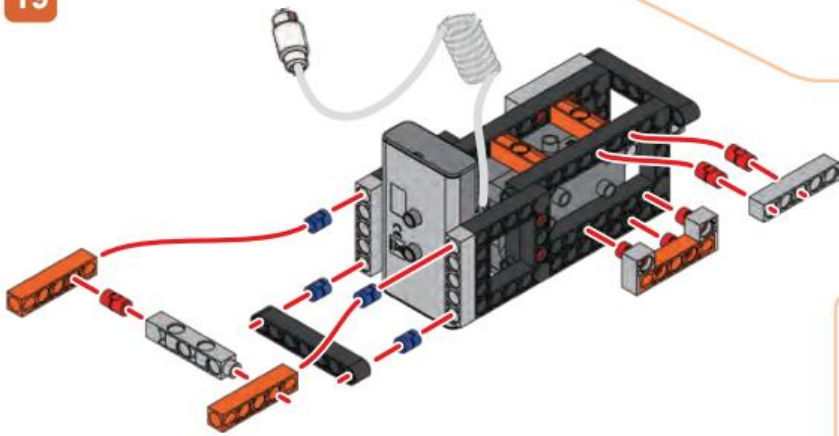

20

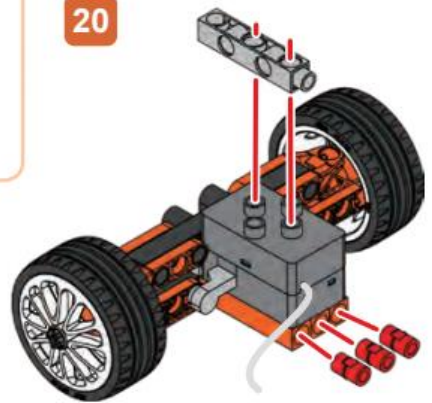

21

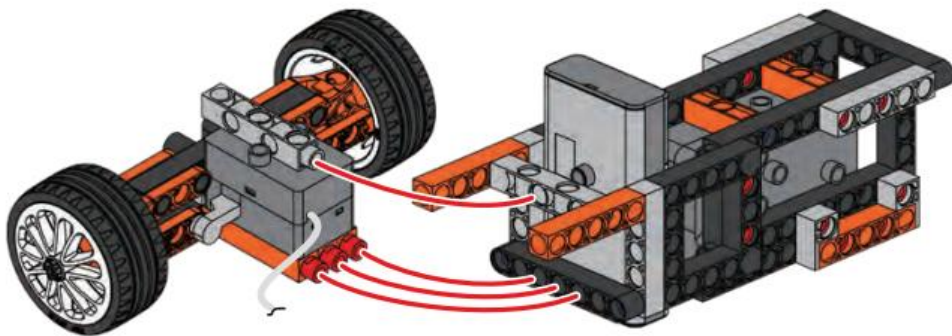

22 x2

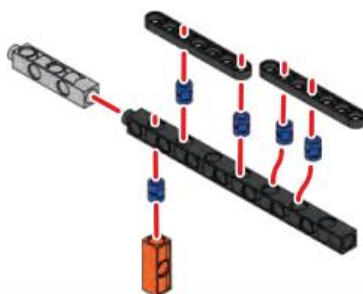



## Pickup Truck Model 7

23

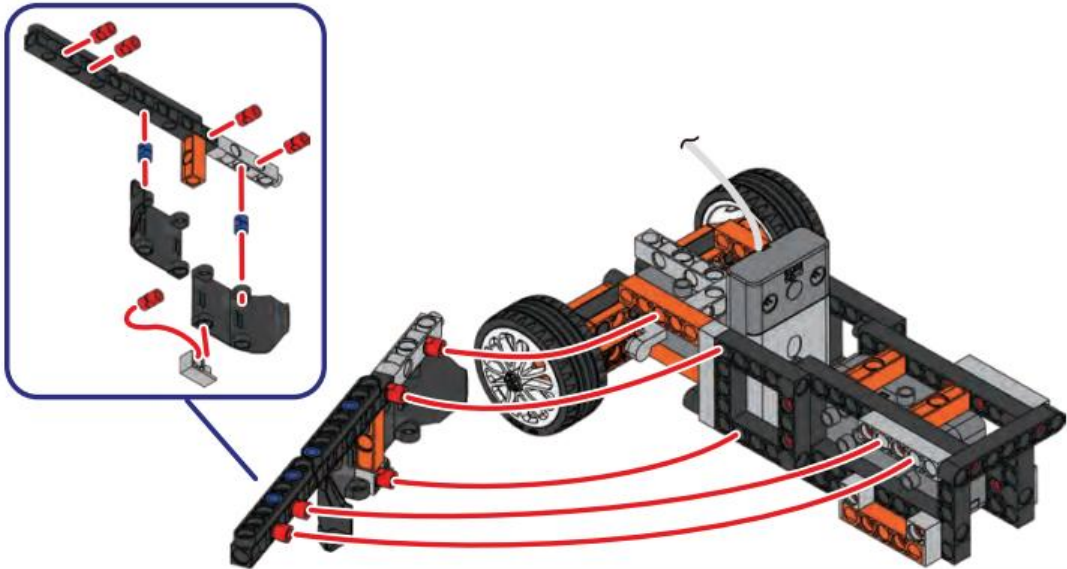

24

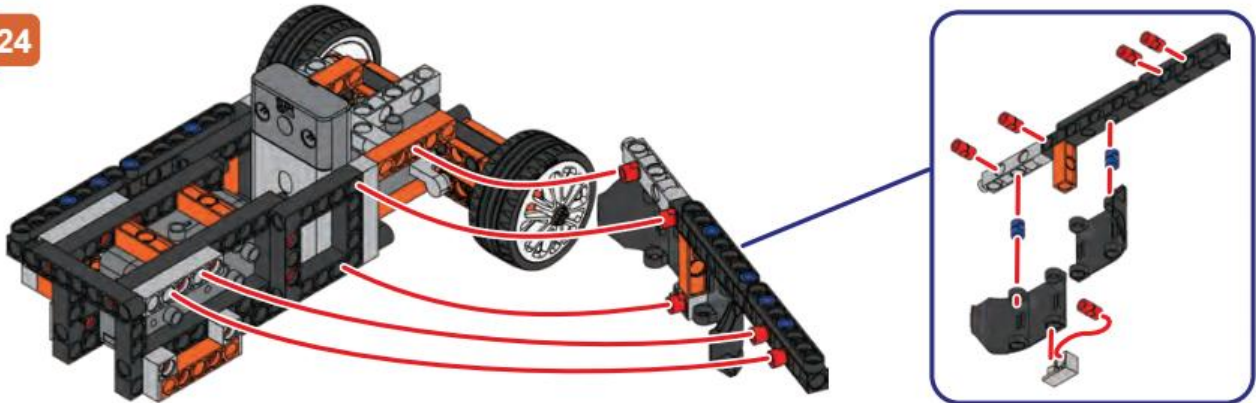

25

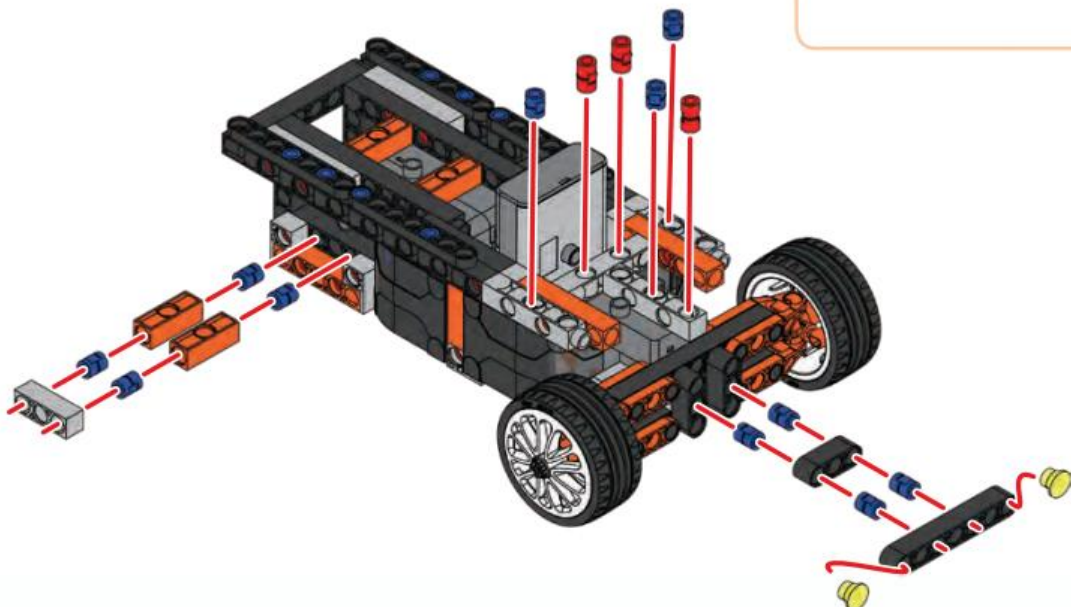





PICKUP TRUCK

Model 7 Pickup Truck

26

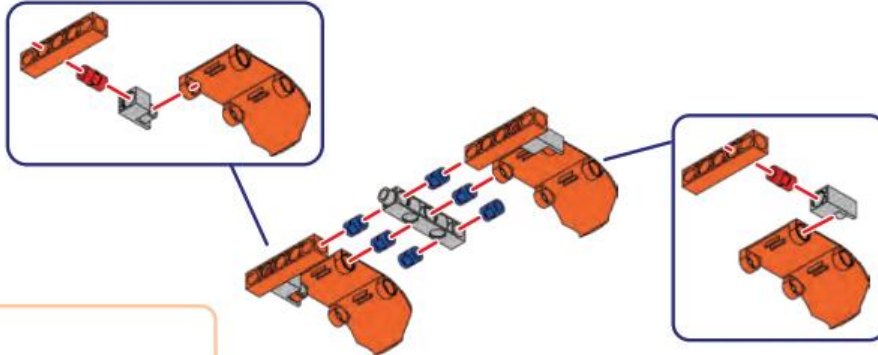

27

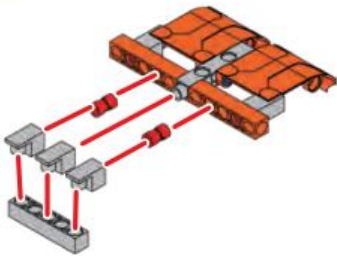

28

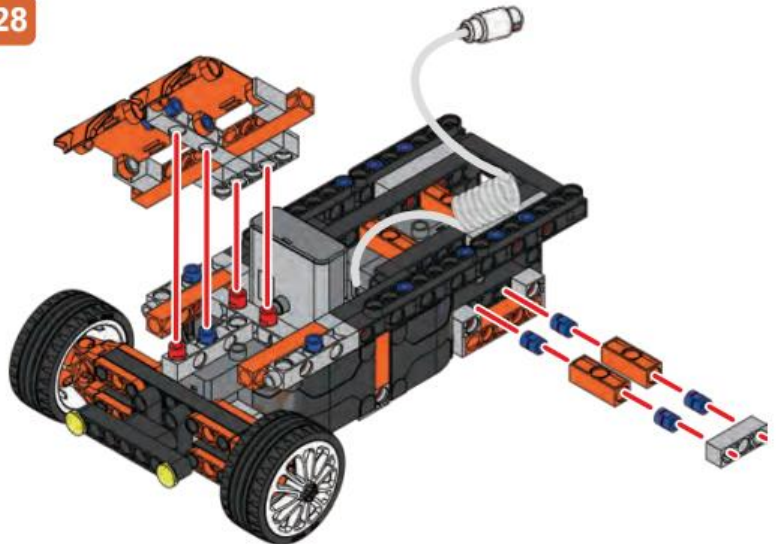

29



30

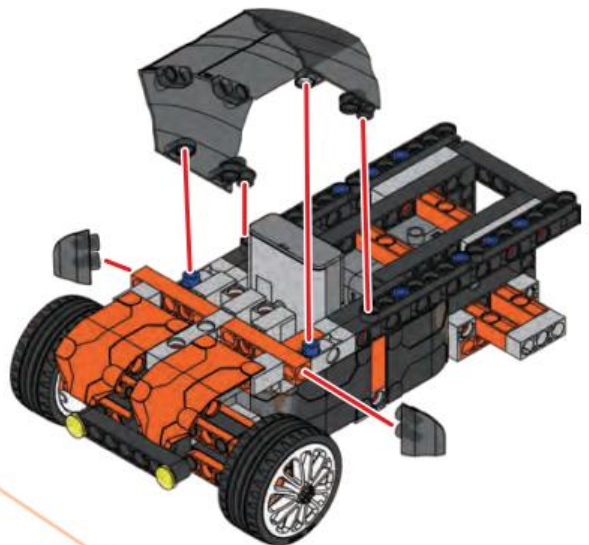

31





## Pickup Truck Model 7

32

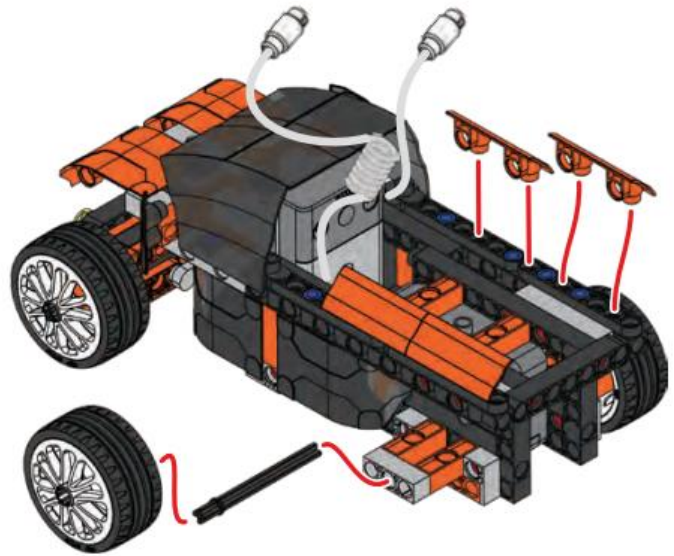

33

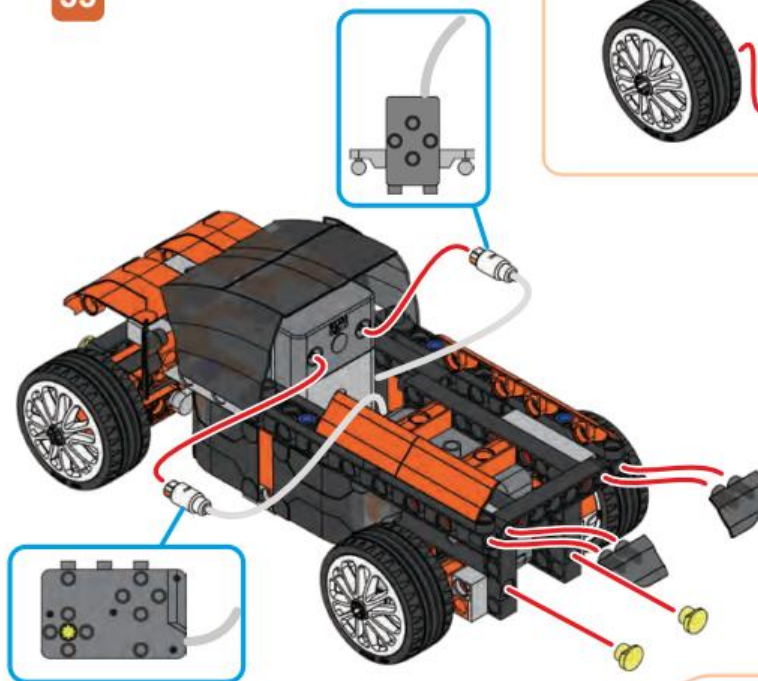

34

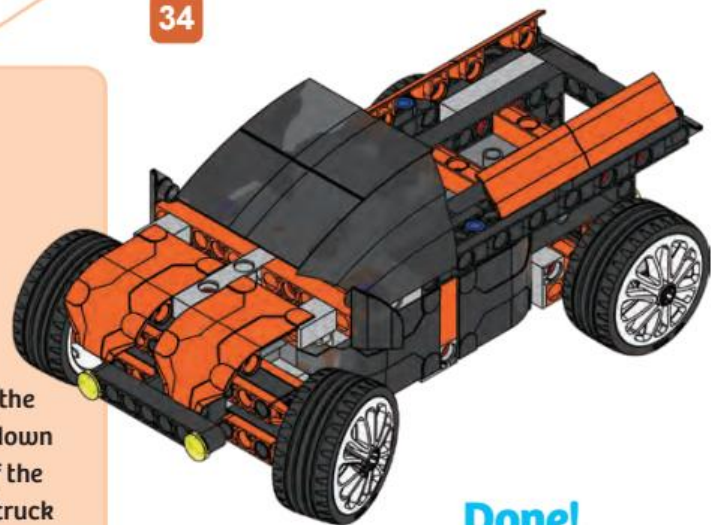

Done!

### EXPERIMENT 4

## Hauling Cargo

### HERE'S HOW

Measure a straight track about 5 feet long. Turn on the truck and time how long it takes to drive the truck down the track. Place a small, heavy object in the back of the truck and again time how long it takes to drive the truck down the length of the track. How did adding more weight to the truck affect the time?



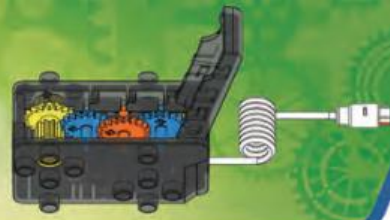

## TRUCK

## Model 8 Truck

### Parts Needed

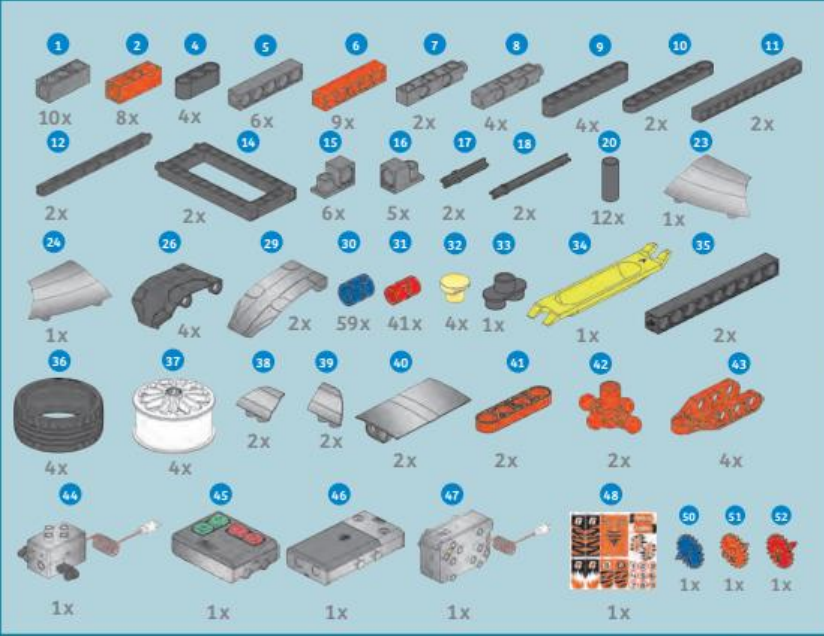

1 x2



2



3 x2

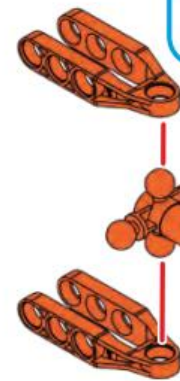
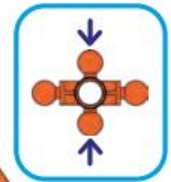

4

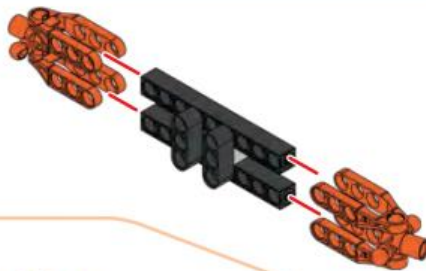

5

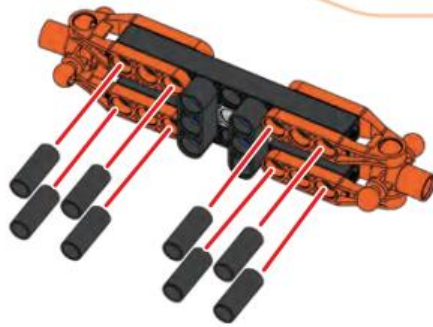

6

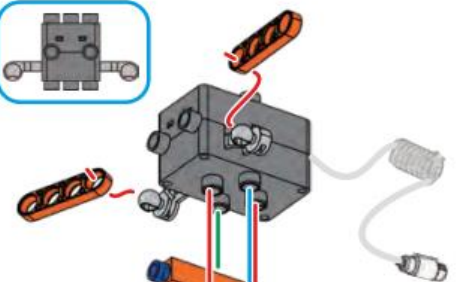
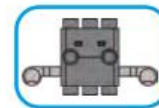

x3



7

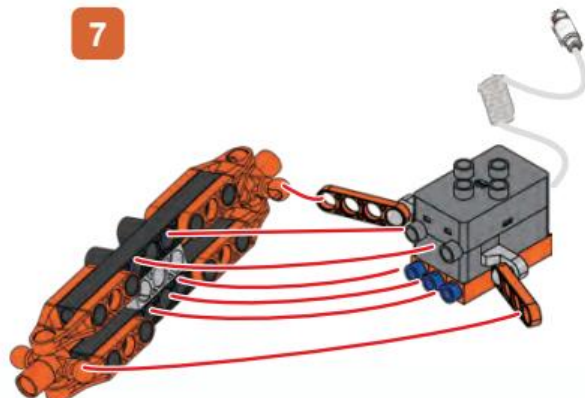

8 x4





## Truck Model 8

9



Medium  
Speed & Torque

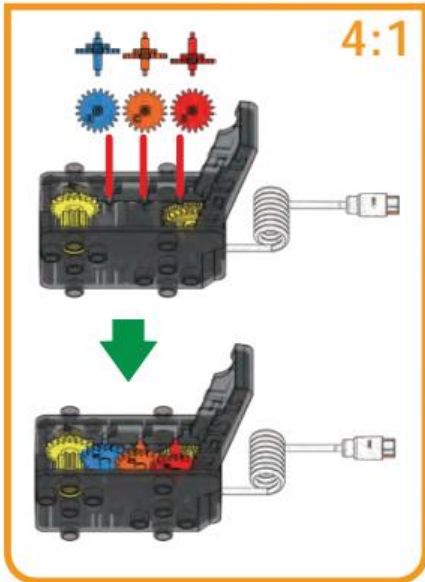

10

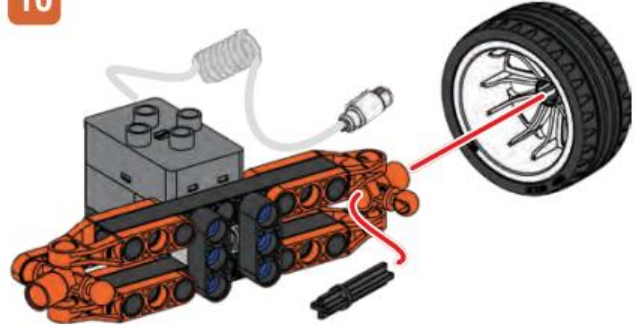

11

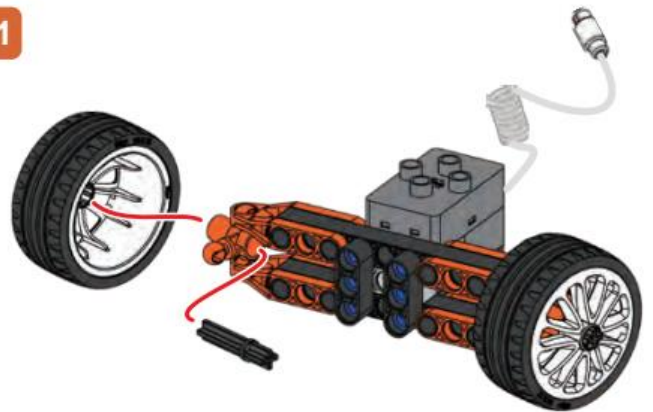

12

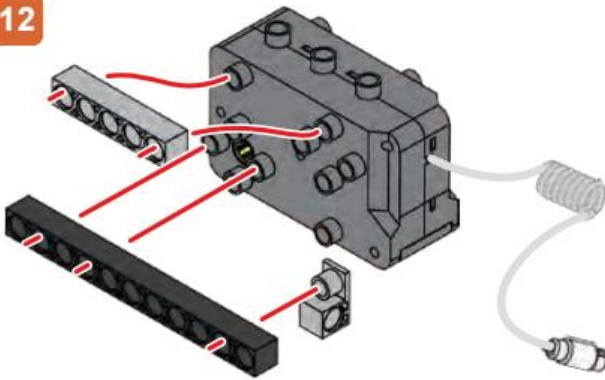

13

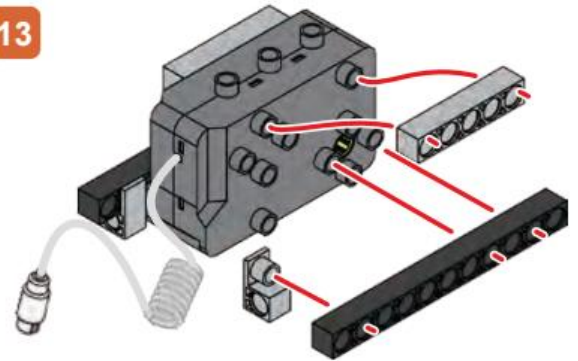

14

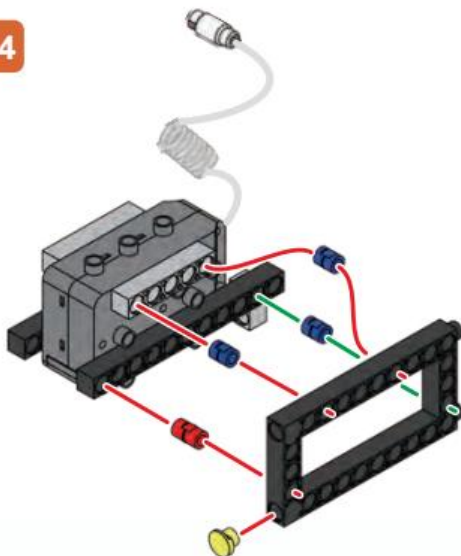

15

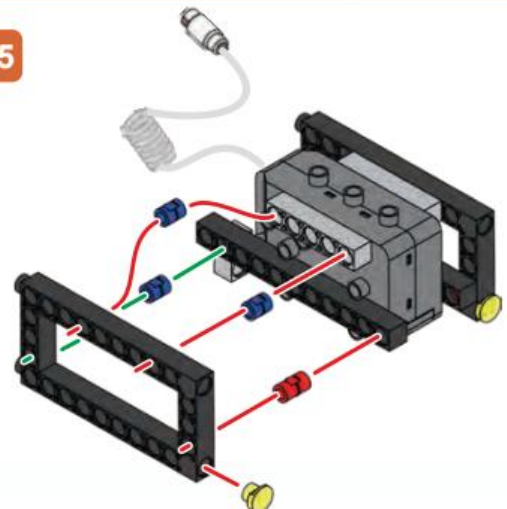



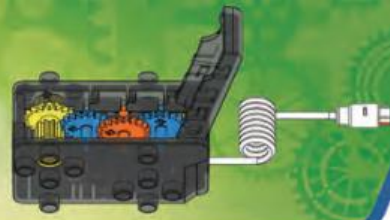

TRUCK

Model 8 Truck

16

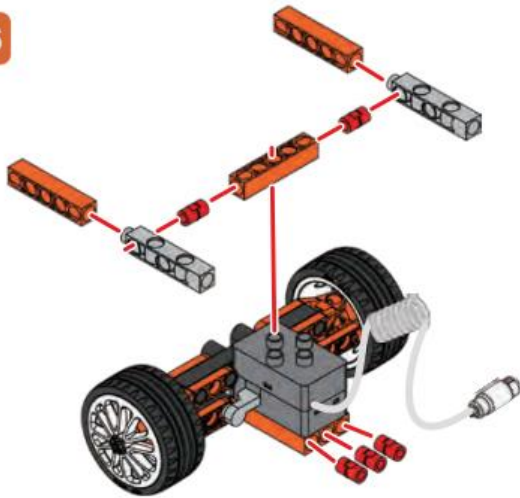

17

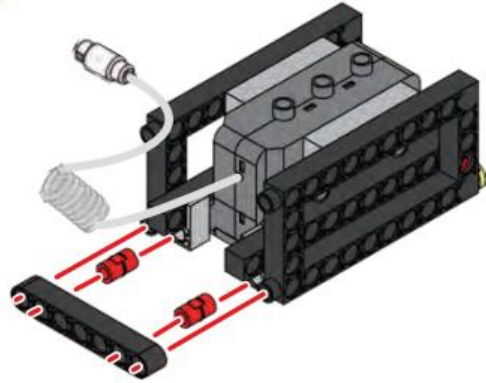

18

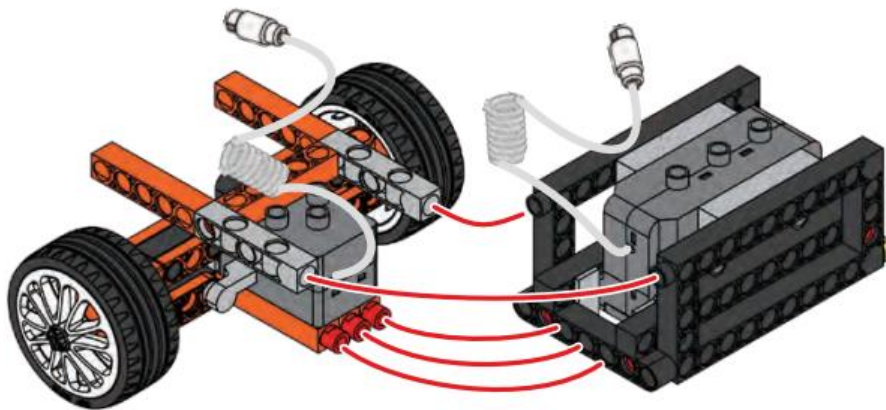

19

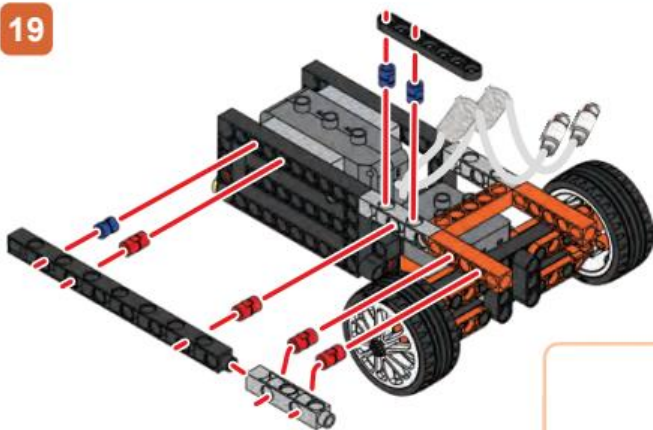

20

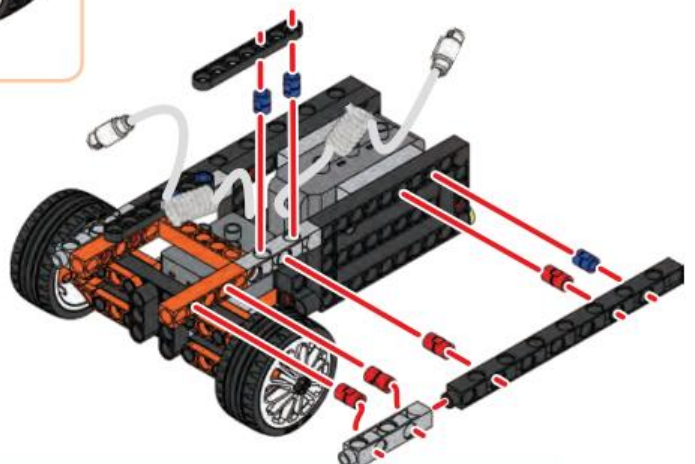

21 x2

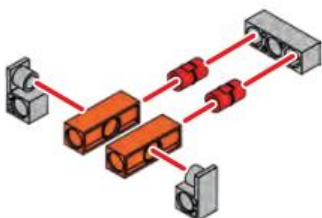



## Truck Model 8

22



23

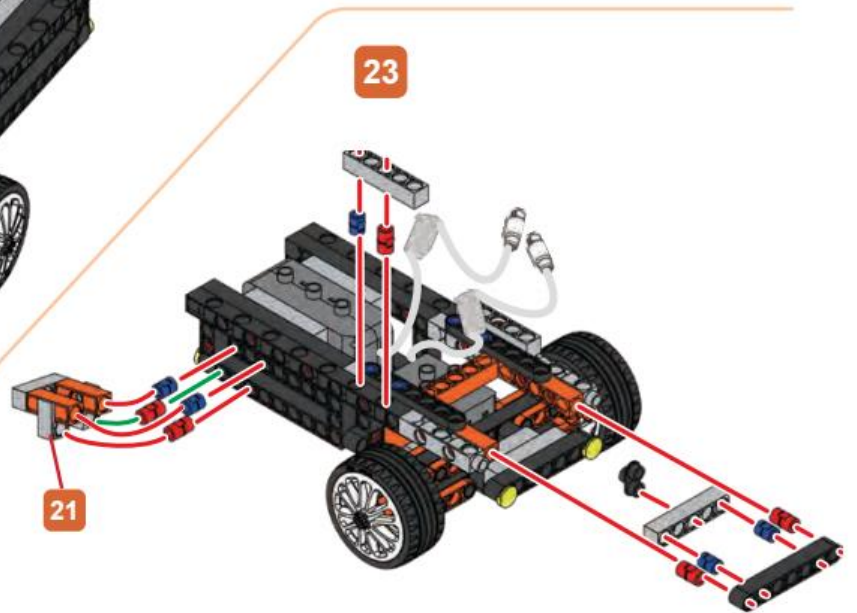

21

25

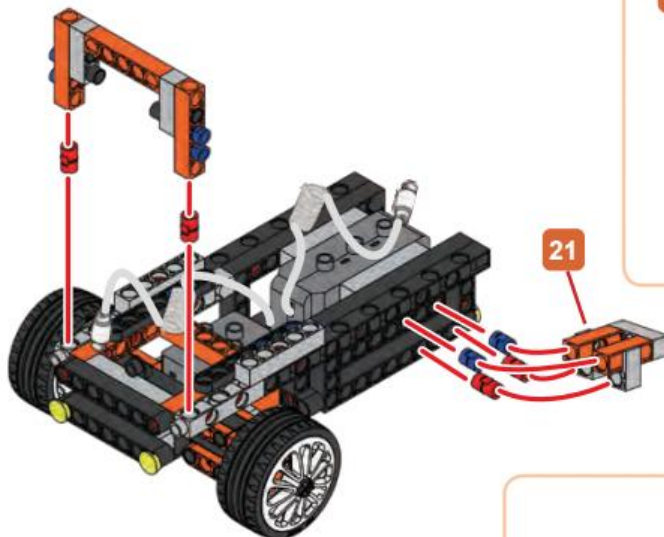

21

24

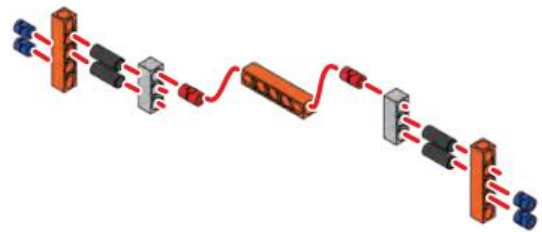

26

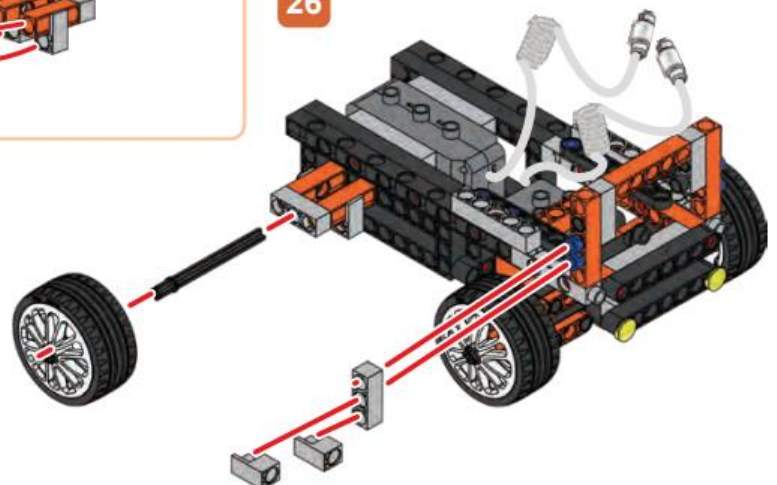





27

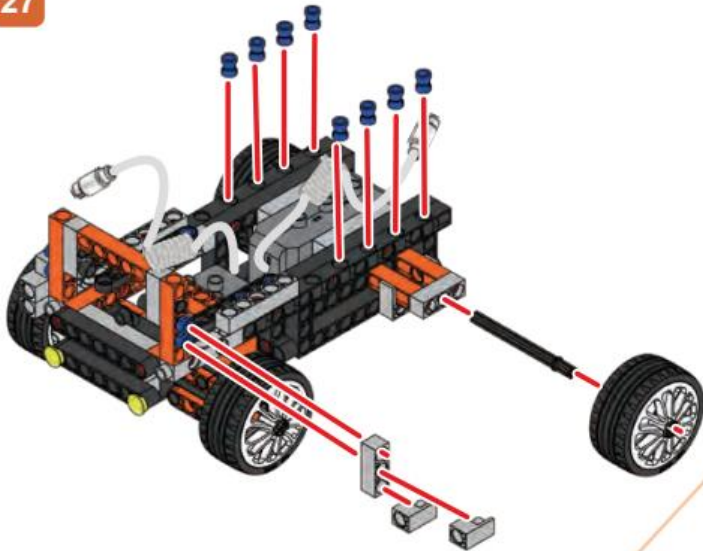

28

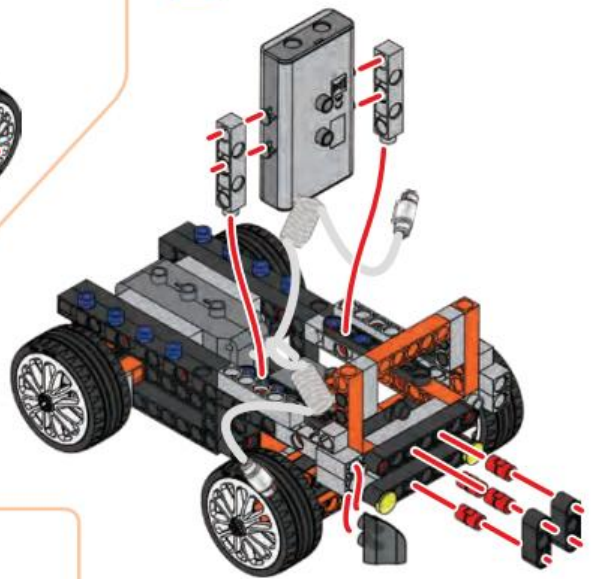

29

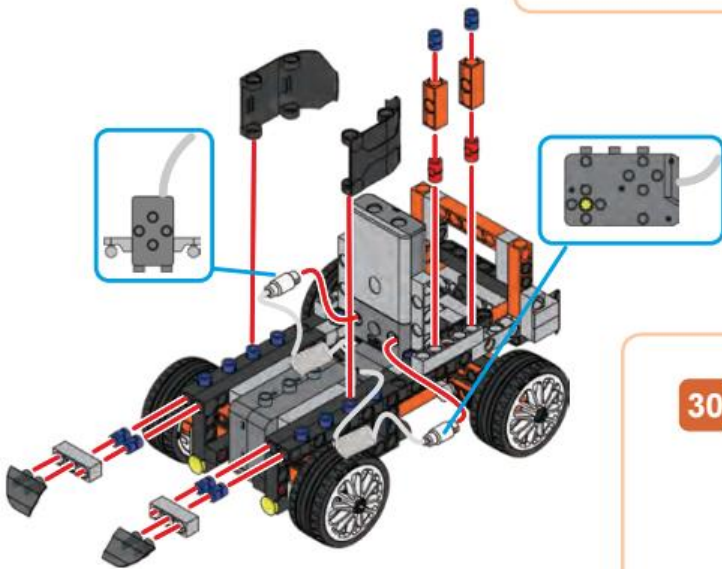

30

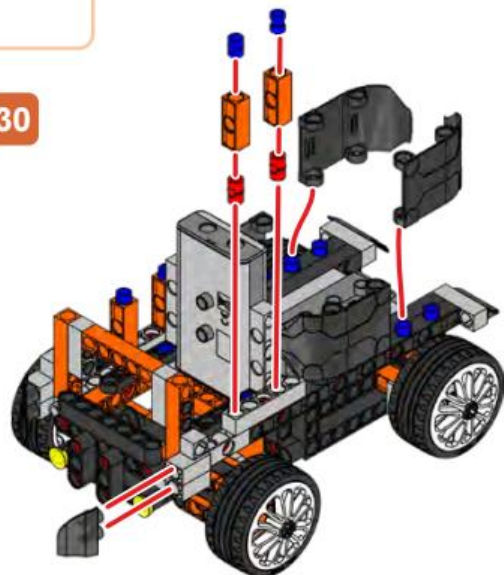



## Truck Model 8

31

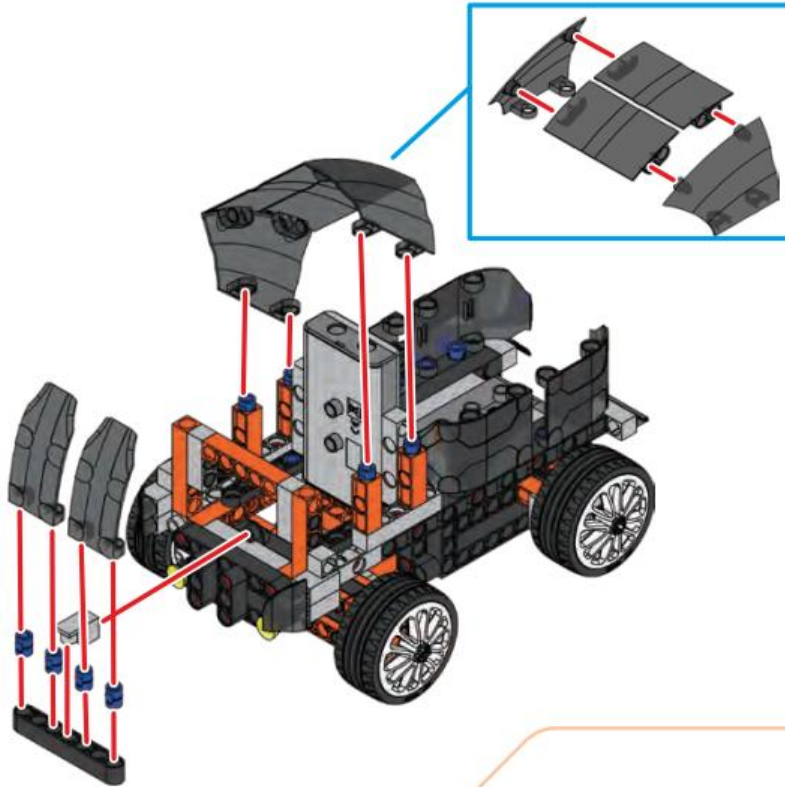

32

Done!

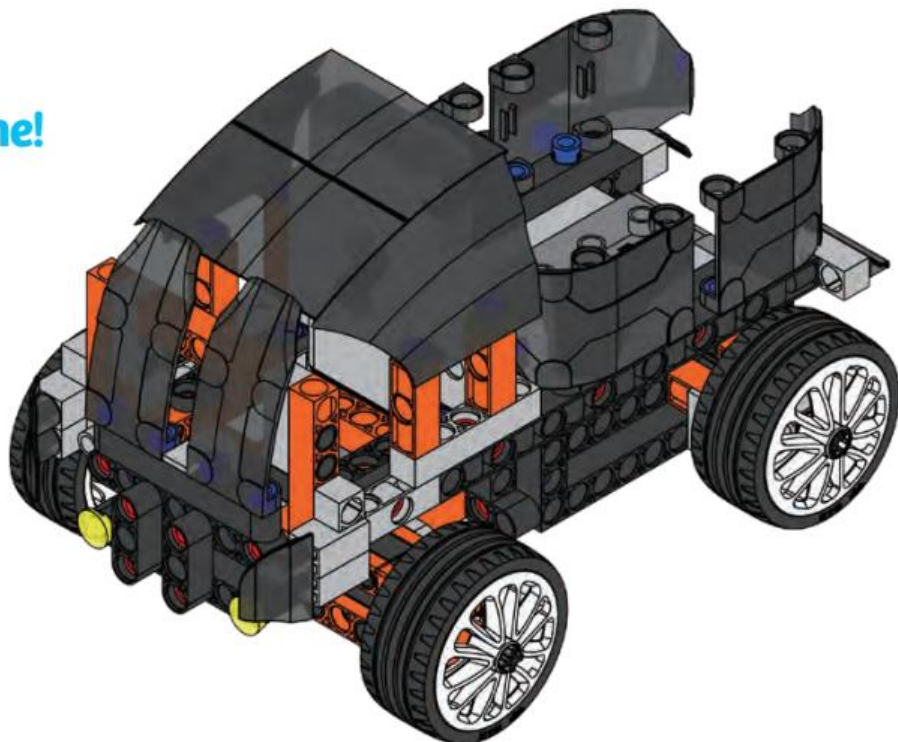



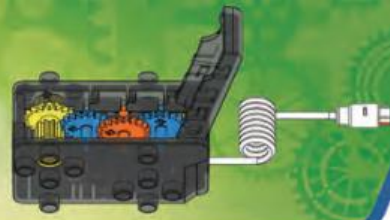

## BUGGY

## Model 9 Buggy

### Parts Needed

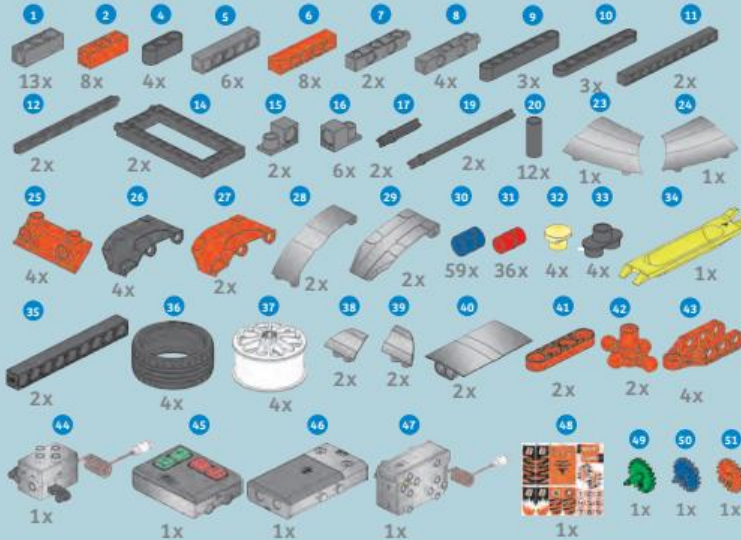

1 x2



2

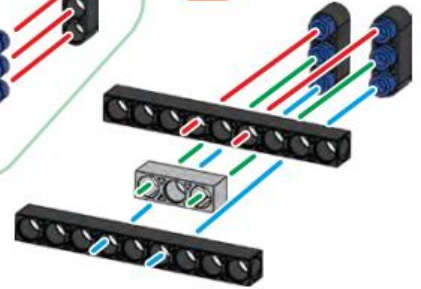

5

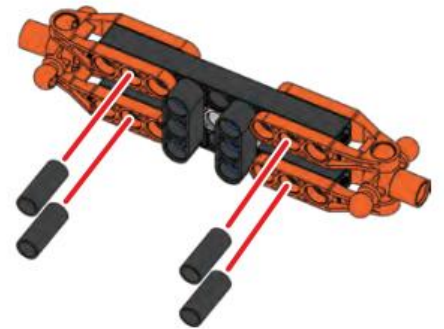

3 x2

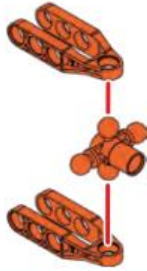

4

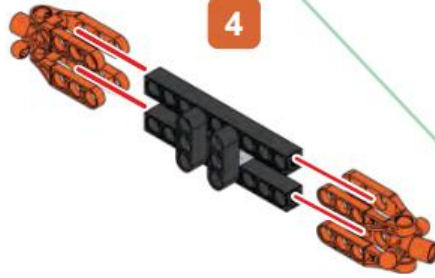

6

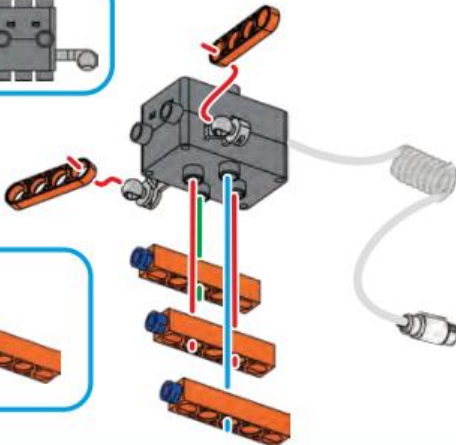
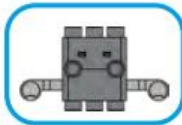

x3

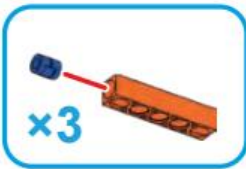

7

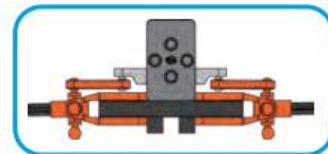

8 x4





## Buggy Model 9

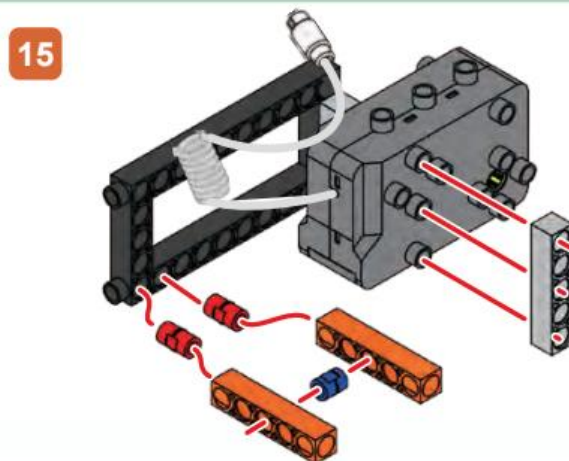
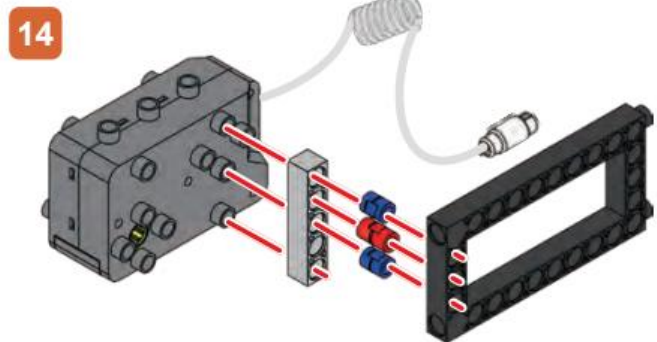
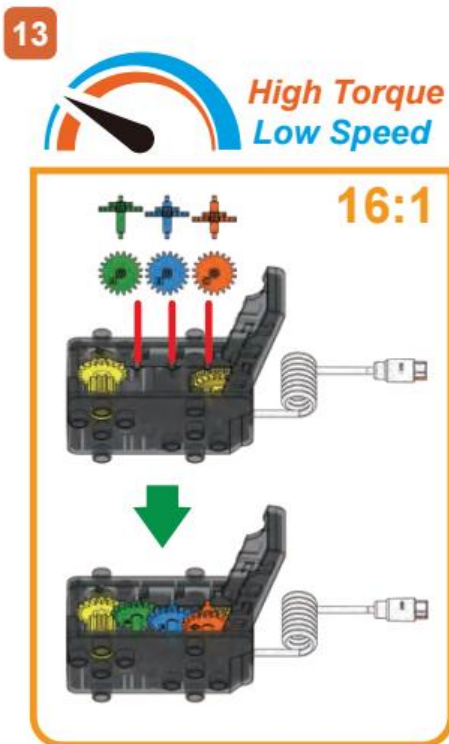
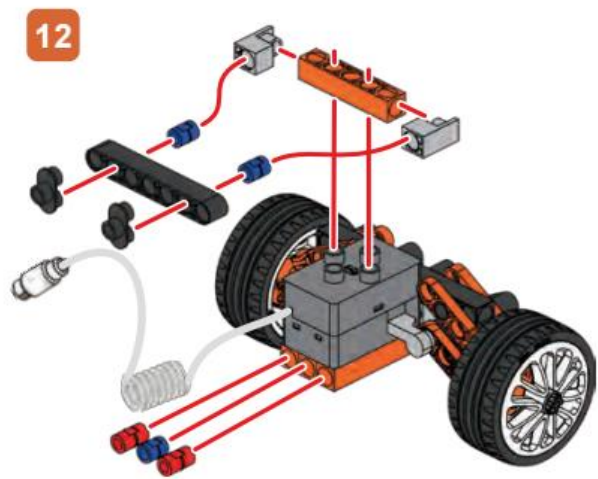
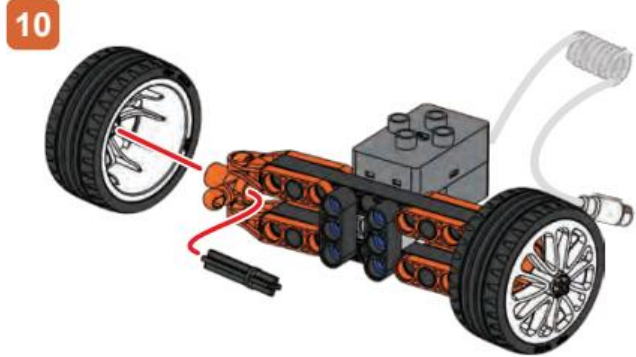
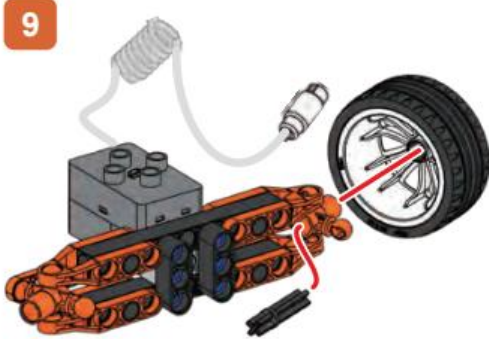



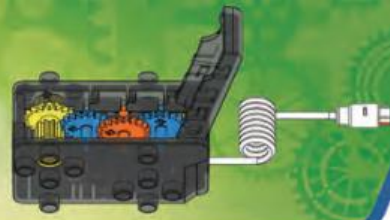

BUGGY

Model 9 Buggy

16

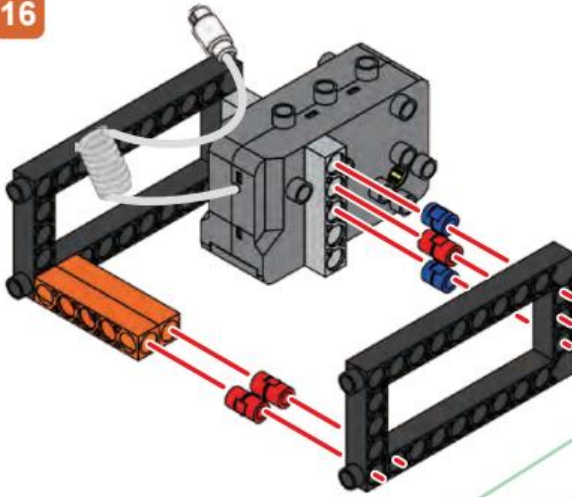

17

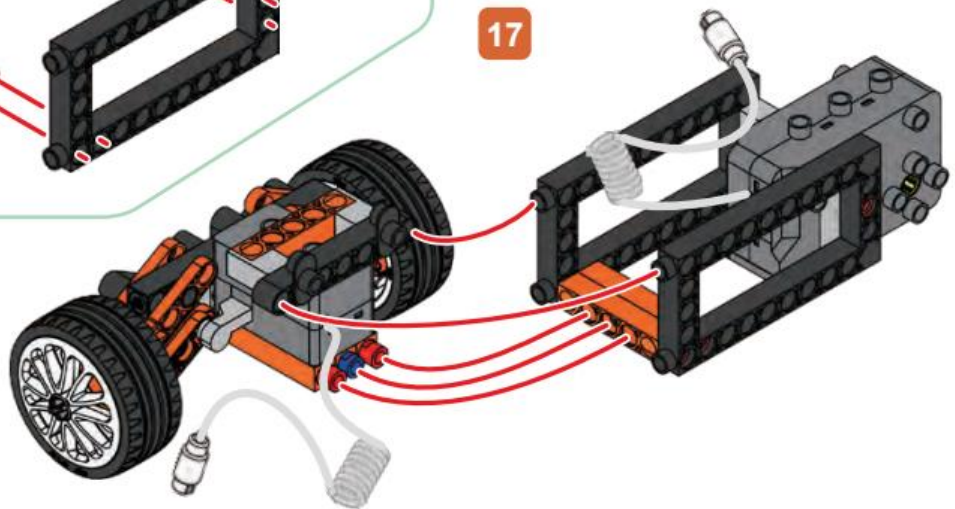

18

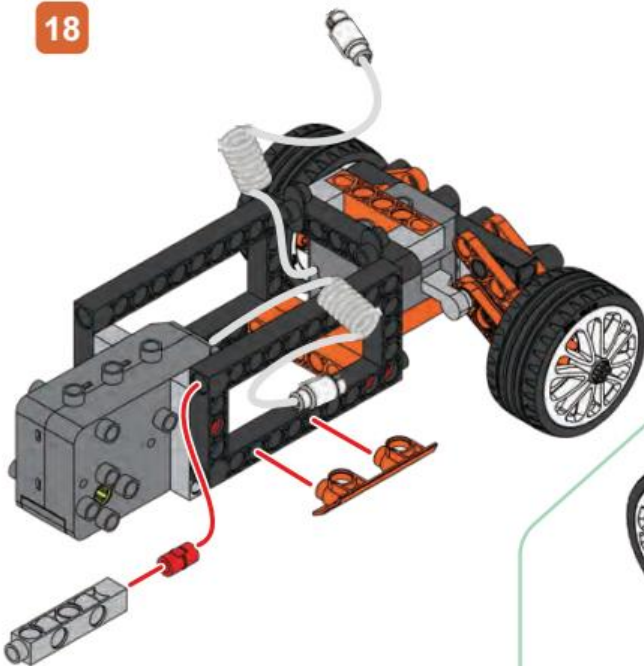

19

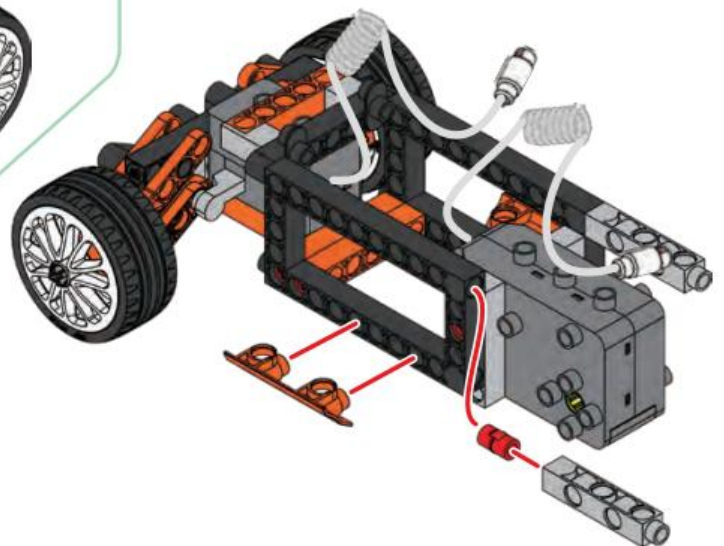

## Buggy Model 9

20 x2

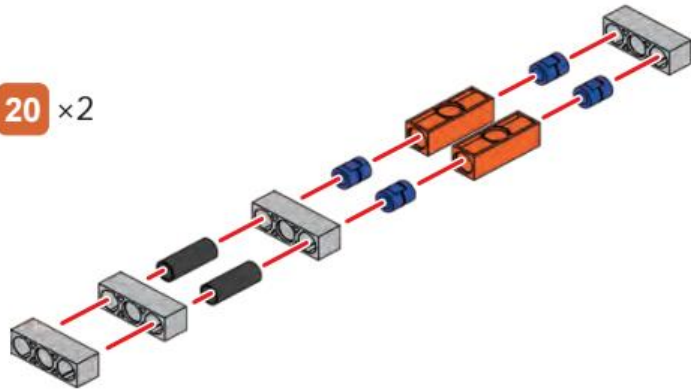

21

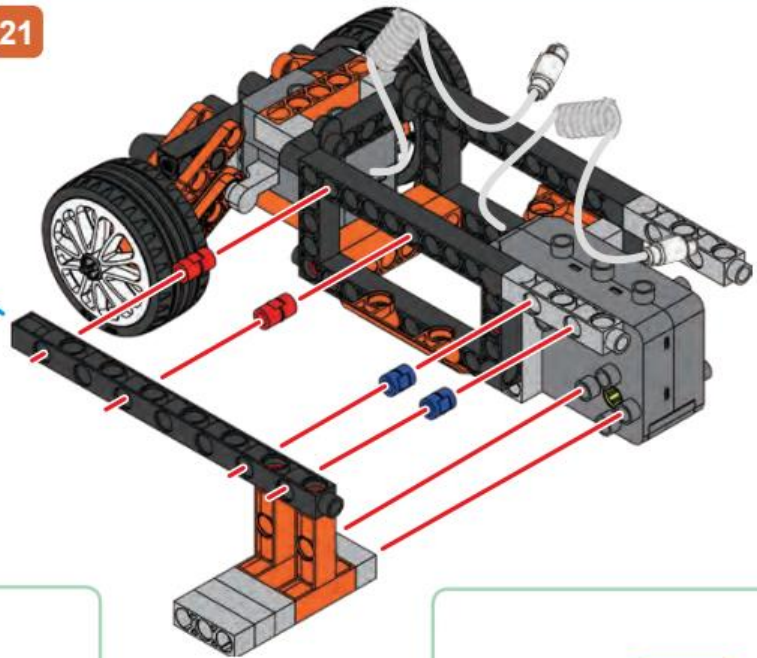

22

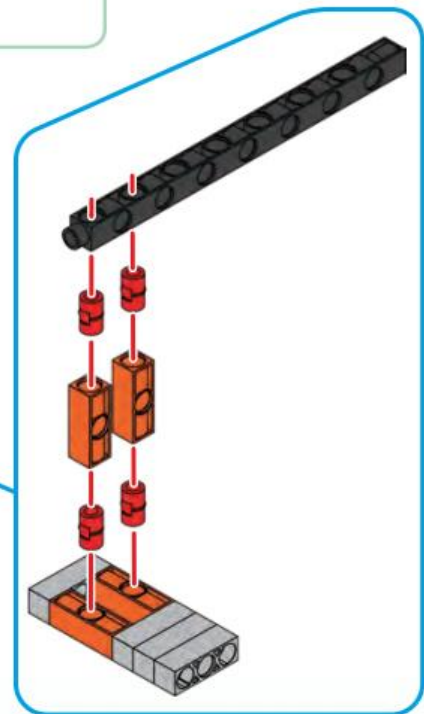
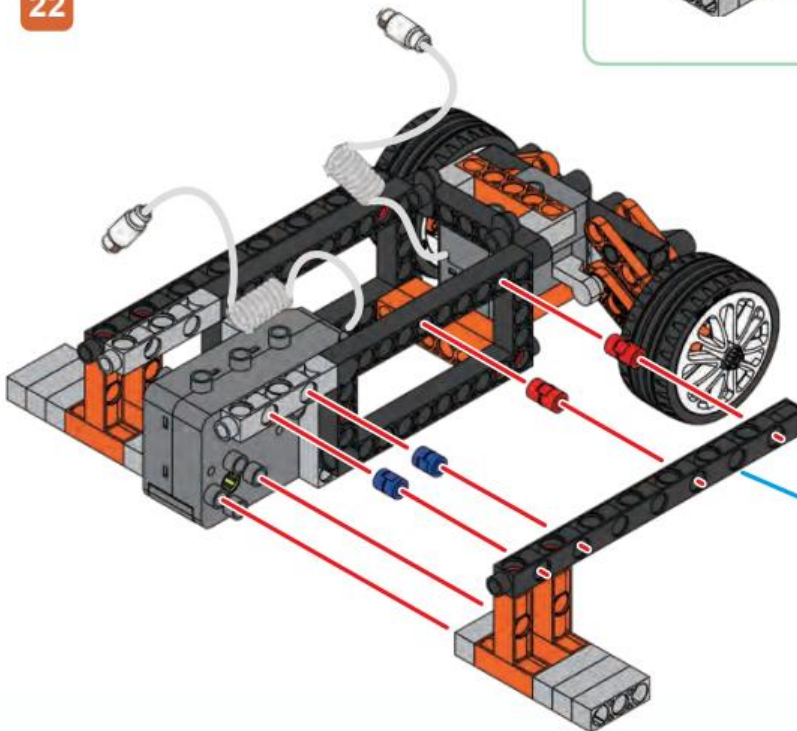



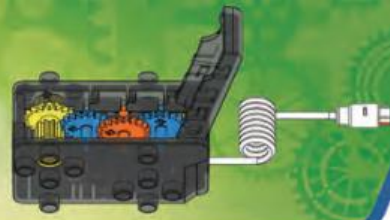

BUGGY

Model 9 Buggy

23

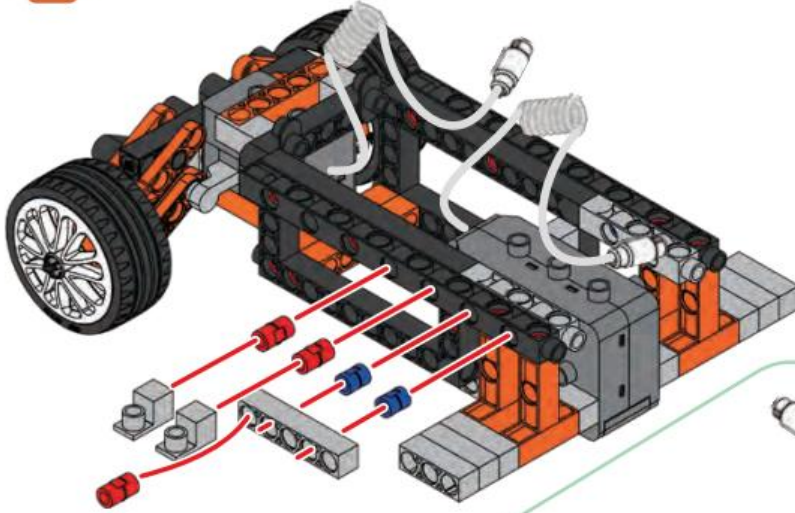

24

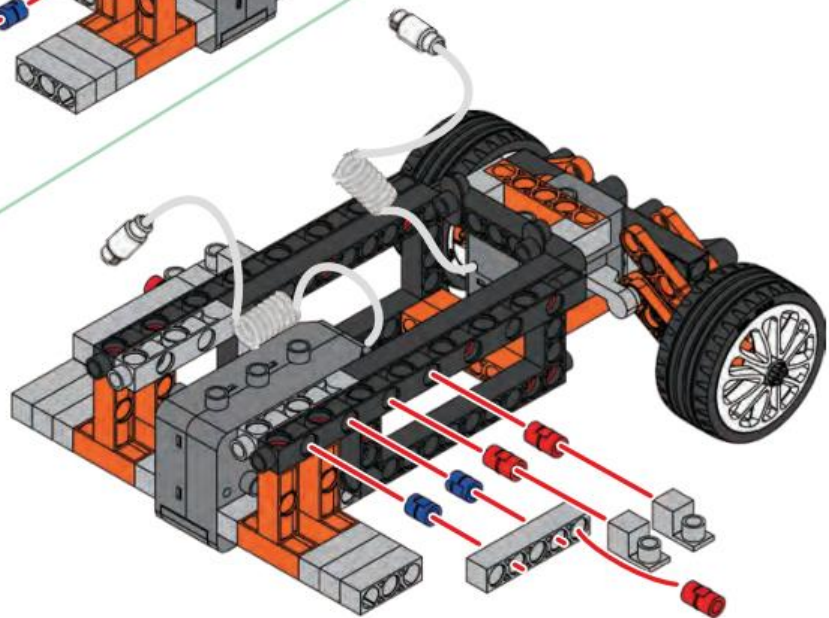

25

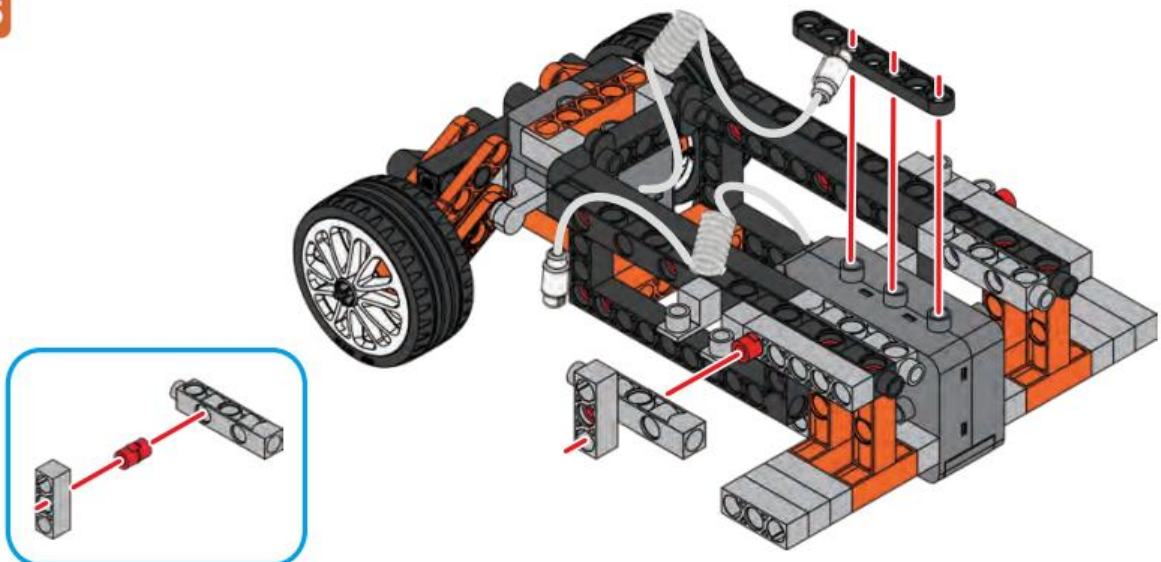



## Buggy Model 9

26

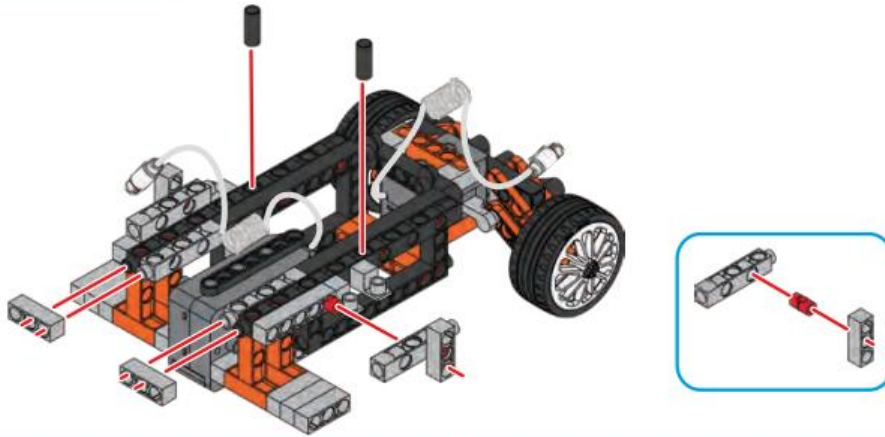

27

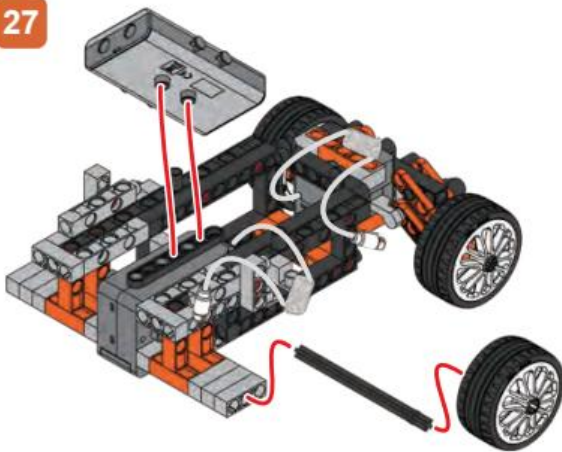

28

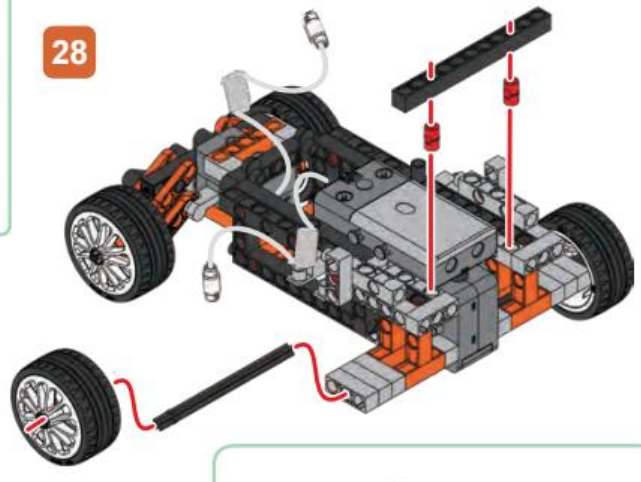

29

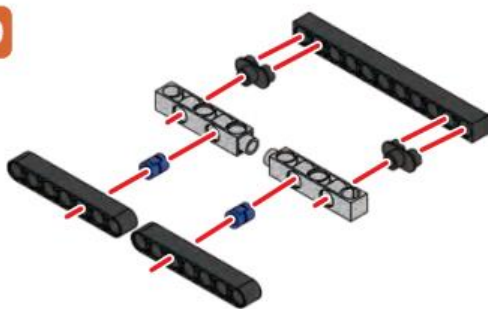

30

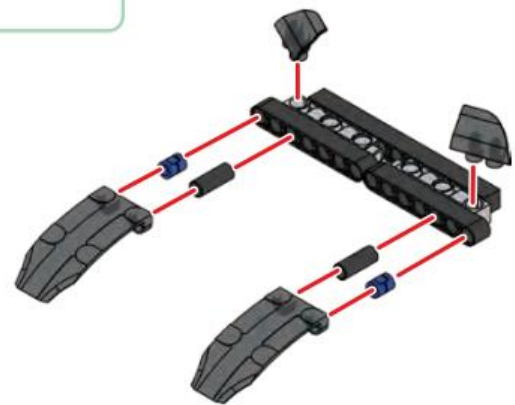

31

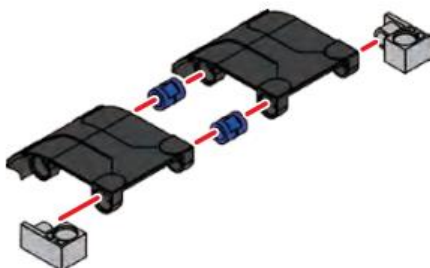

32

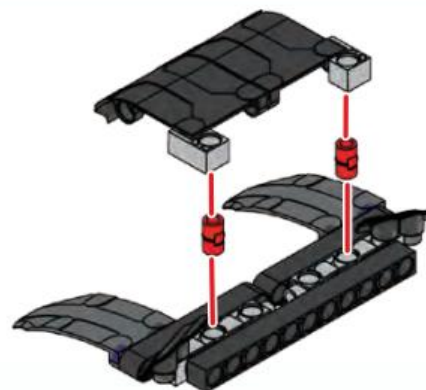





Model 9 Buggy

33

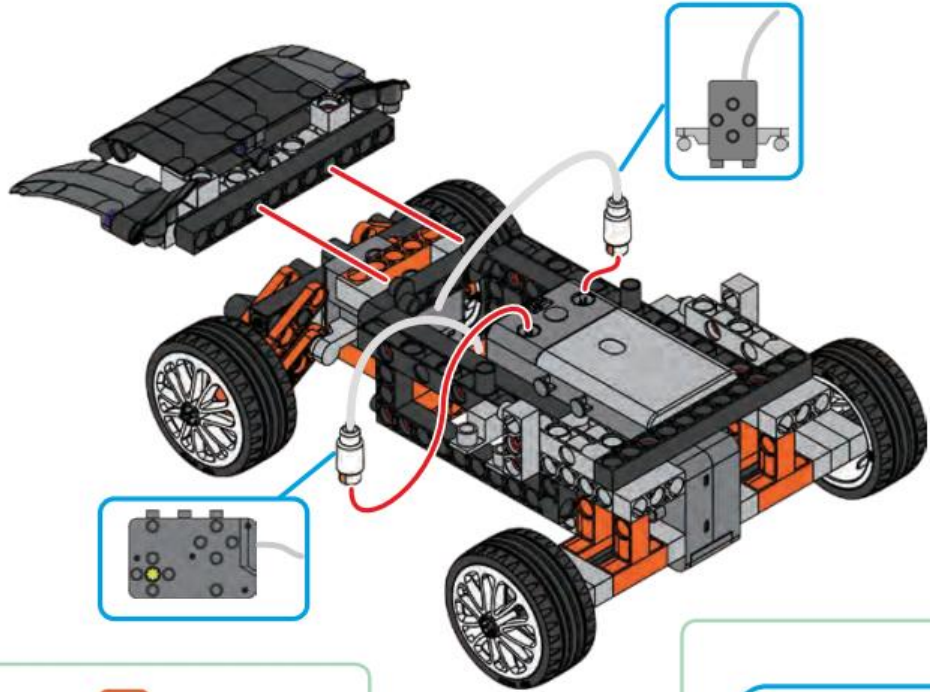

34

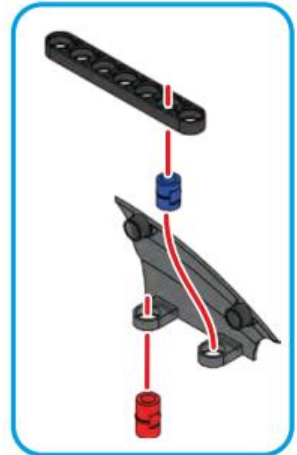
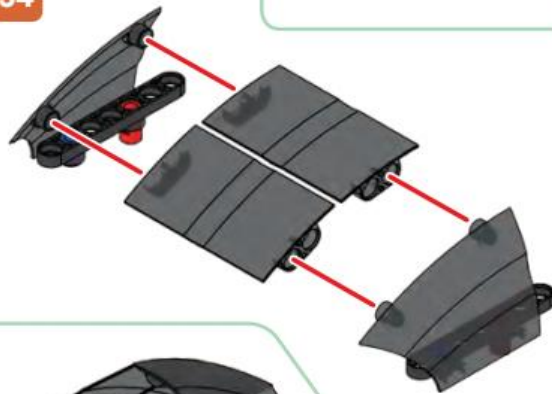
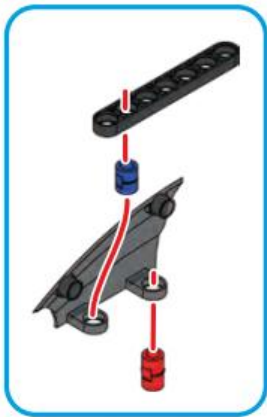

35

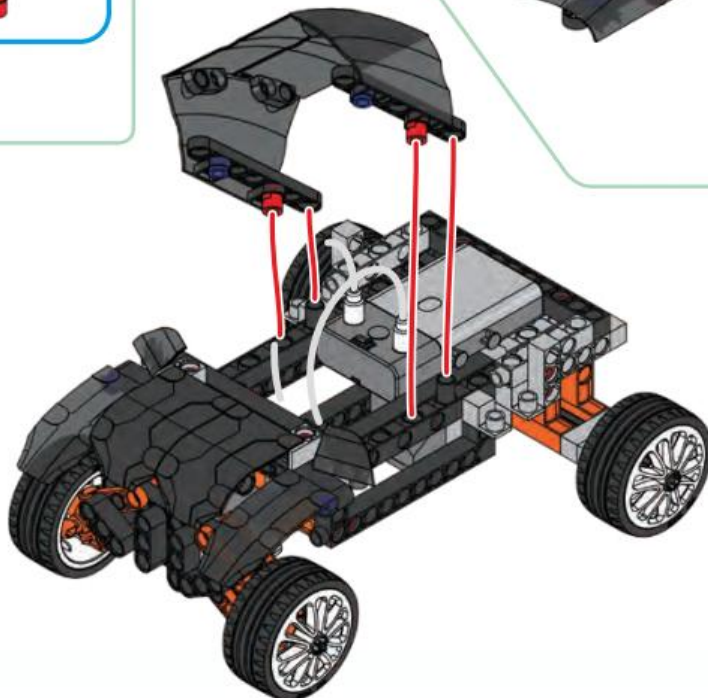



## Buggy Model 9

36

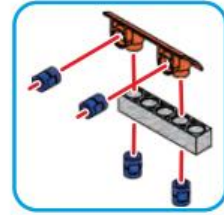
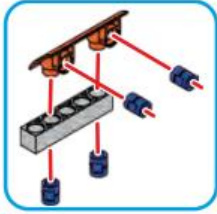

37

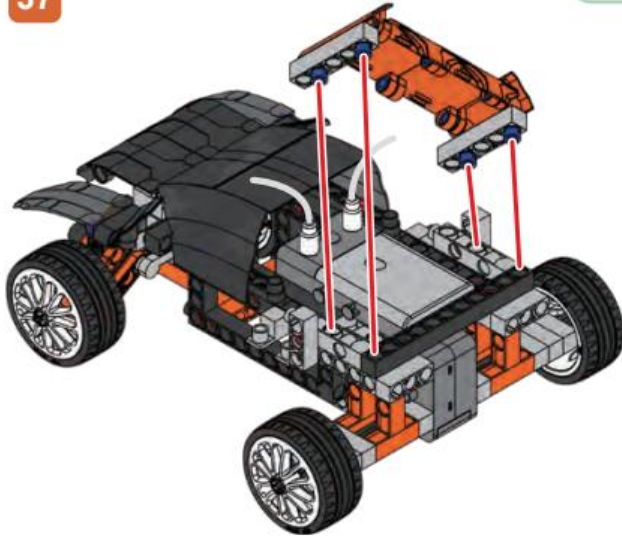

38

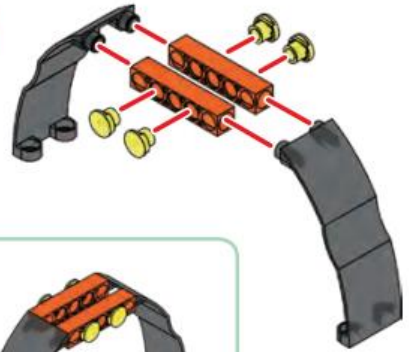

39



40

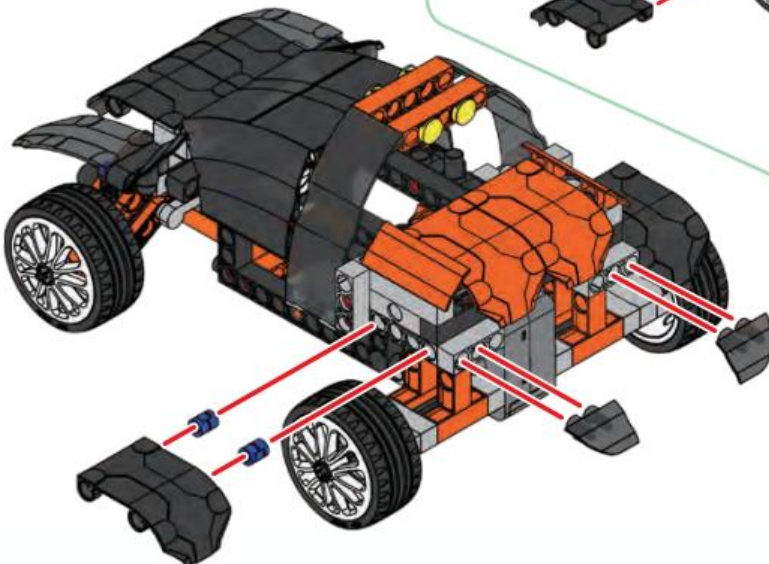



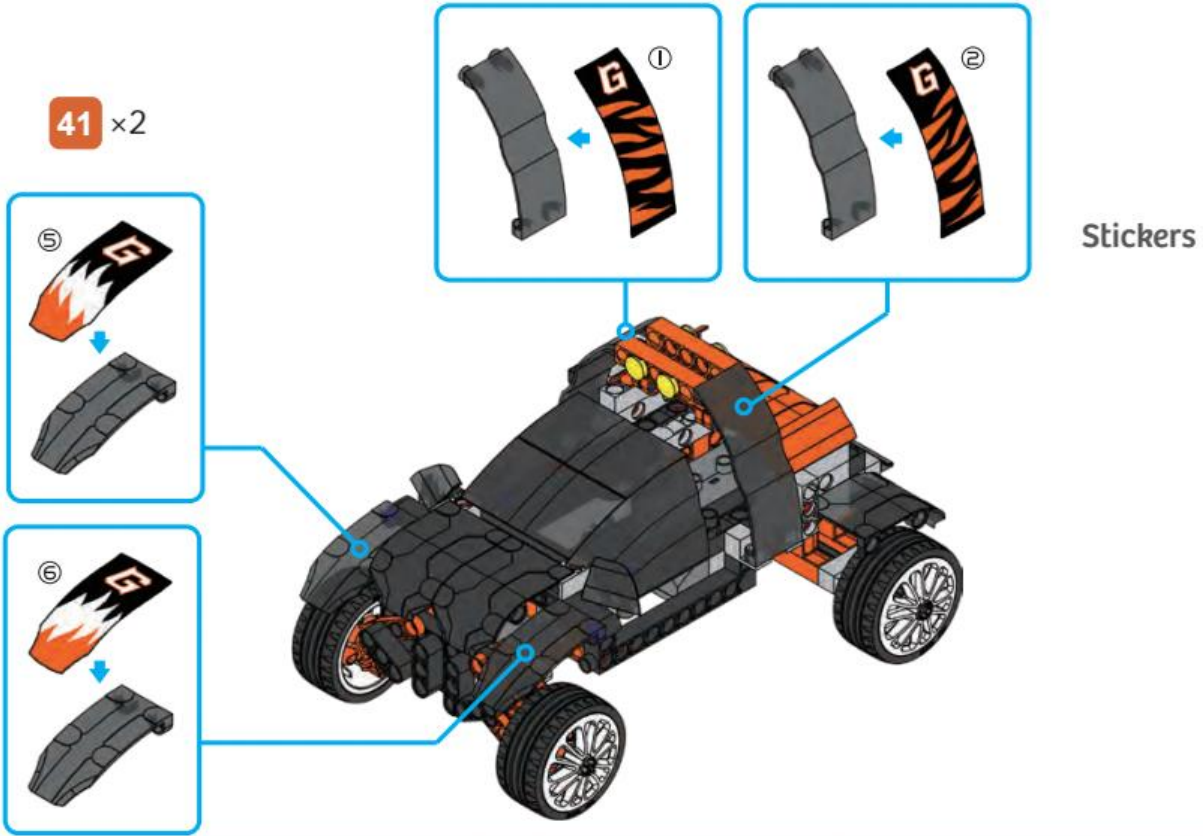

**42**

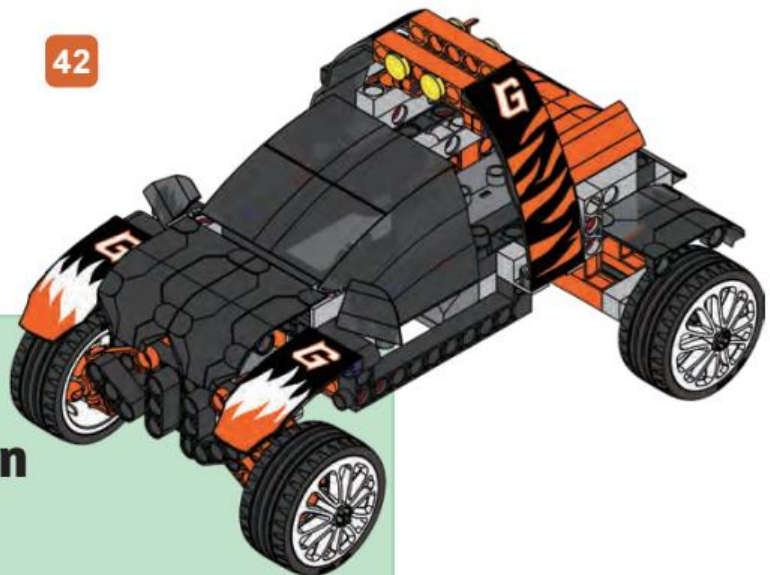

### EXPERIMENT 5

## Climbing a Mountain

### HERE'S HOW

This buggy is designed to drive up steep hills. Set up an incline using materials like books and cardboard. Vary the angle of the incline and time how long it takes the car to drive up the different inclines.

Keep the incline at the same angle, but change the gear ratio in the adjustable gearbox. What happens to the speed of the car?



## Electric Car Model 10

### Parts Needed



1 x2

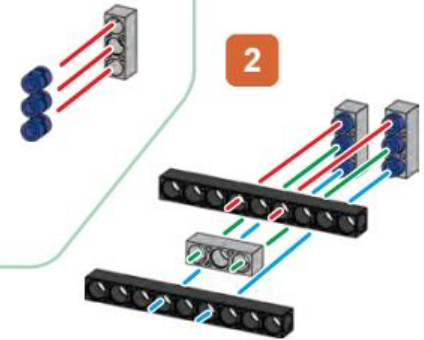

3 x2



4

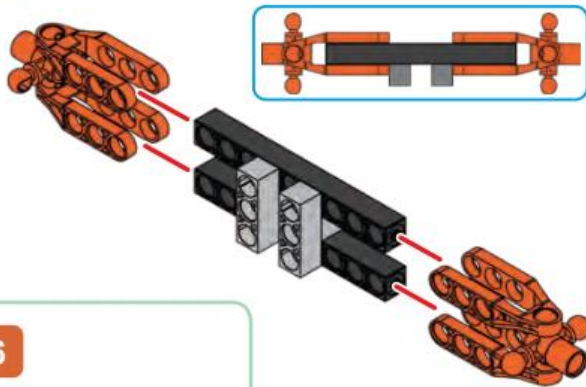

5

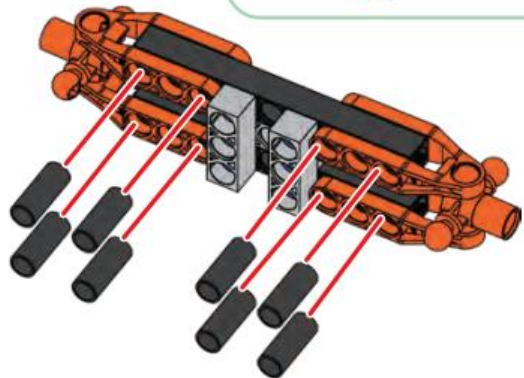

6

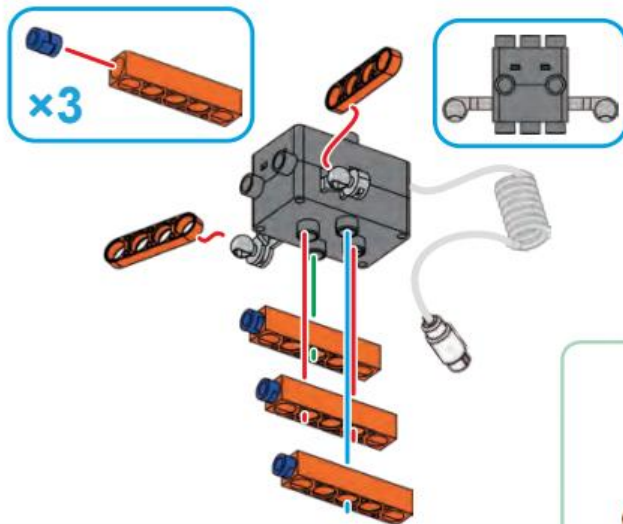

7

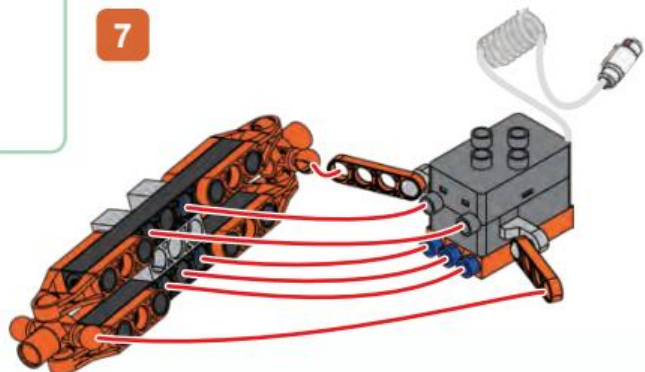





8 x4



9

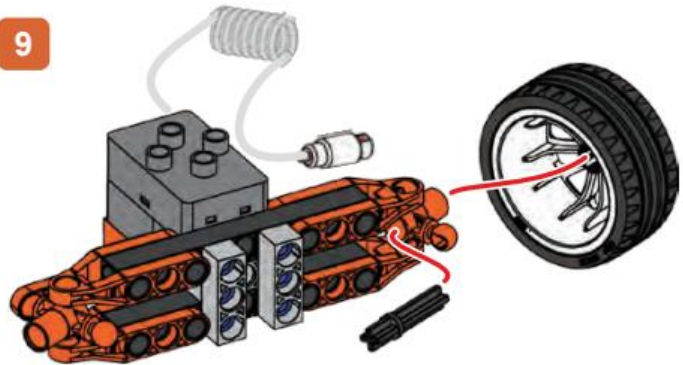

10

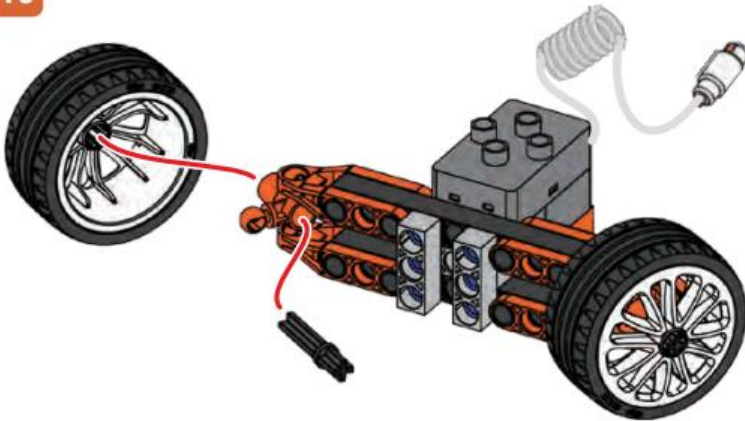

11



Medium  
Speed & Torque

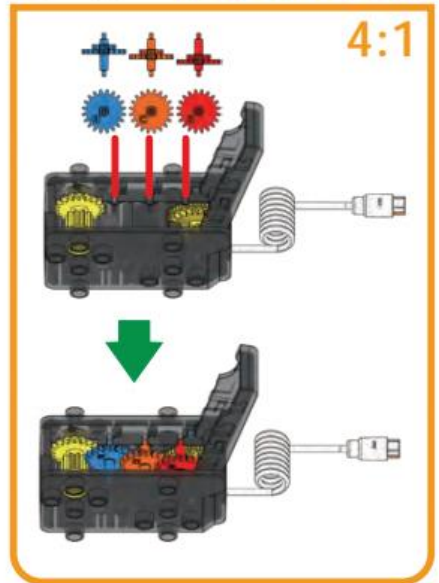

12

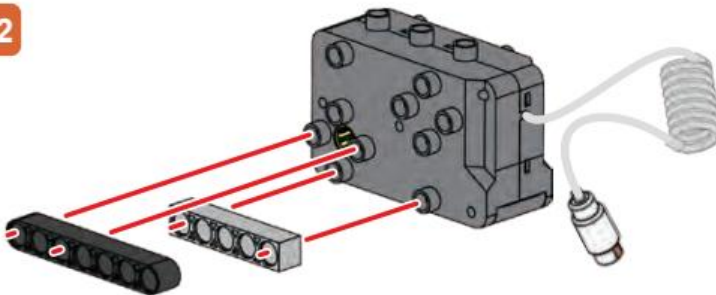

13

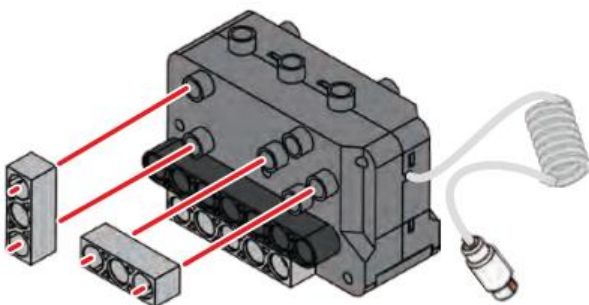

14

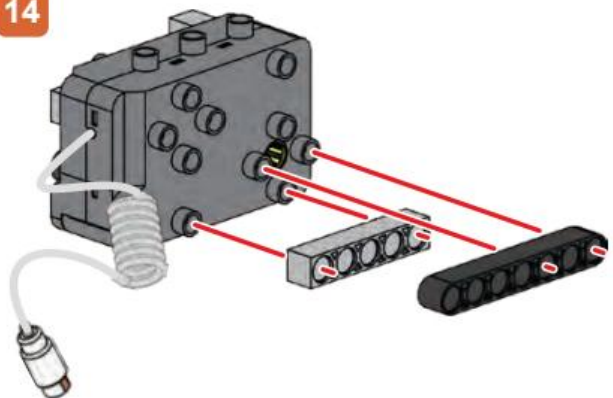



## Electric Car Model 10

15

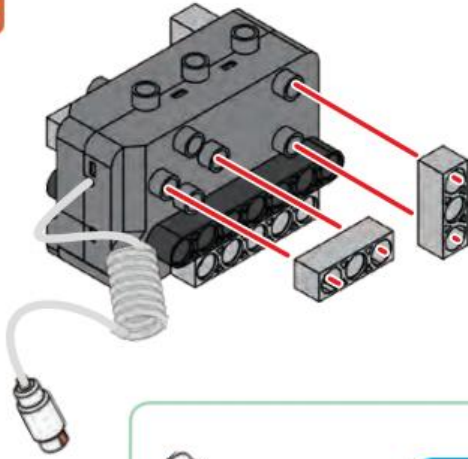

16 x2

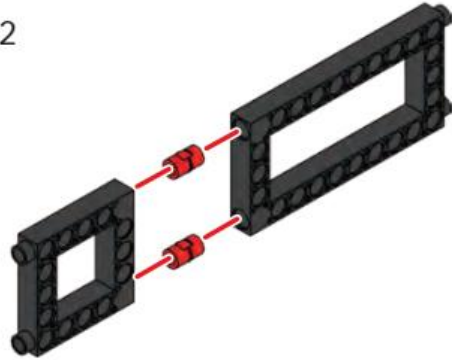

17

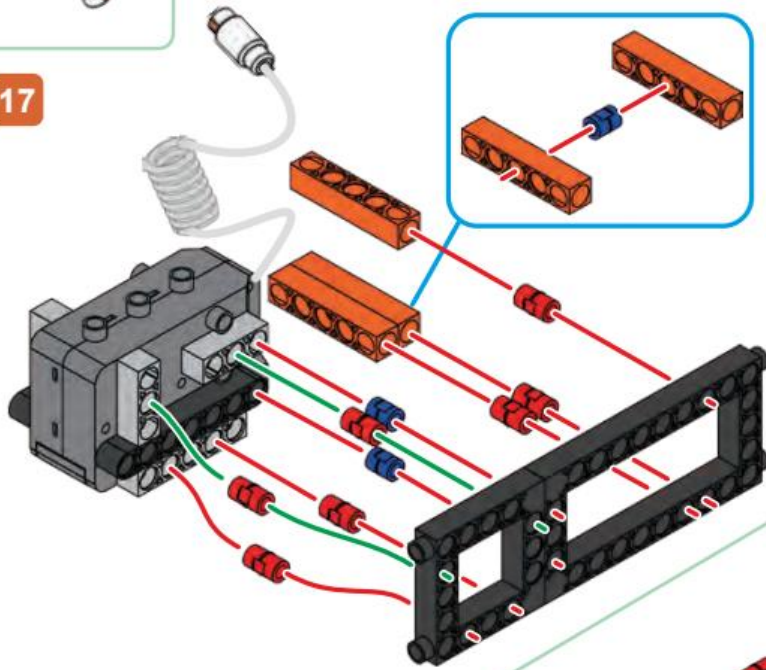

18

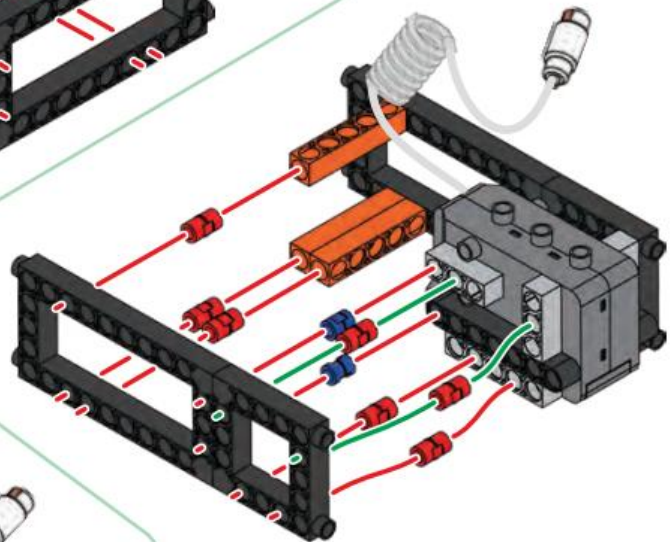

19







## ELECTRIC CAR

## Model 10 Electric Car

20



21

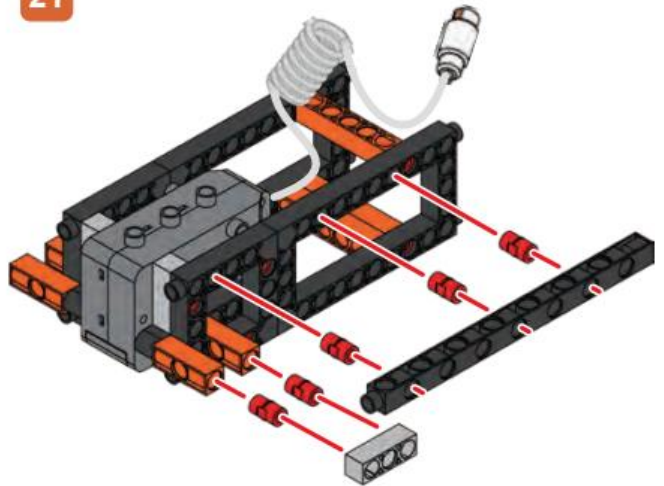

22

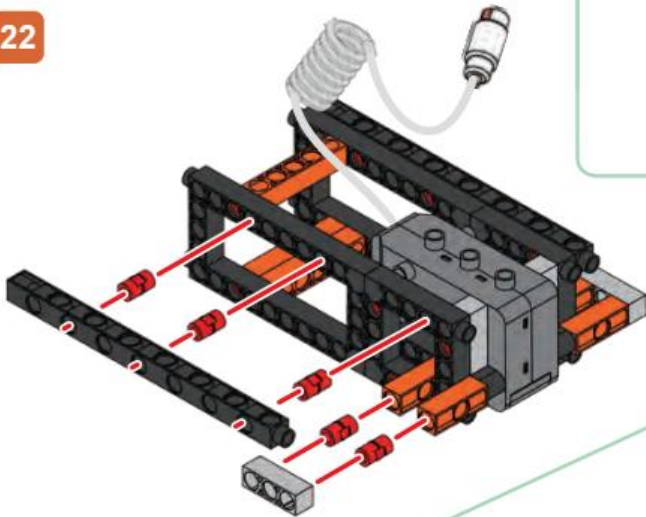

23

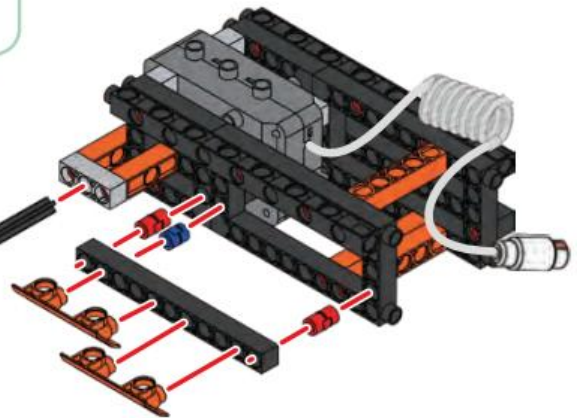

24

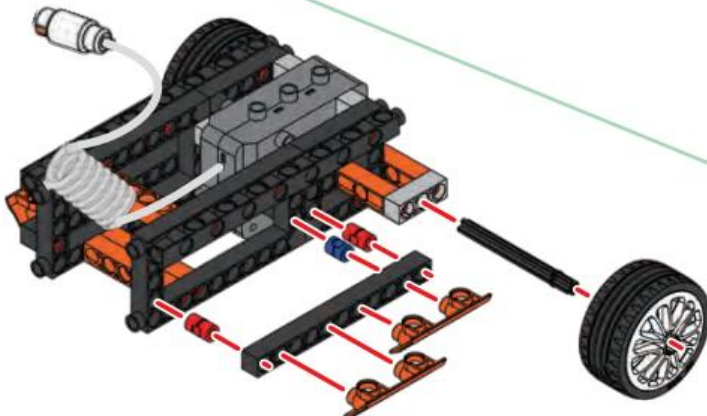



## Electric Car Model 10

25

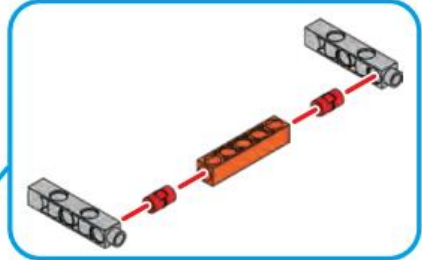
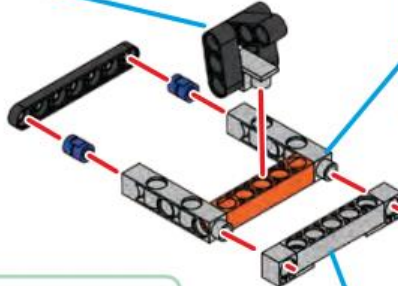
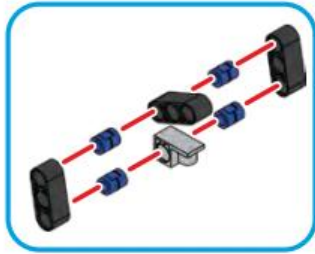

26

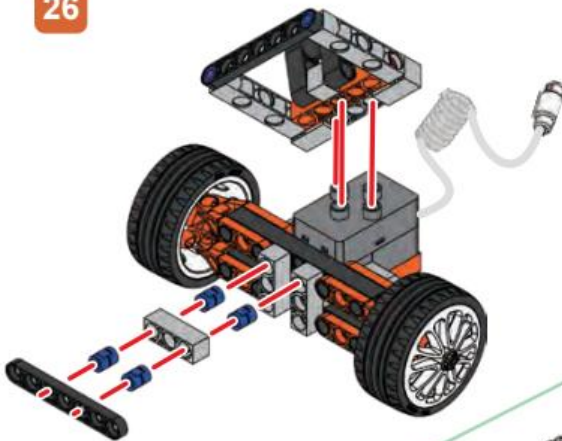

27

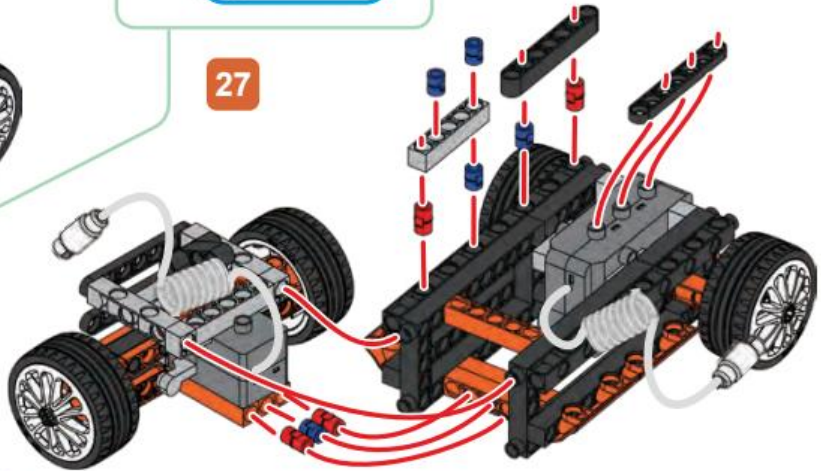

28

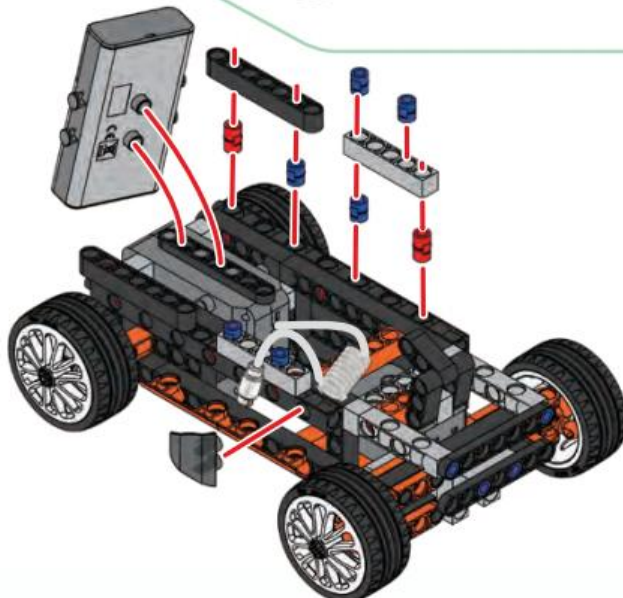



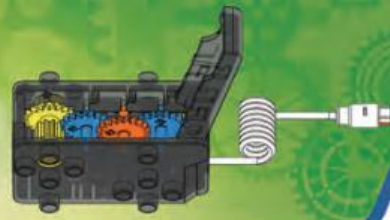

ELECTRIC CAR

Model 10 Electric Car

29

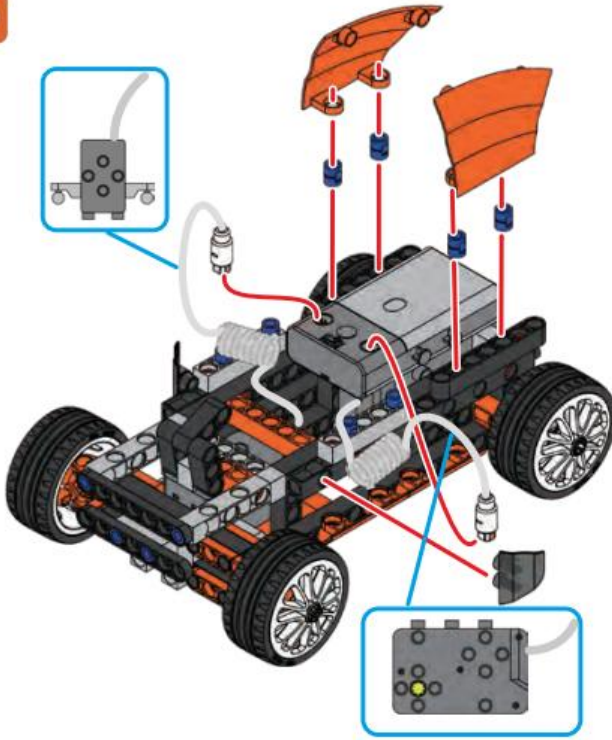

30

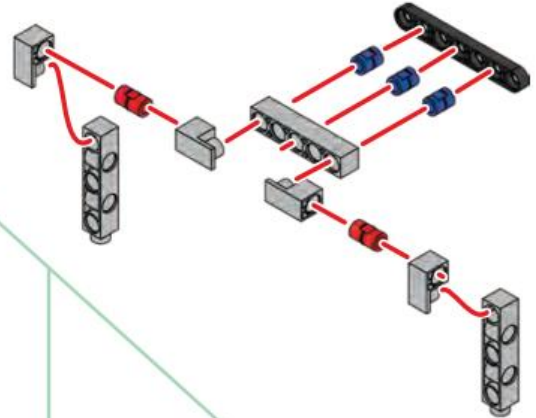

31

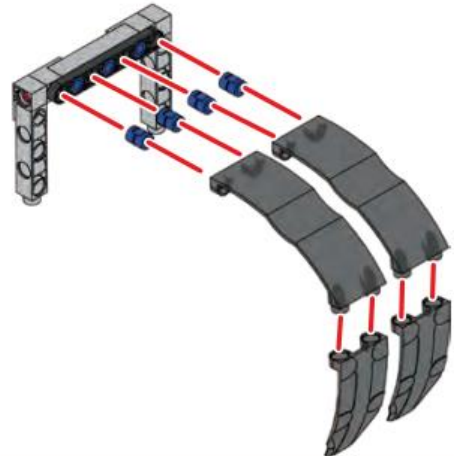

32



33

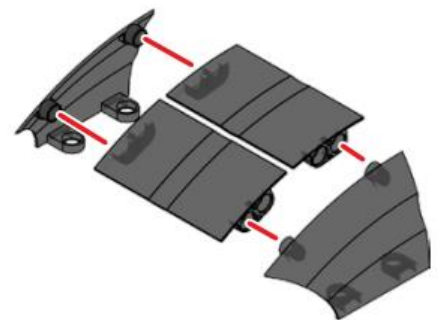



## Electric Car Model 10

34

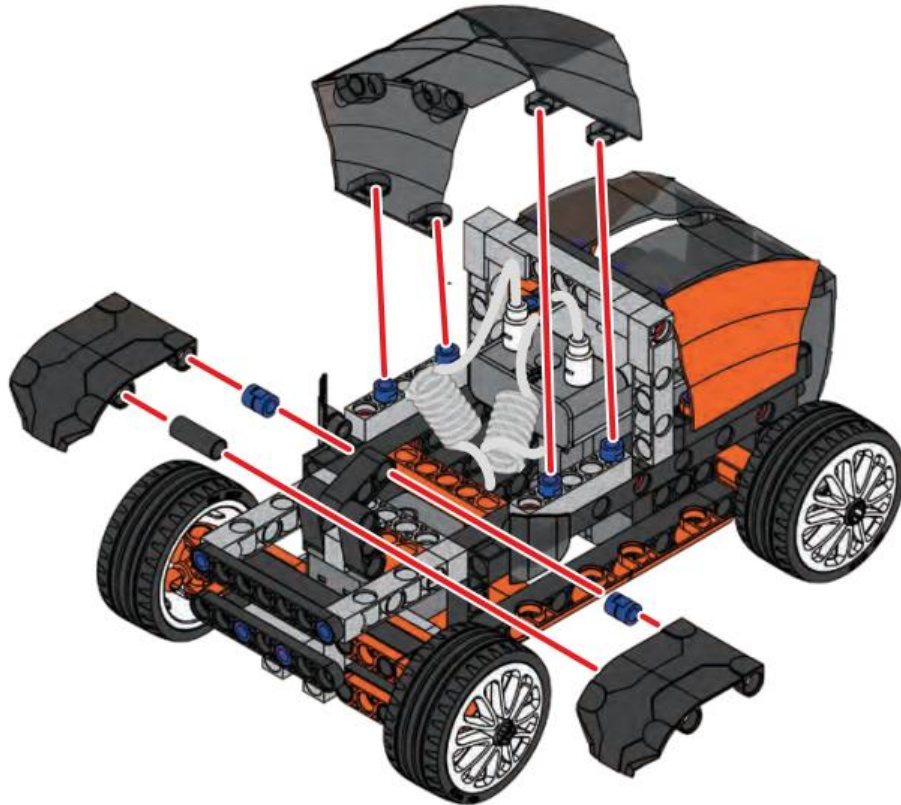

35

Done!

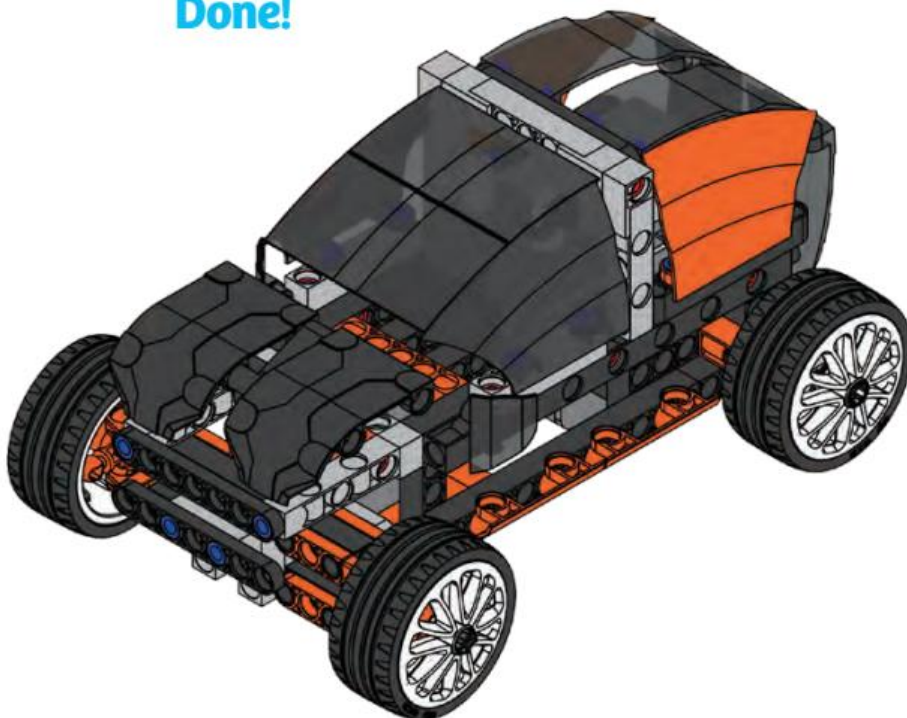





## CHECK IT OUT



## Car of the Future

Here are some key features that the cars of tomorrow might have.

The self-driving car will need a system of **sensors** to detect lanes, other cars, and any other obstacles in its path for that matter.

### SELF-DRIVING CARS

Can you imagine watching a DVD with your parents as your car drives around town? Or all of you playing a board game together while traveling down the highway?

Well, your family's car can't do that yet. But automotive engineers are already working on their own versions of the self-driving car of the future. What do these self-driving cars need?



To make driving decisions, an on-board computer will use the information gathered by the car's many sensors. The computer will decide what to do: brake or accelerate, make a turn, or maybe just park.

A very precise GPS navigation system will be necessary to determine the car's position so that the car can follow the route you have entered into it.





Please browse website



Gigo website



f Gigo FB

Welcome to our newly redesigned Gigo website!

- We now offer four language options (English, Traditional Chinese, Simplified Chinese, Russian).
- Many brilliant videos for product introduction.
- Online product brochures to facilitate timely Browse.

Multi-Language

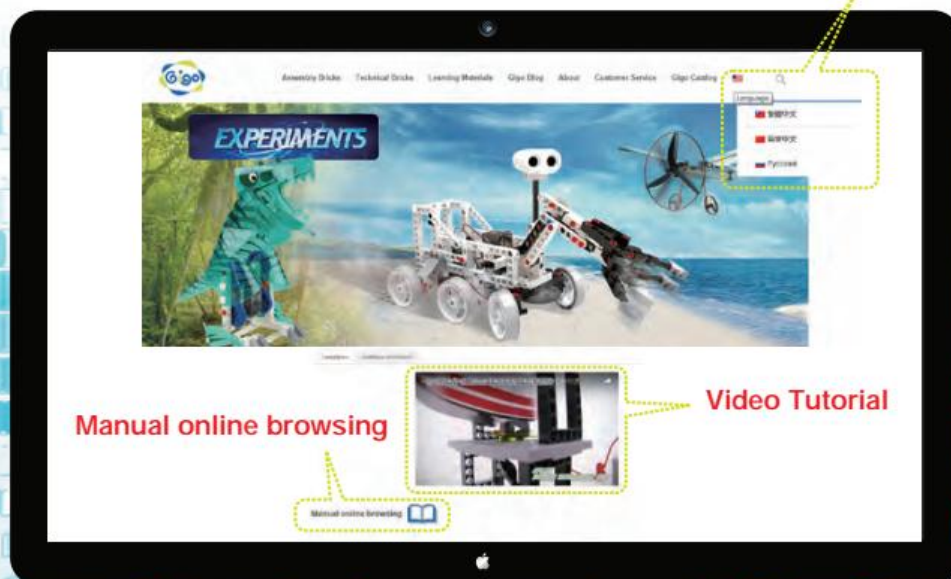

Manual online browsing

Video Tutorial



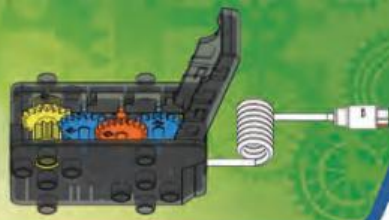

## >>> SAFETY INFORMATION

### Safety Information

**Warning!** Not suitable for children under 3 years. Choking hazard — small parts may be swallowed or inhaled. Store the experiment material and assembled models out of the reach of small children.

**Warning!** Only for use by children aged 8 years and older. Instructions for parents or other supervising adults are included and have to be observed.

Keep packaging and instructions as they contain important information.

### Safety for Experiments with Batteries

>>> The wires are not to be inserted into socket-outlets. Never perform experiments using household current! The high voltage can be extremely dangerous or fatal!

>>> To operate the models, you will need two AAA batteries (1.5-volt, type AAA/LR03) and three AA batteries (1.5-volt, type AA/LR6), which could not be included in the kit due to their limited shelf life.

>>> The supply terminals are not to be short-circuited. A short circuit can cause the wires to overheat and the batteries to explode.

>>> Different types of batteries or new and used batteries are not to be mixed.

>>> Do not mix old and new batteries.

>>> Do not mix alkaline, standard (carbon-zinc), or rechargeable (nickel-cadmium) batteries.

>>> Batteries are to be inserted with the correct polarity. Press them gently into the battery compartment. See page 2.

>>> Always close battery compartments with the lid.

>>> Non-rechargeable batteries are not to be recharged. They could explode!

>>> Rechargeable batteries are only to be charged under adult supervision.

>>> Rechargeable batteries are to be removed from the toy before being charged.

>>> Exhausted batteries are to be removed from the toy.

>>> Dispose of used batteries in accordance with environmental provisions, not in the household trash.

>>> Be sure not to bring batteries into contact with coins, keys, or other metal objects.

>>> Avoid deforming the batteries.

As all of the experiments use batteries, have an adult check the experiments or models before use to make sure they are assembled properly. Always operate the motorized models under adult supervision.

After you are done experimenting, remove the batteries from the battery compartments. Note the safety information accompanying the individual experiments or models!

### Notes on Disposal of Electrical and Electronic Components

The electronic components of this product are recyclable. For the sake of the environment, do not throw them into the household trash at the end of their lifespan. They must be delivered to a collection location for electronic waste, as indicated by the following symbol:



Please contact your local authorities for the appropriate disposal location.

### Dear Parents and Supervising Adults,

Before starting the experiments, read through the instruction manual together with your child and discuss the safety information. Check to make sure the models have been assembled correctly, and assist your child with the experiments.

**We hope you and your child have a lot of fun with the experiments!**

### FCC Part 15 Statement

This device complies with Part 15 of the FCC Rules. Operation is subject to the following two conditions: (1) this device may not cause harmful interference, and (2) this device must accept any interference received, including interference that may cause undesired operation.

Changes or modifications not expressly approved by the party responsible for compliance could void the user's authority to operate the equipment.

NOTE: This equipment has been tested and found to comply with the limits for a Class B digital device, pursuant to Part 15 of the FCC Rules. These limits are designed to provide reasonable protection against harmful interference in a residential installation. This equipment generates, uses and can radiate radio frequency energy and, if not installed and used in accordance with the instructions, may cause harmful interference to radio communications. However, there is no guarantee that interference will not occur in a particular installation. If this equipment does cause harmful interference to radio or television reception, which can be determined by turning the equipment off and on, the user is encouraged to try to correct the interference by one or more of the following measures:

- Reorient or relocate the receiving antenna.
- Increase the separation between the equipment and receiver.
- Connect the equipment into an outlet on a circuit different from that to which the receiver is connected.
- Consult the dealer or an experienced radio/TV technician for help.



# EXPERIMENTS



RUBBER BAND RACERS  
#7403  
5 Models to build  
71 PCS



SPACE MACHINES  
#7337  
10 Models to build  
255 PCS



WATER POWER MINI  
#7389  
6 Models to build  
60 PCS



CROSSBOWS AND CATAPULTS  
#7406  
10 Models to build  
110 PCS



MINI GYRO  
#7395  
20 Models to build  
88 PCS



SMART MACHINES  
#7416  
8 Models to build  
230 PCS



ORNITHOPTER  
#7405  
4 Models to build  
49 PCS



ELECTRICITY & MAGNETISM  
#7065  
10 Models to build  
137 PCS



GECKOBOT  
#7409  
7 Models to build  
176 PCS



MADE IN TAIWAN

**GENIUS TOY TAIWAN CO., LTD.**  
[www.gigotoys.com](http://www.gigotoys.com)

©2016 Genius Toy Taiwan Co., Ltd. All right reserved 201608 V01-01