



# 智能程式補充包

## BASIC PROGRAMMABLE KIT

FUN LAB



# 1268

12 PCS

7+

知識來自於經驗

KNOWLEDGE COMES FROM EXPERIENCE ALONE



20 MODELS TO BUILD

前言 / Introduction	P2
零件表 / Parts List	P3~4
課前準備 / Class Preparations	P5~8
汽車 / Automobile	P9
推土機 / Excavator	P10~11
火星探險號 / Mars Exploration Rover	P12~13
輸送帶 / Conveyor Belt	P14~15
打標機 / Marking Machine	P16~17
機械吊臂 / Mechanical Crane	P18~19
直升機 / Helicopter	P20~21
電風扇 / Electric Fan	P22~23
攪拌機 / Mixer	P24~25
電動床 / Electric Bed	P26~27
電鑽機 / Drill Machine	P28~29
自動餵食器 / Automatic Feeder	P30~31
自動洗車機 / Auto-washing Machine of Automobile	P32~34
塔型吊車 / Tower Crane	P35~37
電子垃圾桶 / Automatic Trash Can	P38~39
自動門 / Automatic Doors	P40~42
避障機械人 / Obstacle Avoiding Robot	P43
追光怪手 / Light – sensitive Excavator	P44~45
避光毛毛蟲 / Light – sensitive Caterpillars	P46~47
建築工程車 / Construction Vehicles	P48~50

各位小朋友，歡迎您加入 Gigo 智高的 FUN LAB 積木實驗室。  
 在 FUN LAB – #1268 智能程式補充包當中，我們添加了更多的趣味零件，  
 透過與 #1261 科學探索組的相互結合，就能延伸出更多的創意。  
 在我們動手組裝的過程當中，不僅能體驗創作的樂趣，更能學習到各種有趣的知識！讓我們將這些知識活用於日常生活吧！  
 那麼，就讓我們一起探索、學習 FUN LAB 趣味實驗室吧！

Hello, everyone! Welcome to join Gigo's Fun Lab.

In the package of #1268 Basic Programmable Kit, a Fun Lab accessories and add-ons, some extra fun parts are included. Working together with Kit #1261 Scientific Tour more creative ideas can be inspired.

During the process of assembly, we will experience the fun of creation and learn various interesting knowledge, which can hopefully be utilized in our everyday life.

Let's work together to explore Gigo's Fun Lab.

## #1268 智能程式補充包 零件表

## #1268 Parts List



1  
B- 扳手  
B-PEG REMOVER  
x 1

2  
C- 智高智能主控盒  
C-Gigo SMART CONTROL BOX  
x1

3  
C-40 倍馬達盒 (DDM)  
C-40X MOTOR WITH WIRE  
CONNECTOR (DDM)  
X4

4  
C- 超音波感測器  
C-ULTRASONIC SENSOR  
X1

5  
C- 光度感應器  
C-ILLUMINANCE SENSOR  
X1

6  
C- 按壓感應器  
C-FORCE SENSOR  
X2

7  
C-MicroUSB 2.0 傳輸線  
C-MicroUSB 2.0 CABLE  
x 1

8  
P- 標示貼紙  
P-LABEL  
x 1

## #1261 科學探索組 需用零件表

Parts Needed from Kit #1261  
Scientific Tour



1

C-8 x 12 底盤  
C-BASE GRID  
x2



2

C-底盤結合器  
C-BASE GRID  
CONNECTOR  
x2



3

C-長結合鍵  
C-LONG PEG  
x15



4

B-短結合鍵  
B-SHORT PEG  
x15



5

C-3 孔長條  
C-3 HOLE ROD  
x4



6

C-3 孔長條側有孔  
C-3 HOLE ROD  
FRONT CLOSED  
x4



7

C-3 孔超長條  
C-3 HOLE  
DUAL ROD  
x4



8

C-5 孔長條  
C-5 HOLE ROD  
x4



9

C-5 孔長條側有孔  
C-5 HOLE ROD  
FRONT CLOSED  
x2

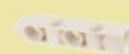

10

C-5 孔超長條  
C-5 HOLE  
DUAL ROD  
x4



11

C-11 孔長條  
C-11 HOLE ROD  
x6



12

C-15 孔超長條  
C-15 HOLE DUAL ROD  
x6



13

C-3 孔 1/4 弧長條  
C-BENDED ROD  
x5



14

C-5 x 5 孔正方形  
C-5X5 FRAME  
x4

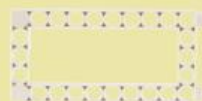

15

C-5 x 10 孔長方框  
C-5X10 FRAME  
x4

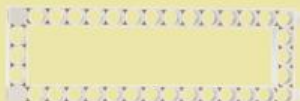

16

C-5 x 15 孔長方框  
C-5X15 FRAME  
x4



17

C-5 x 13 孔超長方框  
C-5X13 DUAL FRAME  
x1



18

C-關節鍵  
C-HINGE  
x2



19

C-單向轉接鍵  
C-FRONT  
CONVERTER  
x2



20

C-雙向轉接鍵  
C-LATERAL  
CONVERTER  
x2



21

C-20T 齒輪  
C-20T GEAR  
x4



22

C-40T 齒輪  
C-40T GEAR  
x2



23

C-60T 齒輪  
C-60T GEAR  
x2



24

C-80T 齒輪  
C-80T GEAR  
x1



25

C-15 孔超長齒條  
C-150mm RACK  
x2



26

C-OD23mm 滑輪  
C-OD23 PULLEY  
x2



27

C-OD33mm 滑輪  
C-OD33 PULLEY  
x2



28

C-OD53mm 滑輪  
C-OD53 PULLEY  
x2



29

C- OD36mm 橡膠圈  
C-OD36 O-RING  
x2



30

C- OD56mm 橡膠圈  
C-OD56 O-RING  
x2



31

C- 30mm II軸  
C-30mm AXLE II  
x3



32

C- 70mm II軸  
C-70mm AXLE II  
x4



33

C- 100mm II軸  
C-100mm AXLE II  
x1



34

C-150mm I軸  
C-150mm AXLE I  
x2



35

C-軸轉接器  
C-ROD  
CONNECTOR  
x2



36

C-二合一結合鍵  
C-TWO-IN-ONE  
CONVERTER  
x4



37

C-10T 鍊輪  
C-10T CHAIN GEAR  
x2



38

C-20T 鍊輪  
C-20T CHAIN GEAR  
x2



39

C-30T 鍊輪  
C-30T CHAIN GEAR  
x2



40

C-鍊條  
C-CHAIN  
x50



41

C-蝸形凸輪  
C-SNAIL CAM  
x1



42

C-軸固定鍵  
C-AXLE FIXING  
x2



43

C-軸扣鍵  
C-AXLE  
CONNECTOR  
x8



44

C-墊片  
C-WASHER  
x1



45

C- 2000mm 特多龍線  
C-2000mm STRING  
x1



46

C-自轉軸鍵  
C-AXLE  
x4



47

C-凸輪連結鍵  
C-CAM  
CONNECTOR  
x1



48

C-渦桿  
C-WORM GEAR  
x1



49

C- OD70 x 13mm 橡膠輪  
C-RACING TIRE  
x2

### 小提醒：

課程開始前，請先搭配補充包說明書，將 #1261 科學探索組的材料挑出，會更方便進行模型創作喔！

Reminders: Before the class, please read the instructions of Accessories and Add-Ons to pick out parts for #1261 Scientific Tour to make models assembly easier.

## 課前準備 *Class preparations*

### 關於新零件

About the new parts Included

### 智高智能控制盒

Gigo SMART CONTROL BOX



**超音波感測器：用以測量目標物的距離**  
ULTRASONIC SENSOR

The ultrasonic sensor sends out ultrasound waves and “listens” for them to bounce off of objects. It gives this information to the app, enabling it to estimate the distance to the objects.



**光度感應器：偵測外部環境光強度數值與變化**  
ILLUMINANCE SENSOR

The illuminance sensor is able to detect changes in the amount of light shining on the sensor. It then sends this information to the app.



**按壓感應器：是一種直接接觸物體，並回傳結果的感測器。**  
FORCE SENSOR

The force sensor, like your fingers, is able to sense if it has come into contact with an object. It then sends this information to the app.



**40 倍馬達盒 (DDM)：此款具有耗電小的優點，且能供適宜功率的馬達驅動器。**  
40X MOTOR WITH WIRE CONNECTOR(DDM)

Motor connect to axles and motor shafts to turn gears and wheels, activating your models. They are powered by the Gigo smart control box.

## CB1 GigoBLOCKLY APP 下載

### INSTALLING THE MOBILE APP

- 在 iOS App Store 或 Android 的 play 商店下載免費應用程式。
- 開啟主控盒開關及 APP 後，平板會自動與最接近的藍牙接收器連線。
- You can download the free app for iOS devices from the iOS App Store or for Android devices from Google Play.
- The mobile app will automatically connect to the Gigo Smart Control Box via Bluetooth. Make sure that Bluetooth is enabled on your tablet and the Gigo Smart Control Box is turned on.



▪ iOS <http://appsto.re/tw/68x3fb.i>



CB1 GigoBlockly

▪ Android <https://ez2o.com/8xD6g>



## CB1 Gigo BLOCKLY APP 介紹

### APP OVERVIEW

CB1 GigoBlockly 是基於 Google Blockly 設計出來的視覺編輯工具。它是搭配本套件智高智能主控盒一起使用。

您可以運用該軟體輕鬆將積木程式加入，移動，配置和刪除來進行編輯。我們的目的是讓程式編寫更加容易，您可以搭配本套件讓機器人聽從指令作動，以使命令它們做您想做的事。

CB1 GigoBlockly is a visual programming tool built using the open-source Google Blockly library. It is configured to interact with the Gigo Smart Control Box in this kit.

The app uses visual blocks of code that can be easily inserted, moved around, configured, and deleted. The goal is to make it easy to write programs to command the robots you build with this kit, so that you can get them to do what you want them to do.

The screenshot displays the CB1 GigoBlockly application interface. At the top, there are logos for Gigo and Acer BYOC EMPOWERED. Below the logos are several motor status indicators (Motor1 to Motor6) with numerical values and directional arrows. On the right side, there is a 'Load Demo Code:' dropdown menu set to 'drawing robot', with version information: 'App: 1.1.0-350', 'FW: 0.9.2a6', and 'CB1: 18:7A:93:12:61:D0'. The main workspace is a grid-based area where a program is being built using visual blocks. The program starts with a 'set item to 1' block, followed by a 'repeat 3 times' loop. Inside the loop, there is a 'do' block containing a 'repeat item times' loop. This inner loop contains two 'Gigo' motor blocks: one for motor id 2 with 'direction clockwise' and 'speed 225', and another for motor id 1 with 'direction counter-clockwise' and 'speed 225'. After the inner loop, there is a 'set item to item + 1' block. The workspace also features a left sidebar with a 'CB1 Status' section and a list of categories: Logic, Loops, Math, Text, Lists, Color, Variables, Functions, and CB1. At the bottom, there are buttons for 'Parse', 'Step', 'Run', 'Stop', 'Save', 'Load', 'CB1', and 'Help'.

## 各部分功能介紹：

## FEATURES OVERVIEW

## 面板控制區

## Control Panel Area

## CB1 Status

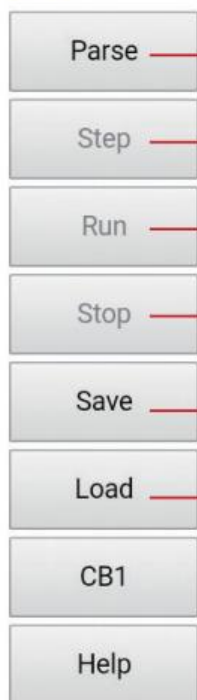

在畫面右手邊有些按鈕是程序操作區，它們是用來指揮與呈現 CB1 狀態。

- CB1 GigoBlockly 狀態指示區：控制與控制盒的連線與斷線，連線時狀態呈現藍色閃爍狀態，離線為黑色。
- 程序操作區：編譯、步進、執行、停止。當你在積木程式編碼區放置一些程序積木程式後，就可以利用這些按鈕將積木程式轉成程序代碼並執行他們。編譯按鈕會把積木程式上傳到智高智能主控盒；步進按鈕可以一步步執行程序並讓你觀察每一步的結果；執行則是讓你從頭到尾不間斷執行，而停止可以把在從程序循環中停止。
- 儲存與載入程序按鈕可以幫你存下已撰寫好的程序，下面的檔案選單可以讓你選擇不同的區域加以存取。
- CB1 GigoBlockly status indicator: This changes color when the Gigo Smart Control Box is connected to the app, and it blinks is blue light when there is activity between the Gigo Smart Control Box and the app.
- Program operation buttons:
  - Parse:** This button checks the code and uploads it to the Gigo Smart Control Box.
  - Step:** This button allows you to run through the code blocks one by one, to see the effects of each one. This is useful when debugging new programs.
  - Run:** This button runs, or executes, the program on the Gigo Smart Control Box.
  - Stop:** This button stops the entire program from running.
- **Save and load programs:** To save a program, choose one of the programs listed in the menu and then press the save button. To load a previously saved program, choose one of the programs listed in the menu and press the load program. The program will load in the block coding area.

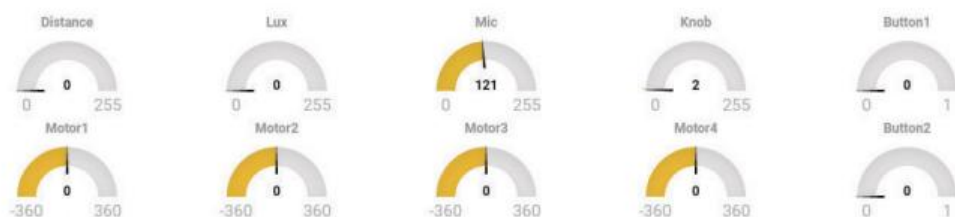

- 感測器狀態顯示區：這些儀表用來顯示各感測器與馬達的狀態。
- Sensor status display: These gauges show the real-time readings from the sensors plugged into the Gigo Smart Control Box.



## 積木程式編碼區

## WRITING A PROGRAM

您可以修改現有的範例程式或重新編寫您自己的積木程式。

方法如下：

點選積木程式工具箱 (圖示 A) 任一類別選項會顯示該選單中的所有功能，選擇其中一個積木程式塊拖曳到中間程式編輯區 (如圖示 B)；積木程式塊之間可以互相連接和組合以形成新的積木程式塊。積木程式塊也可以堆疊在彼此之上。

**重要提醒：**當運行程式時，編輯軟體將從上到下執行你的積木程式。

您可以 (如圖示 C) 點擊積木程式塊的選單或欄位來更改程式參數或數值。

You can modify the existing demo programs or write your own program. Here's how:

Tap one of the sections in the block toolbox (A). This will open a bar which shows all the functions within that menu (B). Then drag and drop one of the blocks into the center coding area of the app.

Blocks can be connected and placed within one another to form new blocks of code. Code blocks can also be stacked on top of each other.

**Important:** When you run the program, the app will carry out your code from top to bottom, starting at the top.

You can change the variable parameters or values in code blocks by tapping on the menus or fields (C).

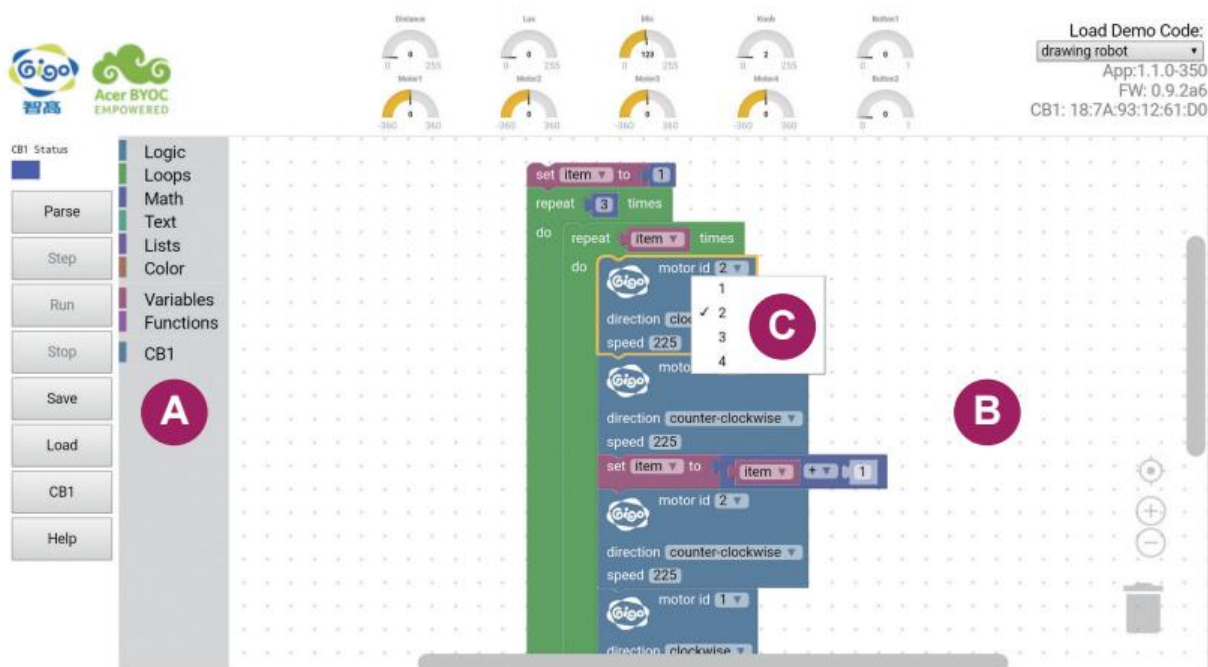

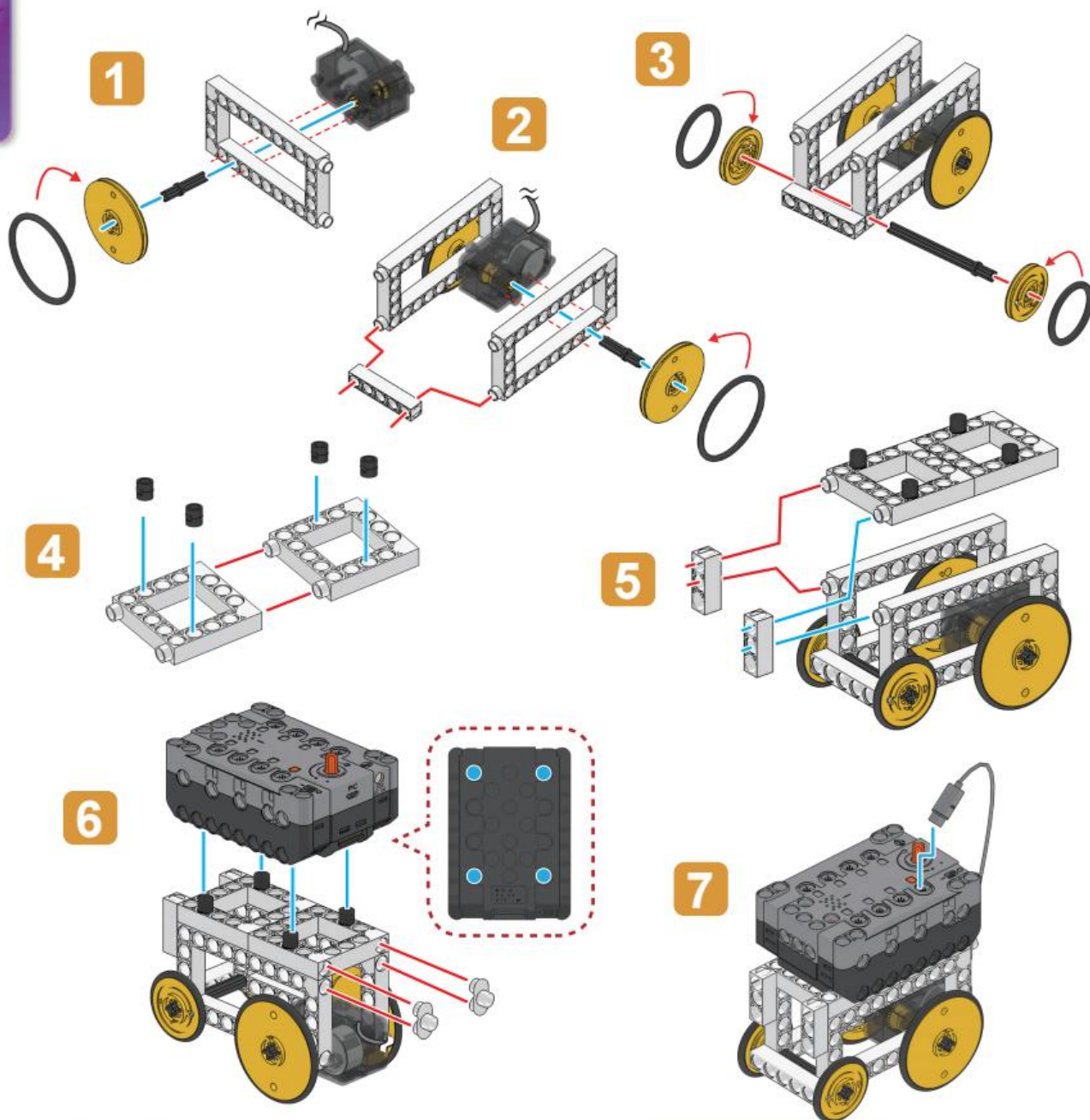

完成  
Done

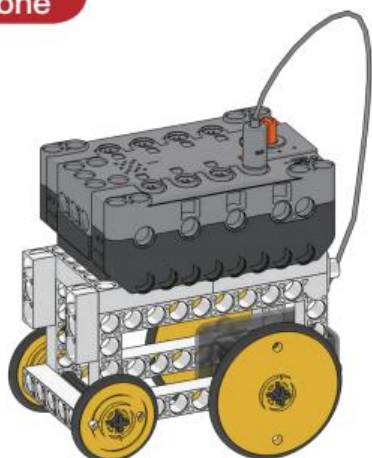

程式示例  
Program Example

```

repeat 10 times
do
  motor id 1
  direction counter-clockwise
  speed 270
  motor id 1
  direction clockwise
  speed 0
  
```

3	4	7	11	13	14	15	20	21	27	28	29	30	31	32	
x3	x2	x3	x3	x4	x2	x3	x2	x1	x2	x2	x2	x2	x3	x2	
35	36	48	2	3											
x2	x2	x1	x1	x2											

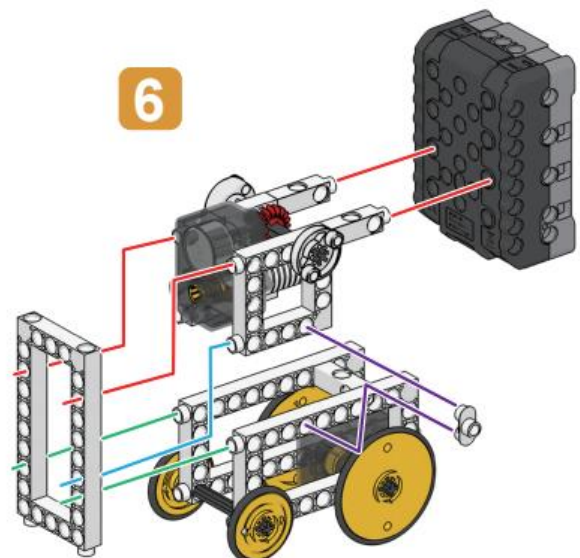
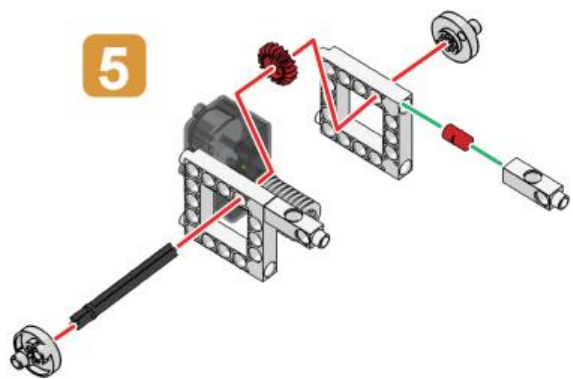
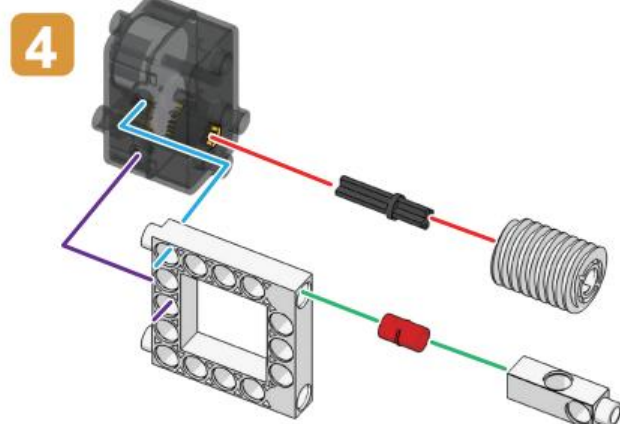
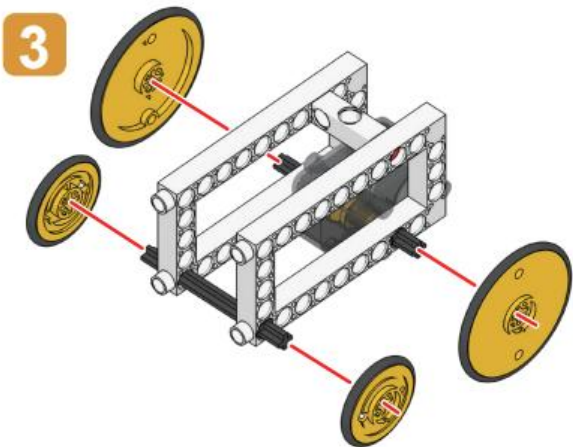
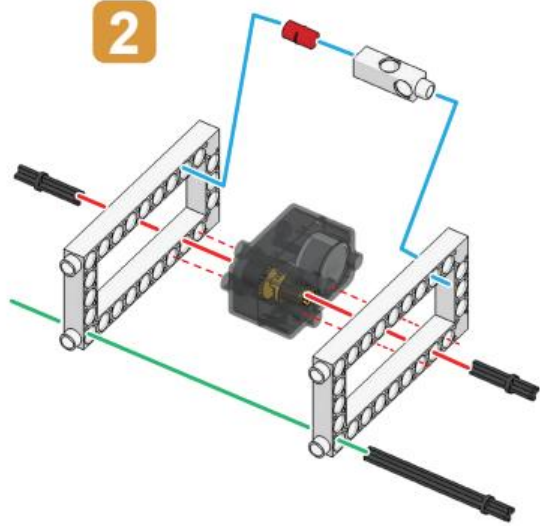
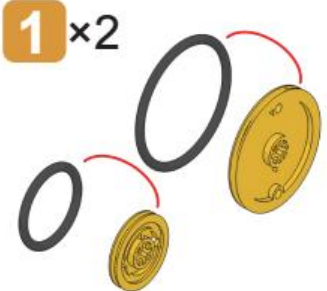

## 推土機

## Excavator

7

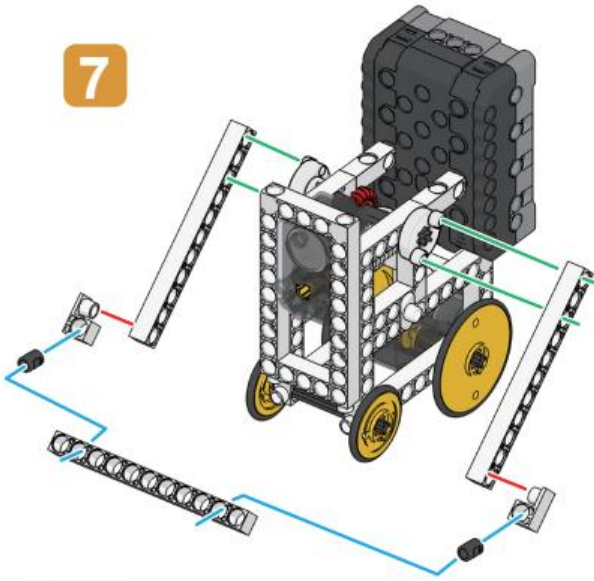

8

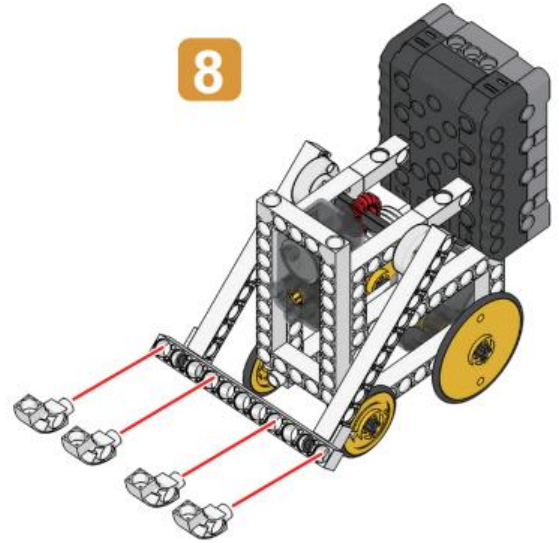

9

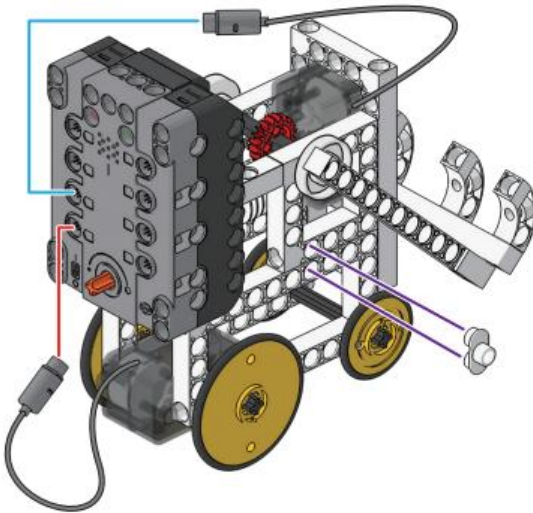

完成  
Done

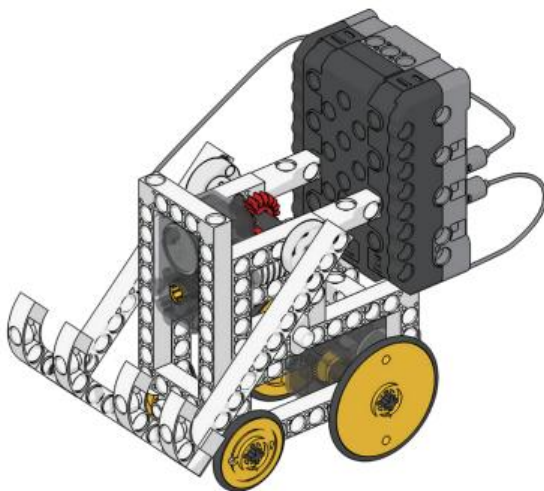

### 程式示例 Program Example

```

repeat 3 times
do
  motor id 1
  direction counter-clockwise
  speed 180
  repeat 3 times
  do
    motor id 2
    direction clockwise
    speed 345
  repeat 3 times
  do
    motor id 2
    direction counter-clockwise
    speed 345
  motor id 1
  direction counter-clockwise
  speed 0
  motor id 2
  direction clockwise
  speed 0
  
```

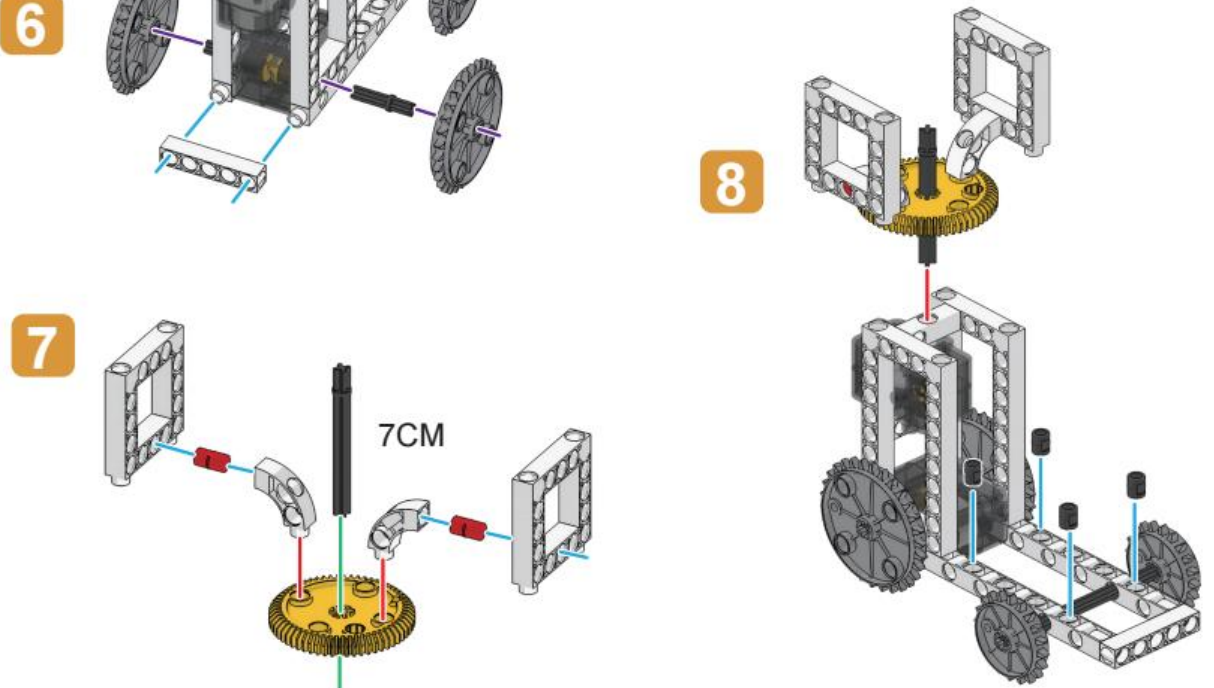
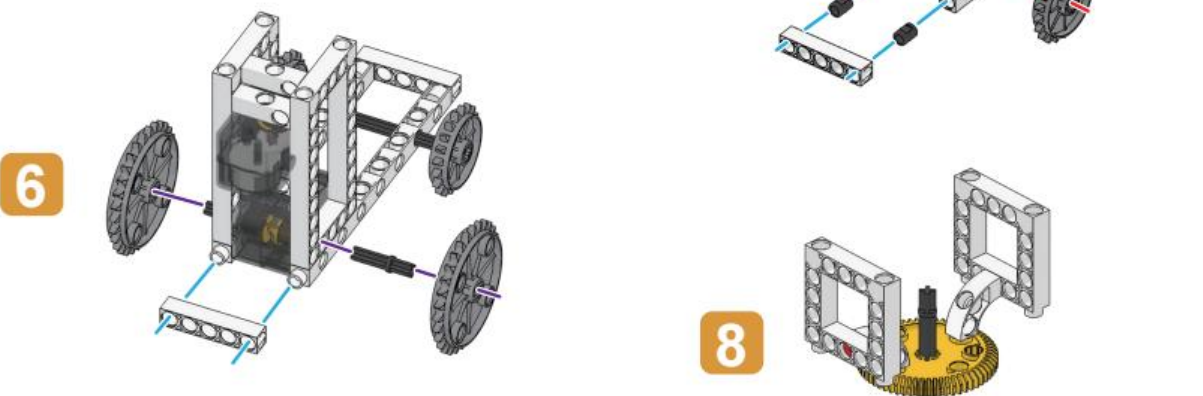
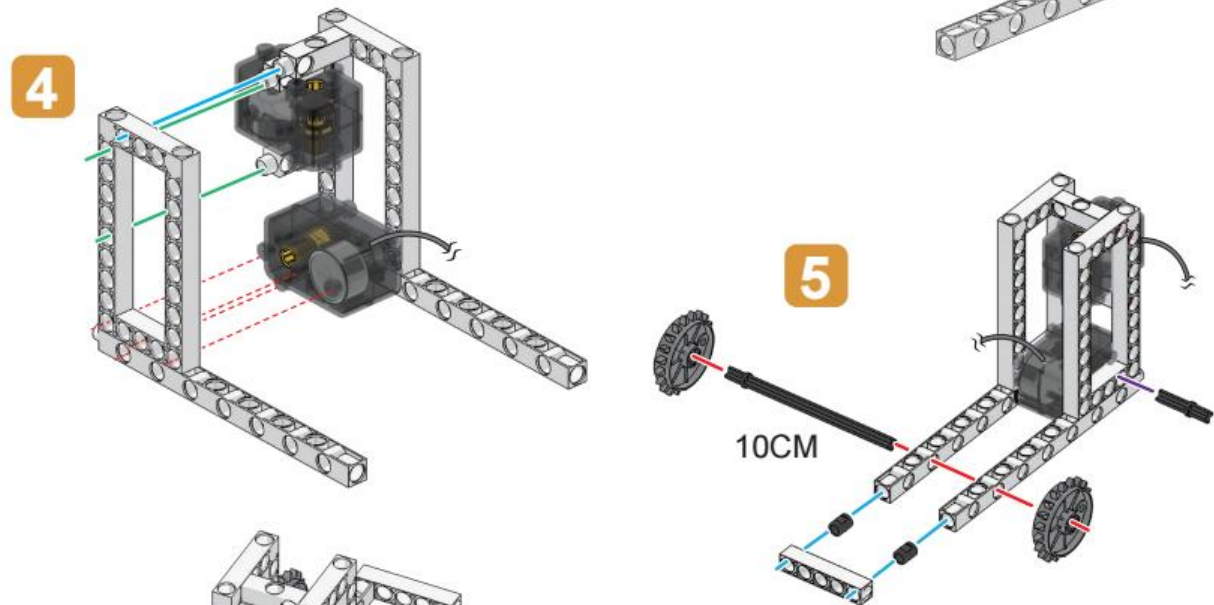
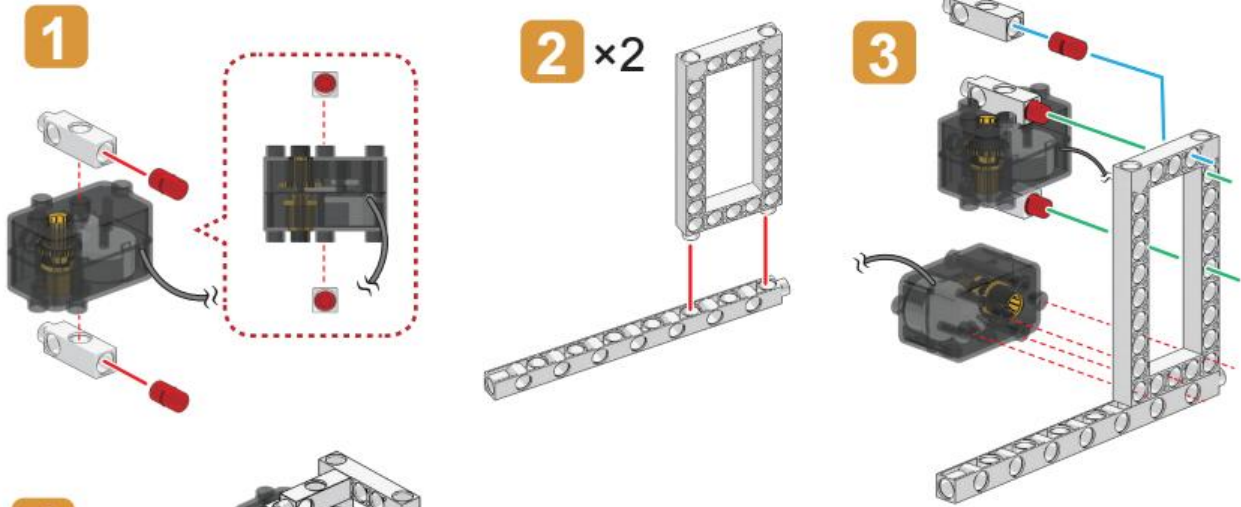
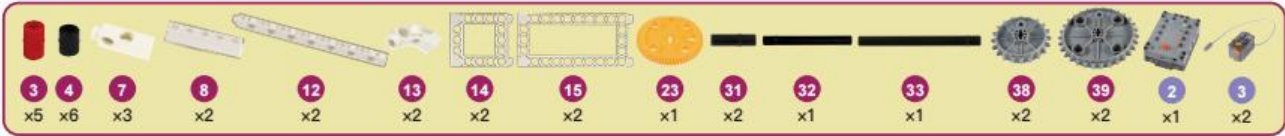

9

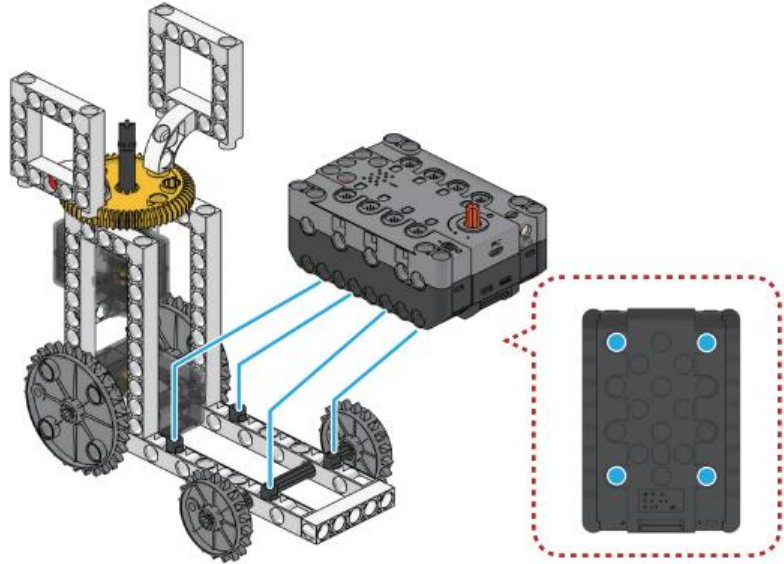

10

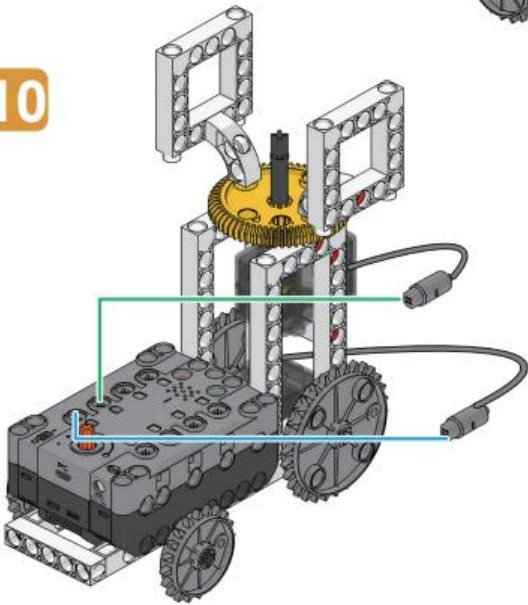

完成  
Done

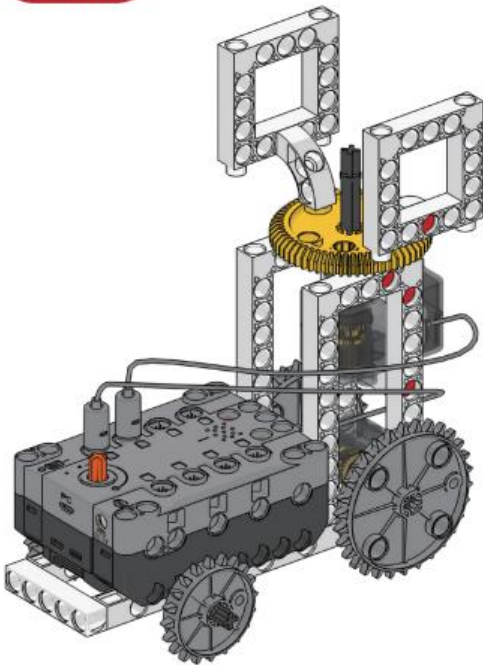

### 程式示例 Program Example

```

repeat 5 times
do
  motor id 1
  direction clockwise
  speed 270
  play buzzer demo
repeat 5 times
do
  motor id 2
  direction clockwise
  speed 300
  motor id 1
  direction clockwise
  speed 0
  motor id 2
  direction clockwise
  speed 0
  
```

														
1	2	4	8	14	15	21	22	23	32	37	40	2	3	
x2	x2	x10	x3	x4	x2	x1	x2	x1	x4	x2	x50	x1	x1	

1

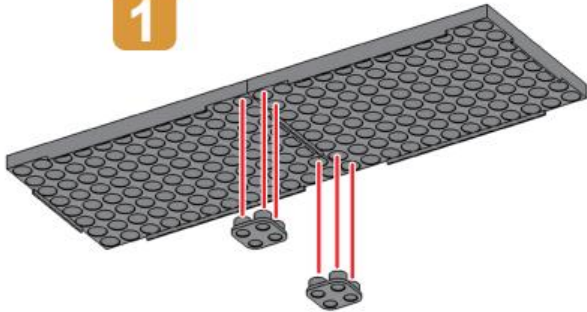

2

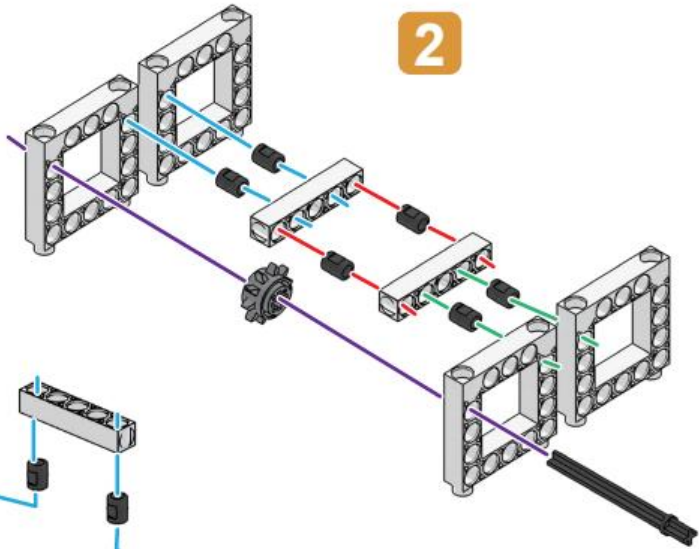

3

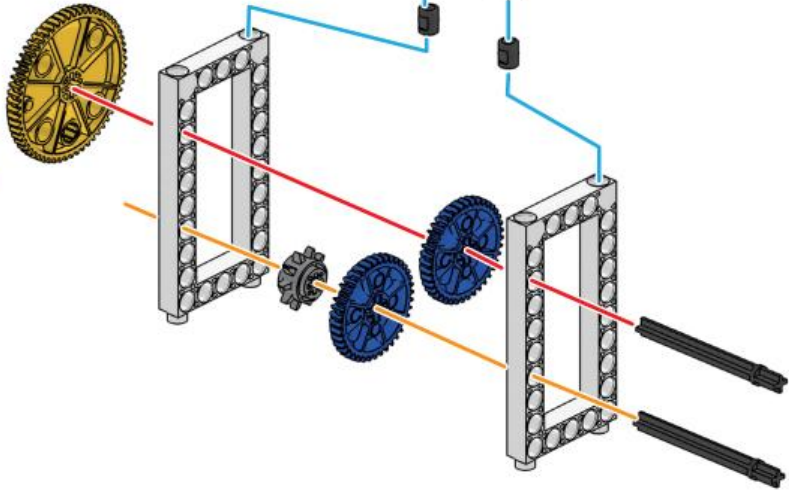

4

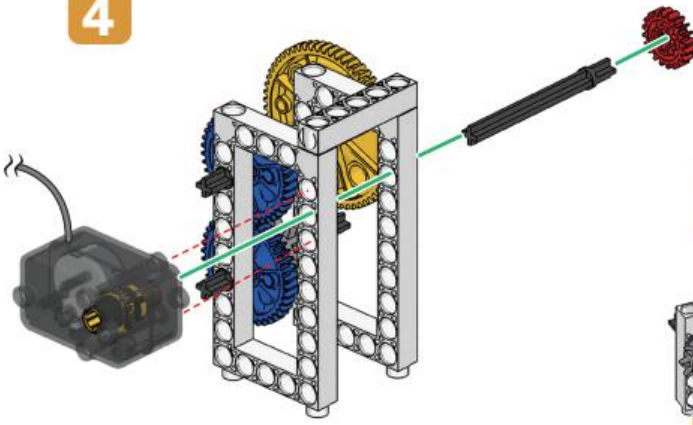

5

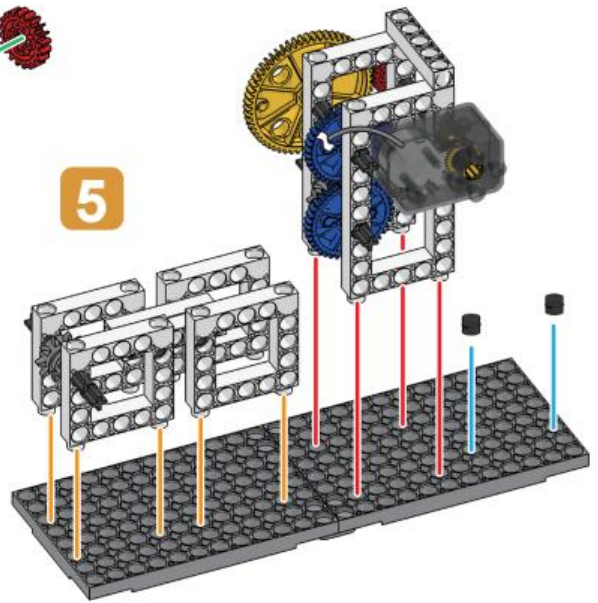

## 输送带

## Conveyor Belt

6

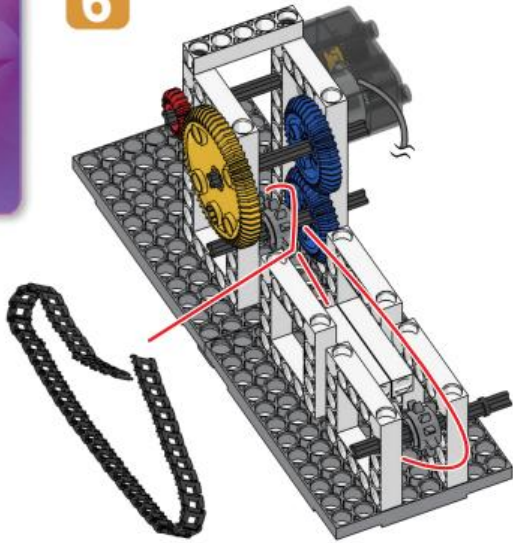

7

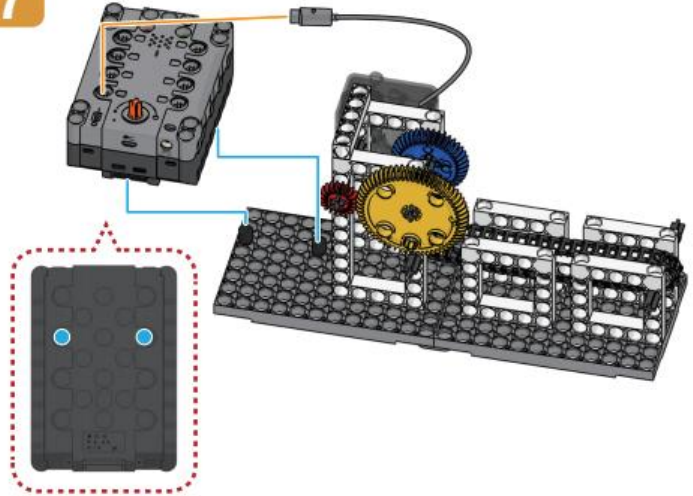

完成  
Done

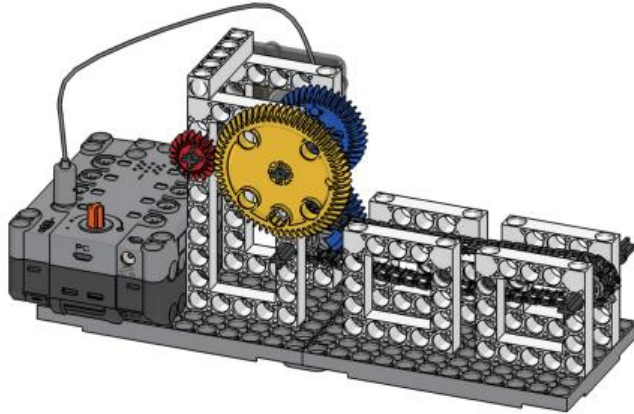

### 程式示例 Program Example

```

Repeat while
  get knob sensor data > 0
do
  if
    get knob sensor data > 10 and get knob sensor data < 30
  do
    motor id 1
    direction clockwise
    speed 90
  else if
    get knob sensor data > 30 and get knob sensor data < 140
  do
    motor id 1
    direction clockwise
    speed 150
  else if
    get knob sensor data > 140 and get knob sensor data < 220
  do
    motor id 1
    direction clockwise
    speed 345
  else
    motor id 1
    direction clockwise
    speed 0
  
```



1	2	3	4	6	8	14	15	16	19	21	25
x2	x2	x6	x12	x2	x2	x2	x2	x2	x2	x4	x2
27	28	31	32	46	2	3					
x1	x1	x2	x2	x2	x1	x2					

1

2 x2

3

4

5

6

7

8

## 打標機

## Marking Machine

9

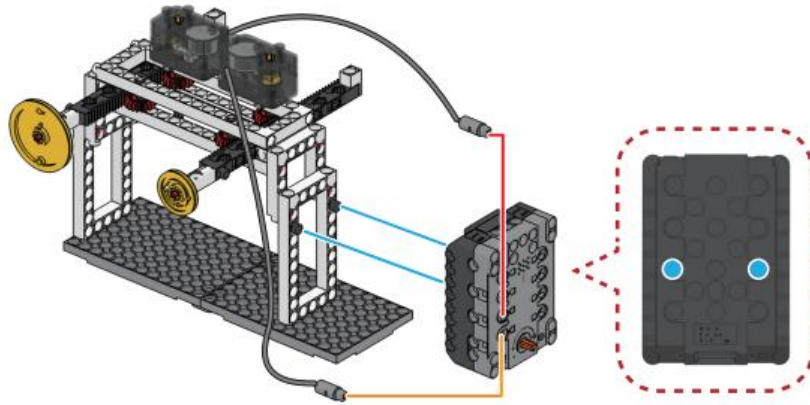

完成  
Done

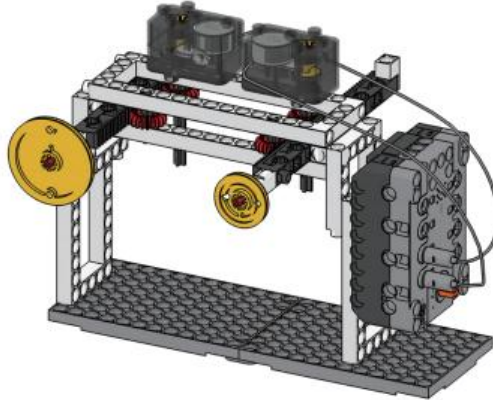















## 程式示例 Program Example









```

repeat while
  get knob sensor data >= 0
do
  if
    get knob sensor data >= 20 and
    get knob sensor data <= 70
  do
    repeat 3 times
      do
        motor id 1
        direction clockwise
        speed 90
        motor id 2
        direction clockwise
        speed 90
      repeat 3 times
        do
          motor id 1
          direction counter-clockwise
          speed 90
          motor id 2
          direction counter-clockwise
          speed 90
        else if
          get knob sensor data >= 70 and
          get knob sensor data <= 220
        do
          repeat 3 times
            do
              motor id 1
              direction clockwise
              speed 180
              motor id 2
              direction clockwise
              speed 180
            repeat 3 times
              do
                motor id 1
                direction counter-clockwise
                speed 180
                motor id 2
                direction counter-clockwise
                speed 180
              else
                motor id 1
                direction clockwise
                speed 0
                motor id 2
                direction clockwise
                speed 0

```

														
1	2	3	4	7	8	10	13	14	15	16	21			
x2	x2	x5	x10	x2	x4	x3	x2	x3	x4	x2	x4			x4

  

							
25	31	32	35	36	2	3	
x1	x3	x2	x2	x1	x1	x2	

1



2

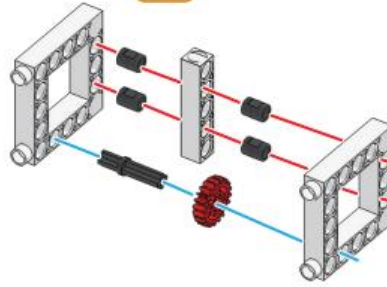

3

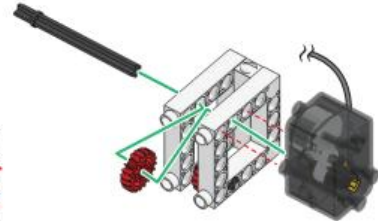

4

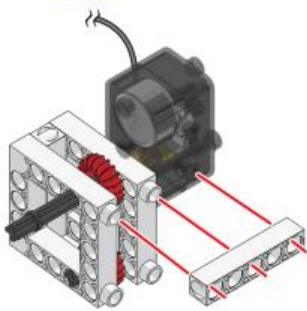

5

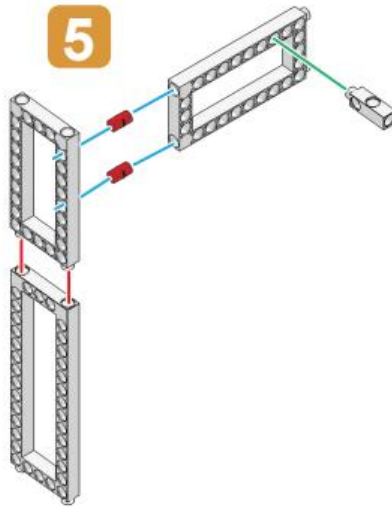

6

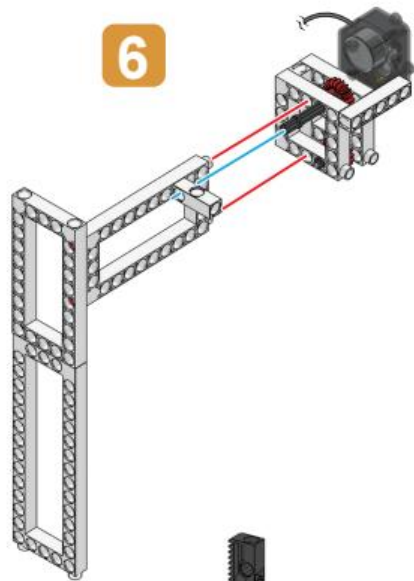

7

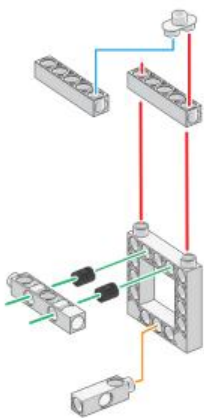

8

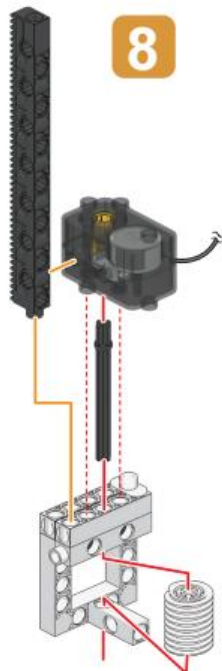

9

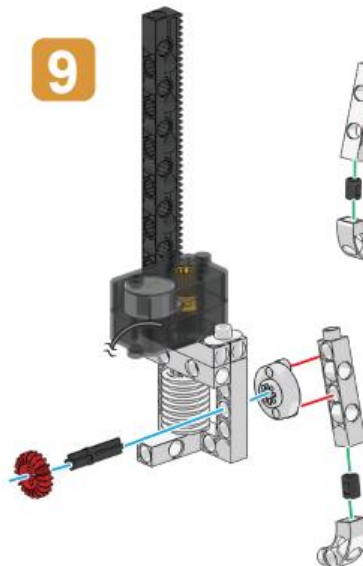

10

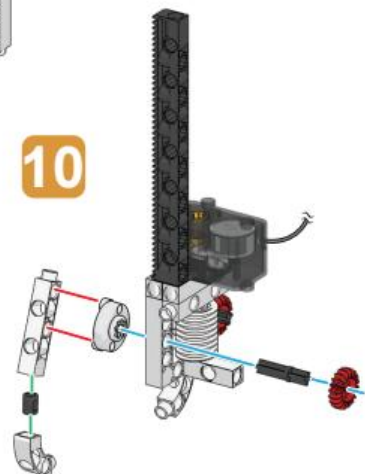

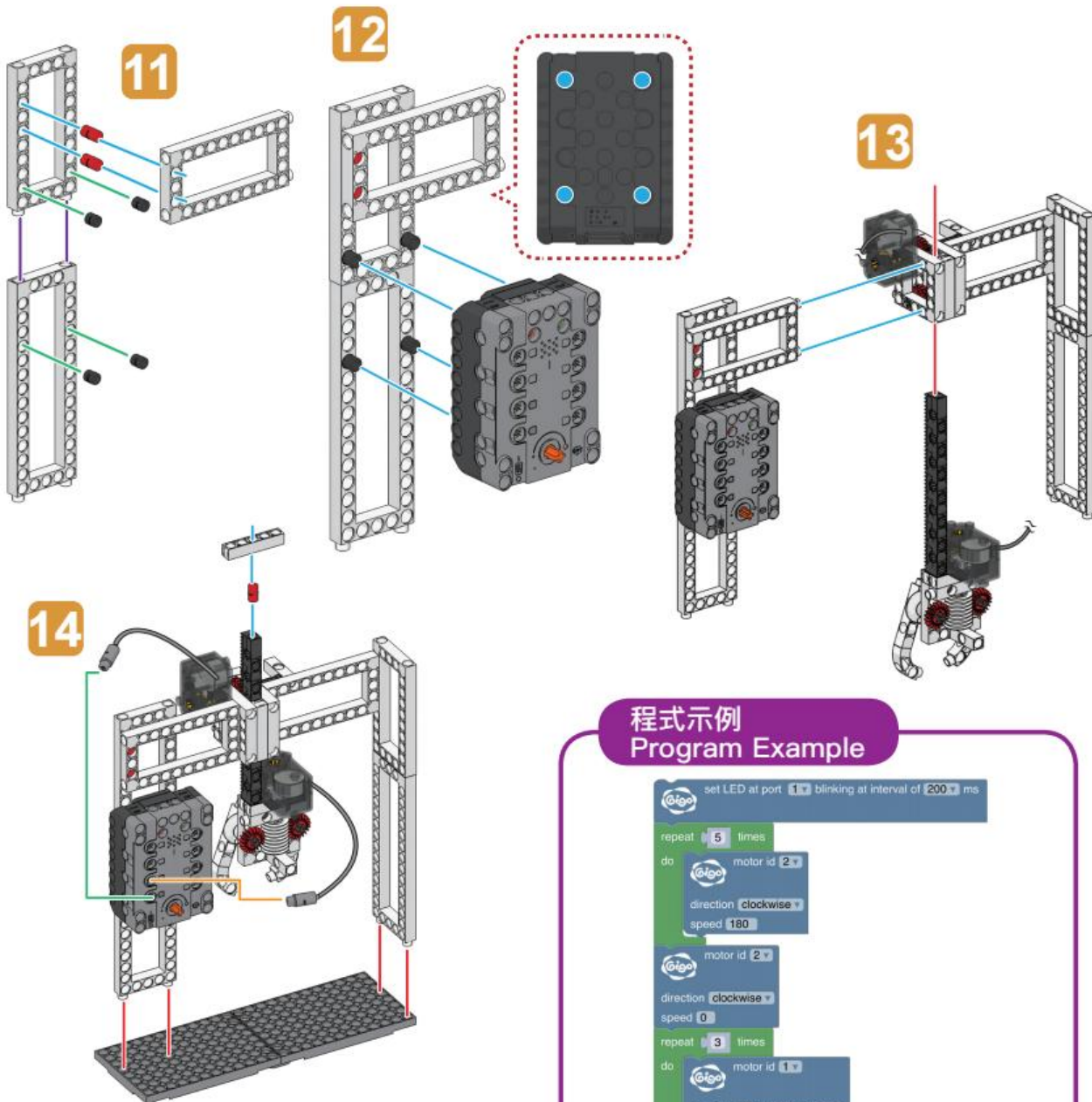

完成  
Done

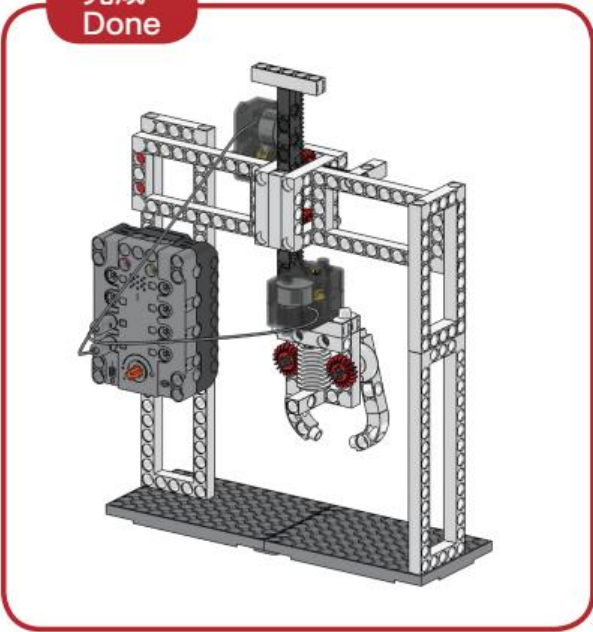

### 程式示例 Program Example

```

set LED at port 1 blinking at interval of 200 ms
repeat 5 times
do
  motor id 2
  direction clockwise
  speed 180
  motor id 2
  direction clockwise
  speed 0
repeat 3 times
do
  motor id 1
  direction counter-clockwise
  speed 180
  motor id 1
  direction clockwise
  speed 0
repeat 5 times
do
  motor id 2
  direction counter-clockwise
  speed 180
  motor id 2
  direction clockwise
  speed 0
repeat 3 times
do
  motor id 1
  direction clockwise
  speed 180
  motor id 1
  direction clockwise
  speed 0
set LED at port 1 blinking at interval of off ms
  
```

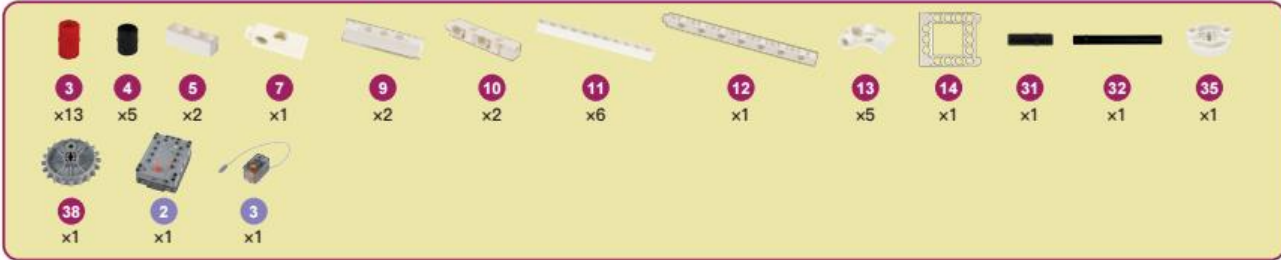

1 x2

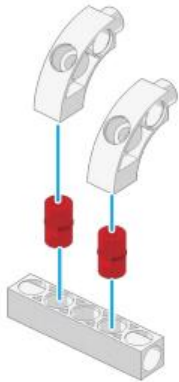

2

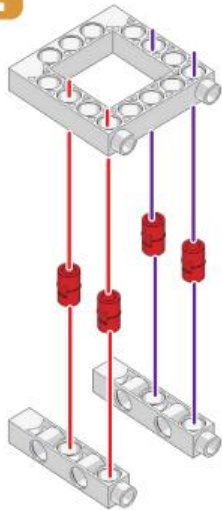

3

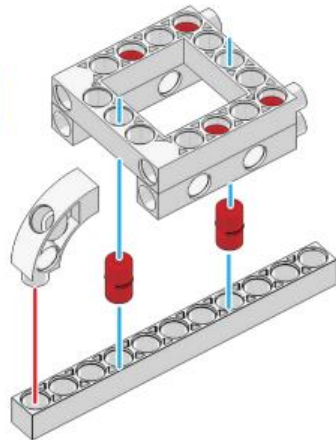

4

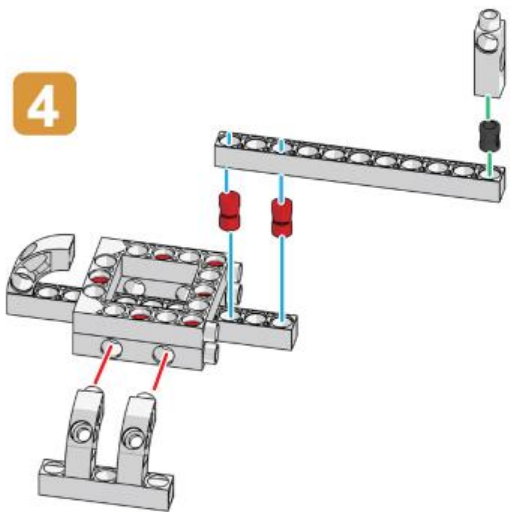

5

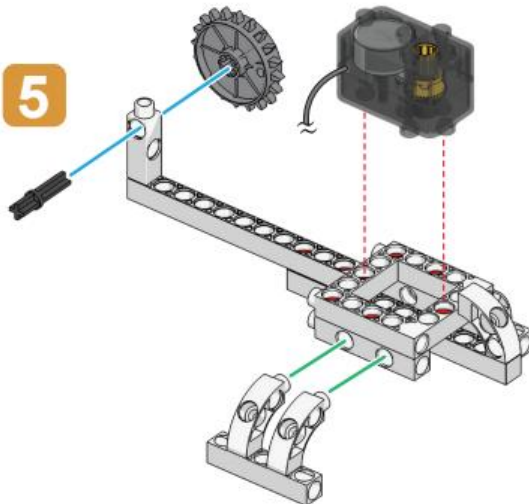

6 x2

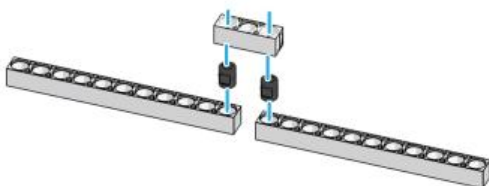

7

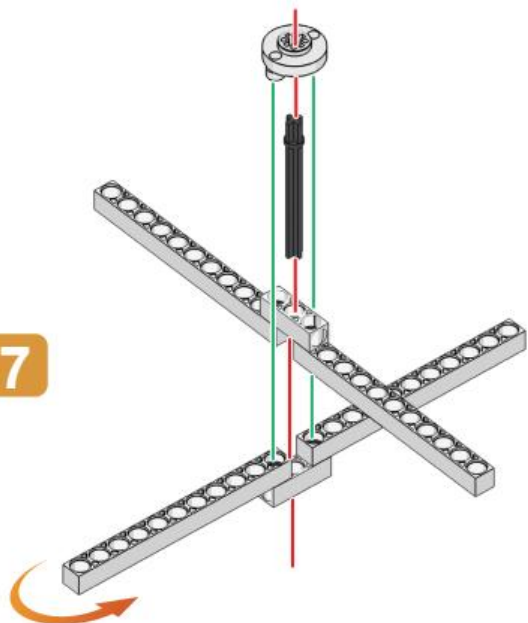

## 直升機

## Helicopter

8

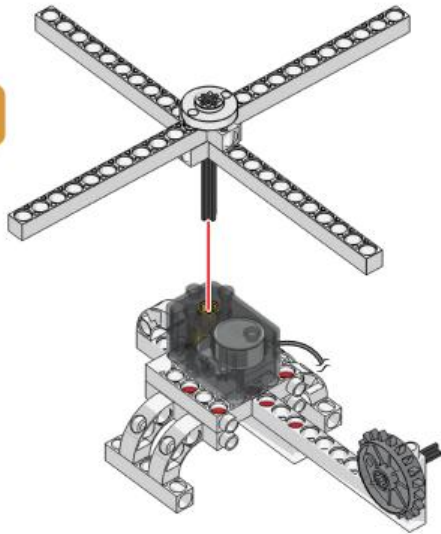

9

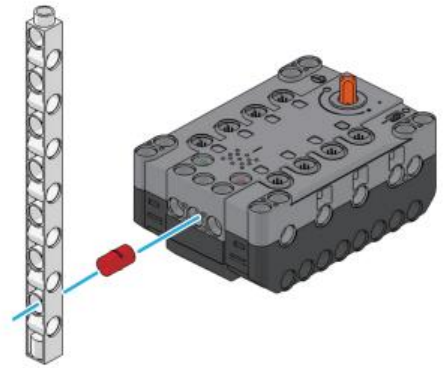

10

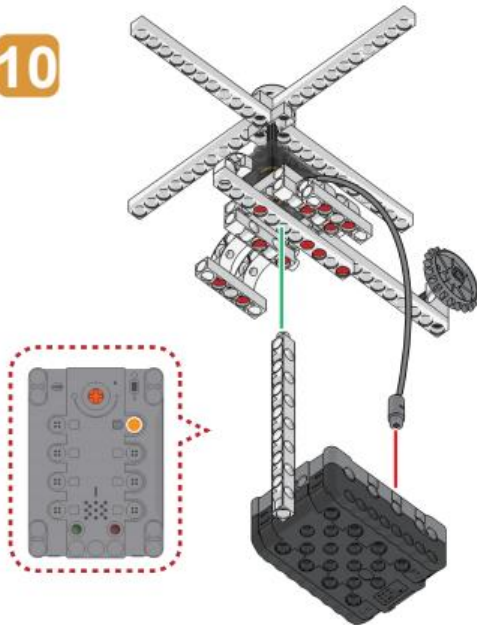

完成  
Done

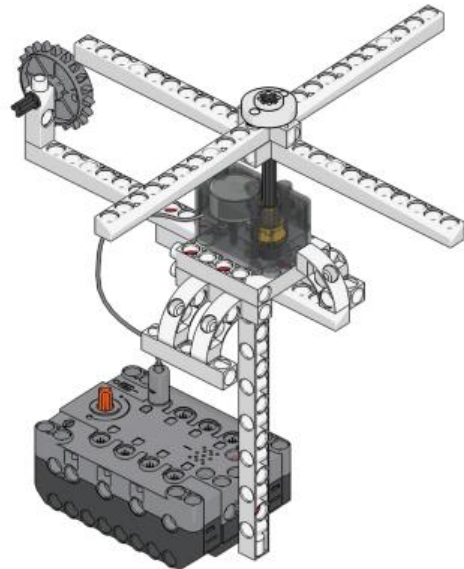

### 程式示例 Program Example

```

repeat while
  get knob sensor data > 10
do
  if
    get microphone sensor data ≥ 220
  do
    motor id 1
    direction clockwise
    speed 345
  else
    motor id 1
    direction clockwise
    speed 0
  motor id 1
  direction clockwise
  speed 0
  
```



1

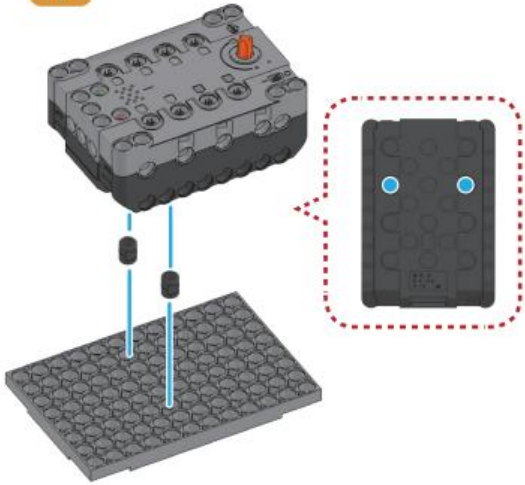

2

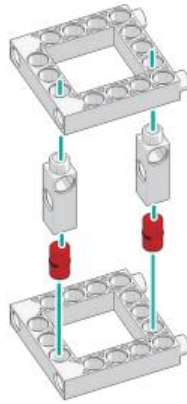

3

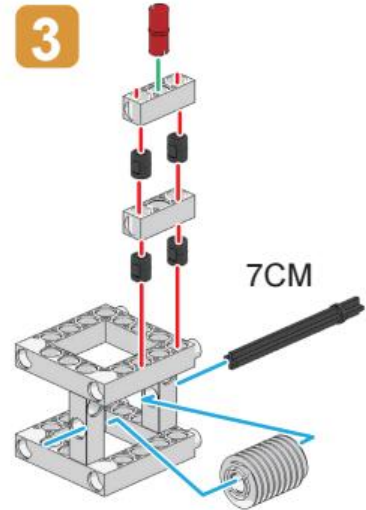

4

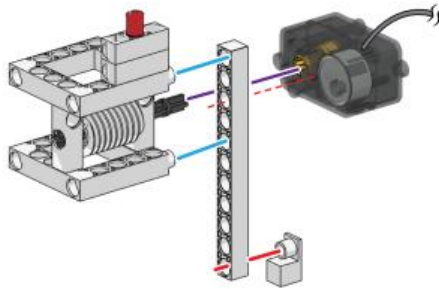

5

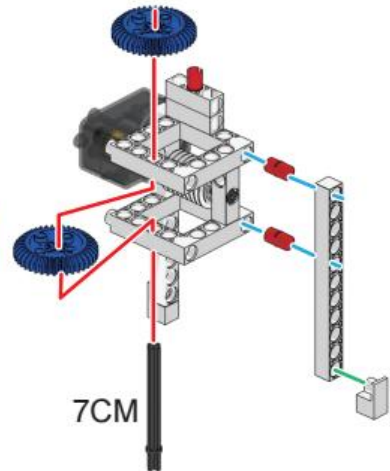

6

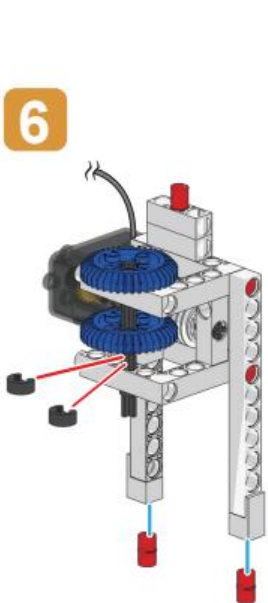

7

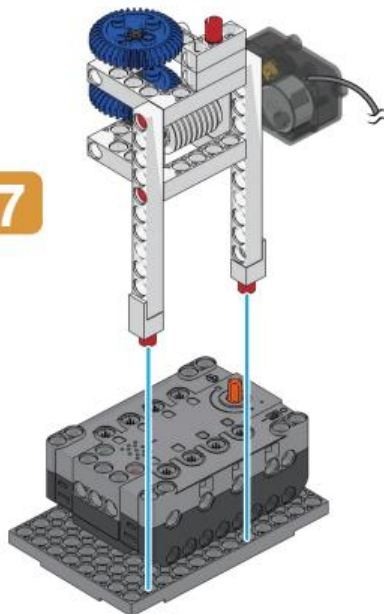

8

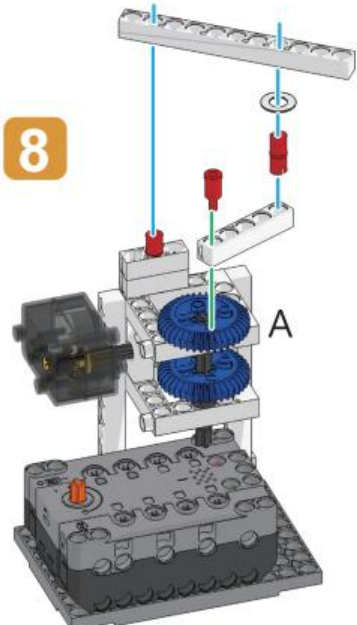

## 電風扇

## Electric Fan

9

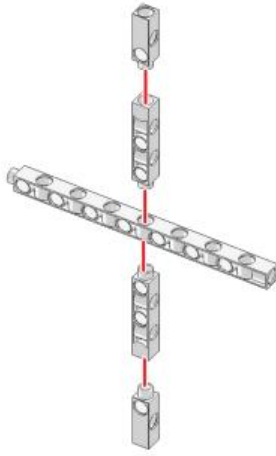

10

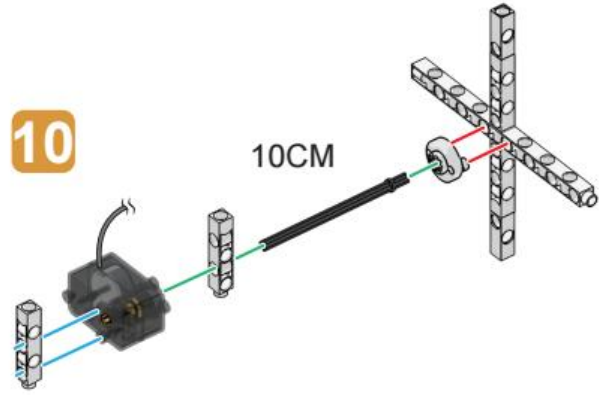

11

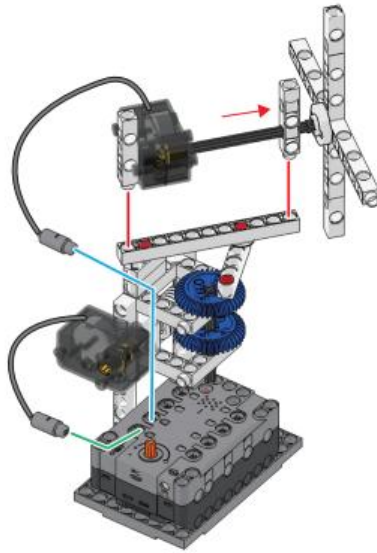

完成  
Done

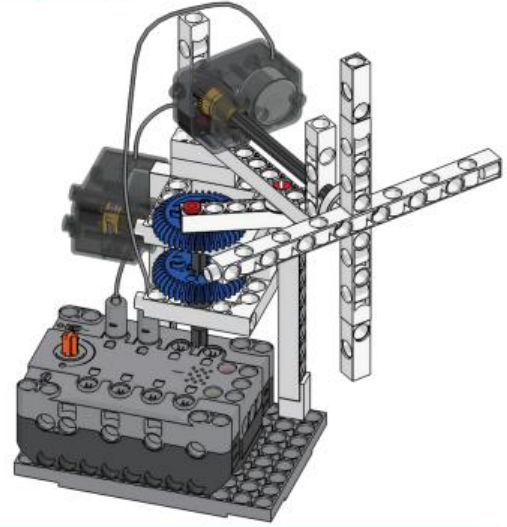

### 程式示例 Program Example

```

repeat while
  get knob sensor data >= 10
do
  if
    get knob sensor data >= 30 and get knob sensor data <= 70
  do
    motor id 1
    direction clockwise
    speed 270
    motor id 2
    direction clockwise
    speed 90
  else if
    get knob sensor data >= 70 and get knob sensor data <= 220
  do
    motor id 1
    direction clockwise
    speed 270
    motor id 2
    direction counter-clockwise
    speed 345
  else
    motor id 1
    direction clockwise
    speed 0
    motor id 2
    direction clockwise
    speed 0
  motor id 1
  direction clockwise
  speed 0
  motor id 2
  direction clockwise
  speed 0
  
```



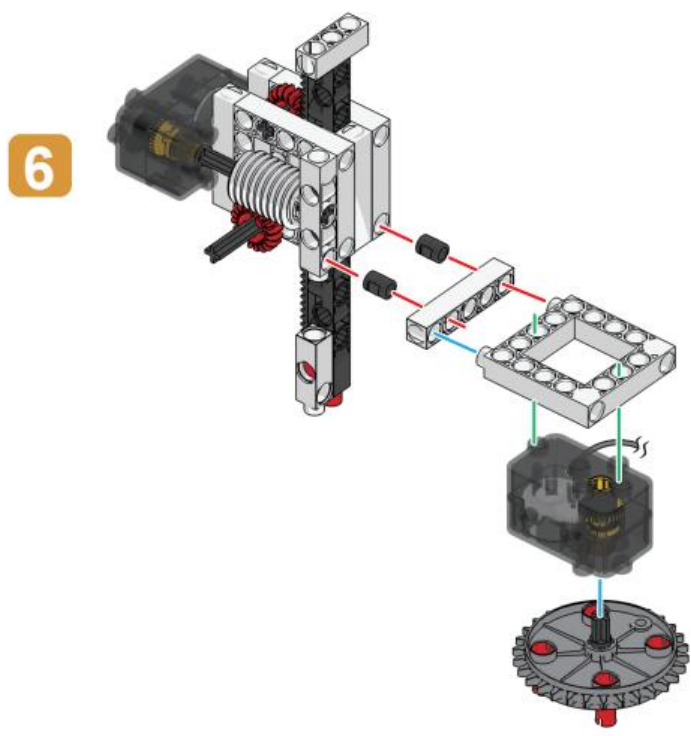
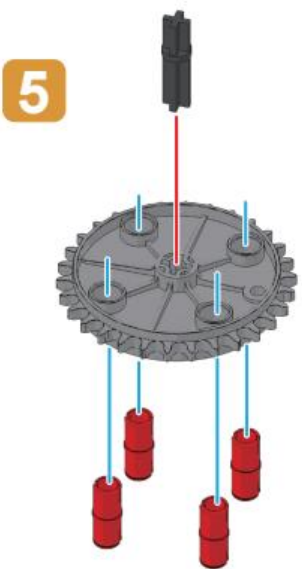
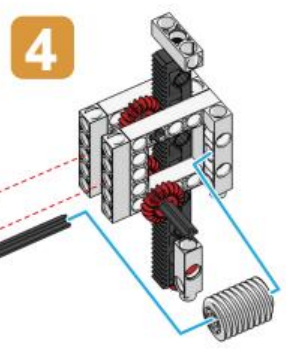
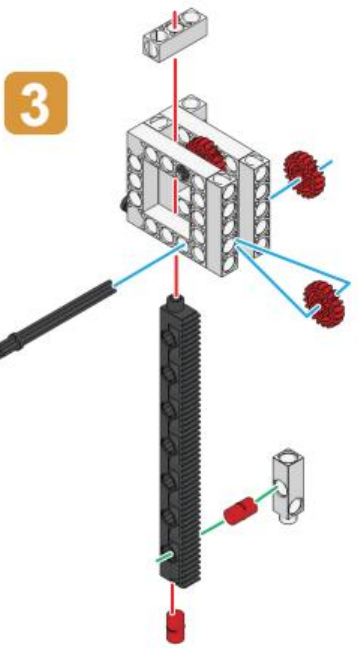
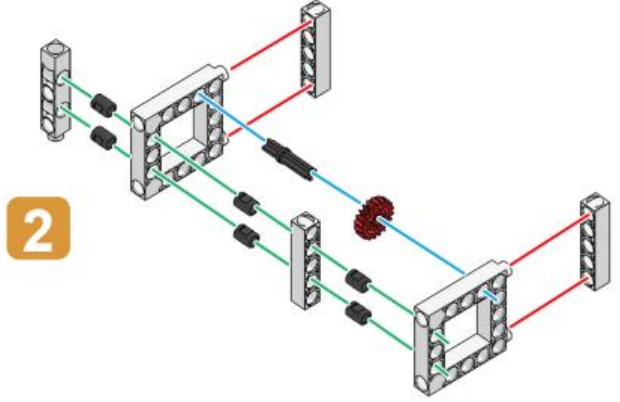
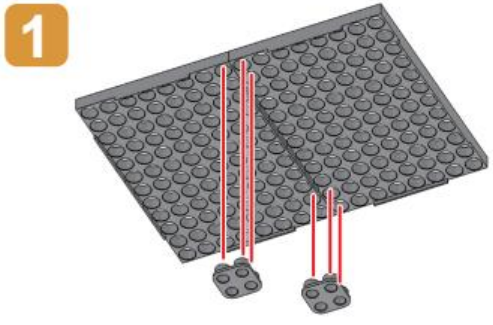
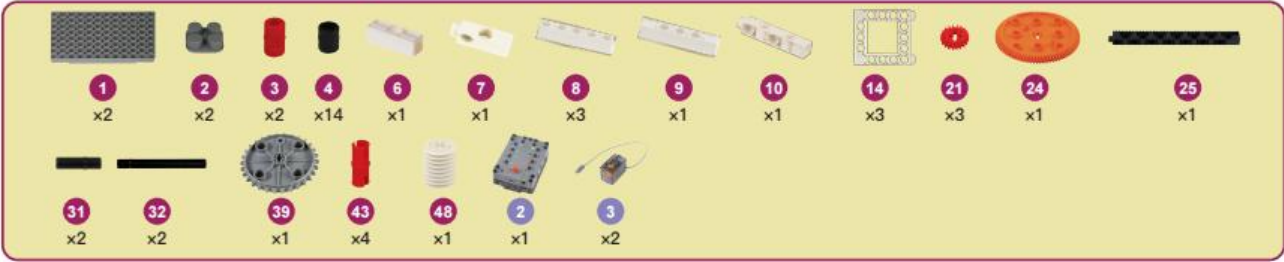

## 攪拌機

Mixer

7



8

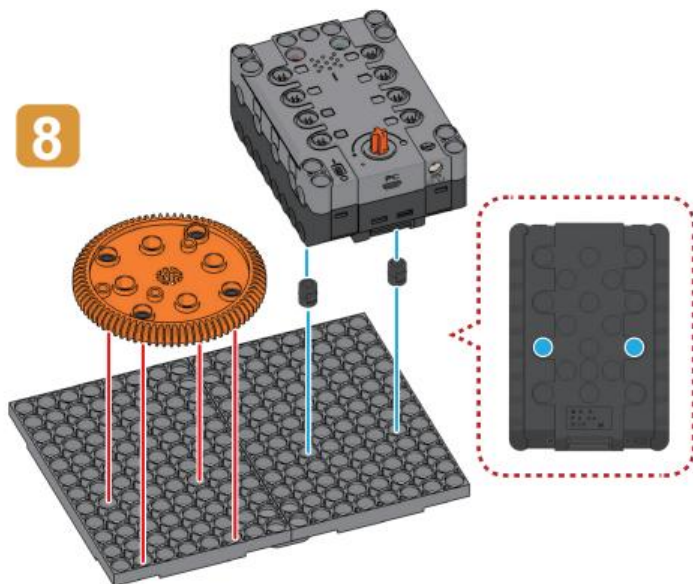

9

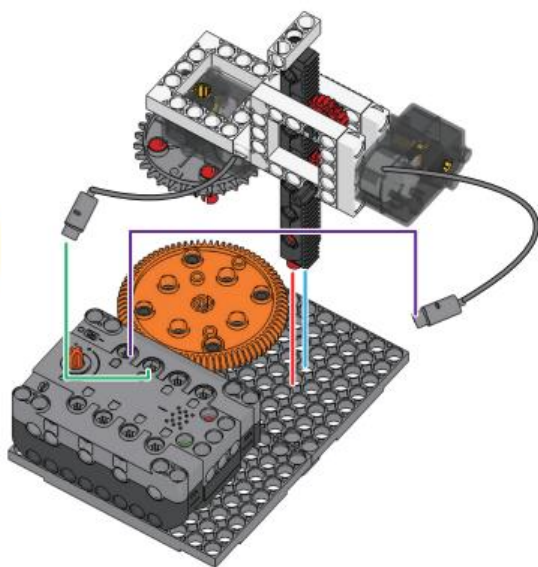

完成  
Done

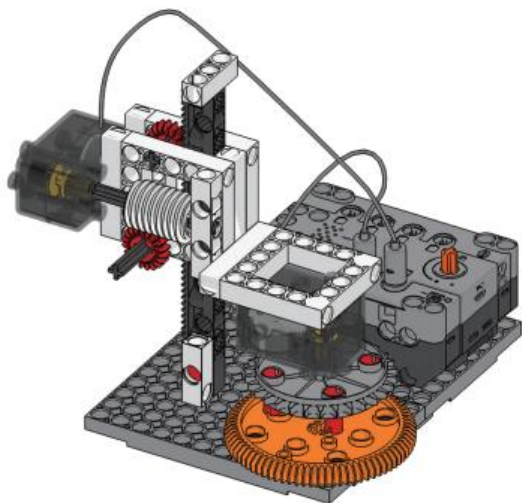

### 程式示例 Program Example

```

play buzzer demo
repeat 5 times
do
  motor id 1
  direction clockwise
  speed 180
  motor id 1
  direction clockwise
  speed 0
  set LED at port 2 blinking at interval of 100 ms
repeat 10 times
do
  motor id 2
  direction clockwise
  speed 345
  motor id 2
  direction clockwise
  speed 0
  set LED at port 2 blinking at interval of off ms
repeat 5 times
do
  motor id 1
  direction counter-clockwise
  speed 180
  motor id 1
  direction counter-clockwise
  speed 0
  
```

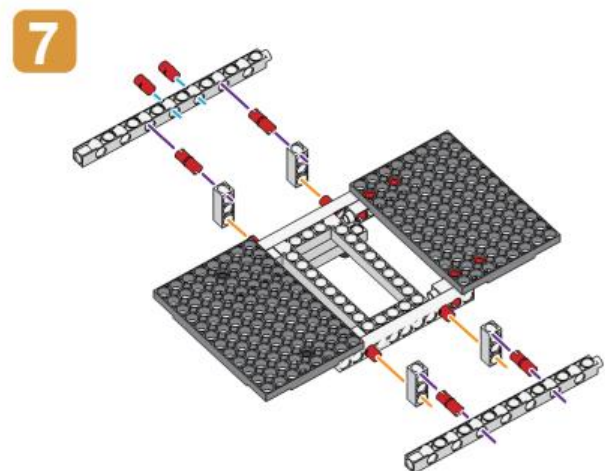
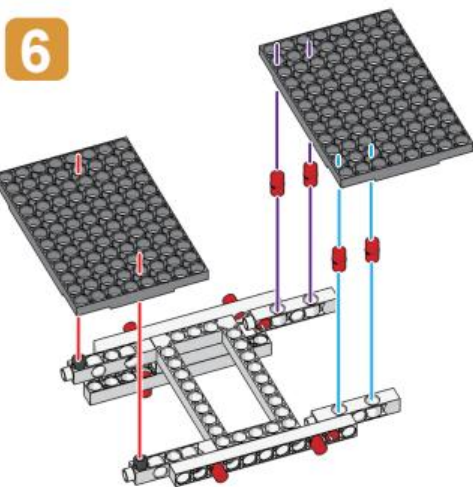
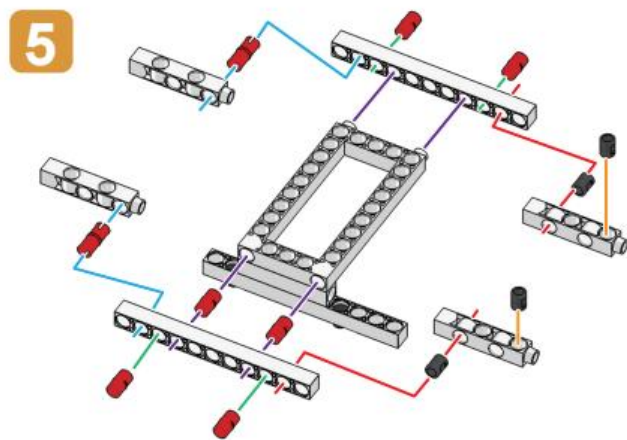
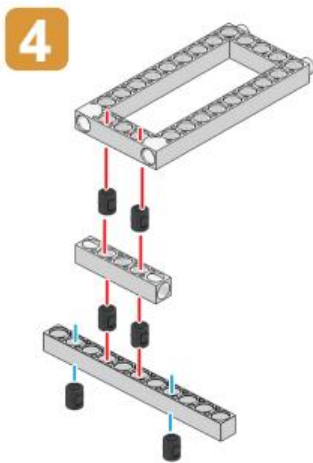
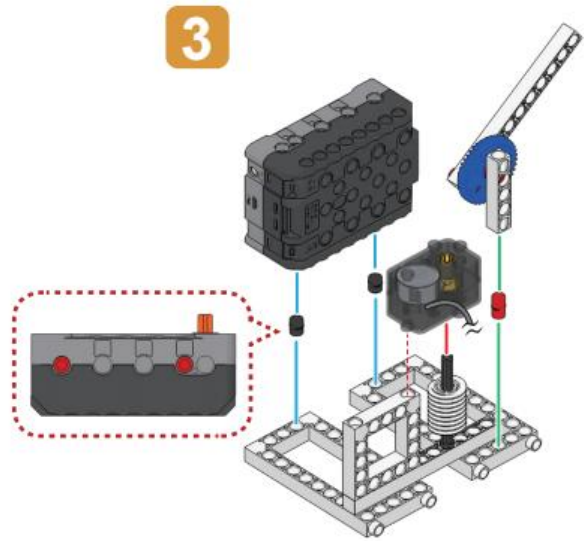
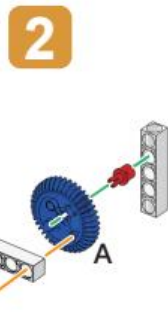
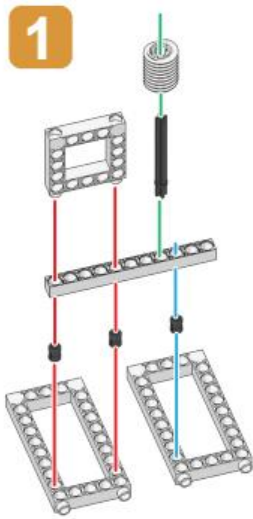
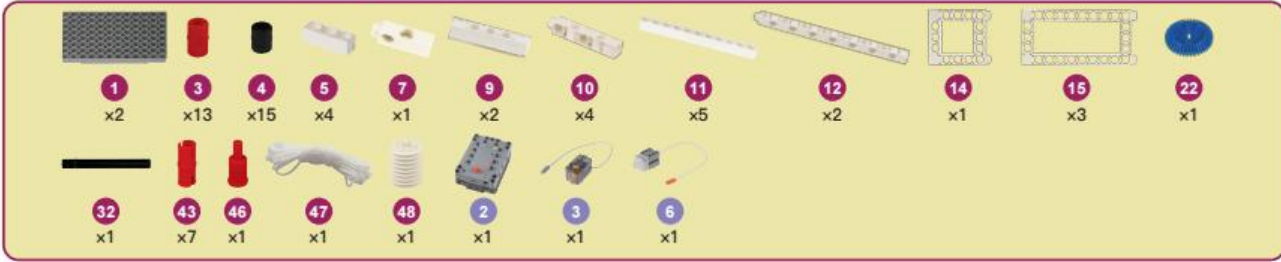

## 電動床

## Electric Bed

8

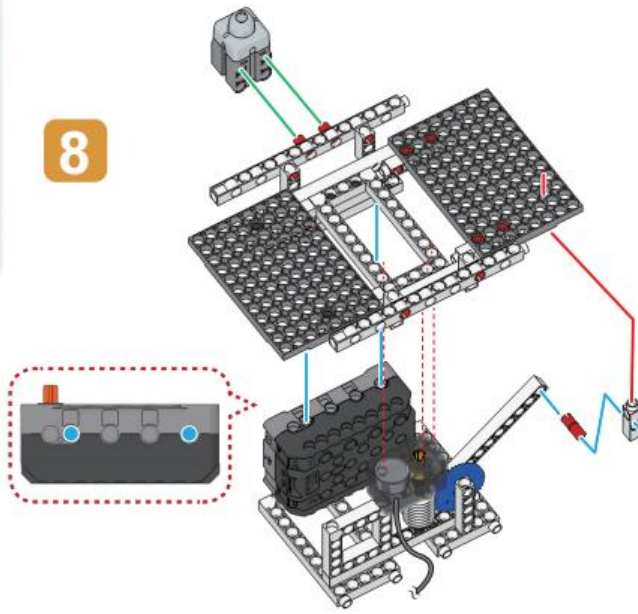

9

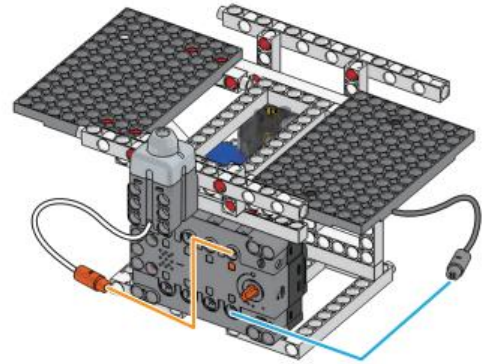

完成  
Done

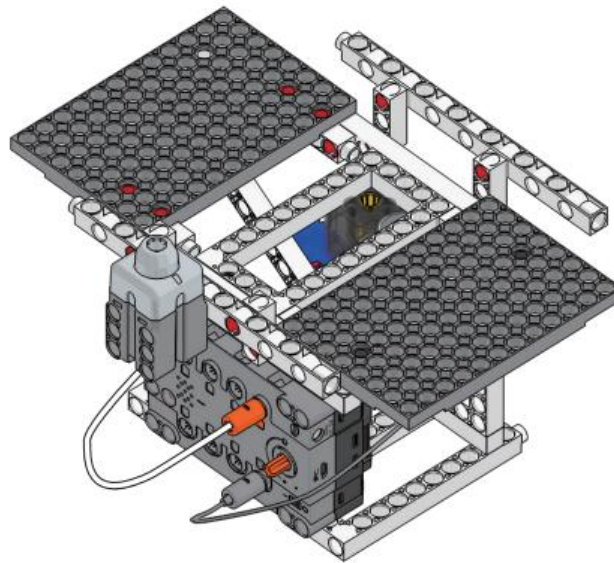

程式示例  
Program Example

```
repeat while true
do
  if get button 1 sensor data = 1
  do
    motor id 1
    direction clockwise
    speed 270
  else
    motor id 1
    direction clockwise
    speed 0
```

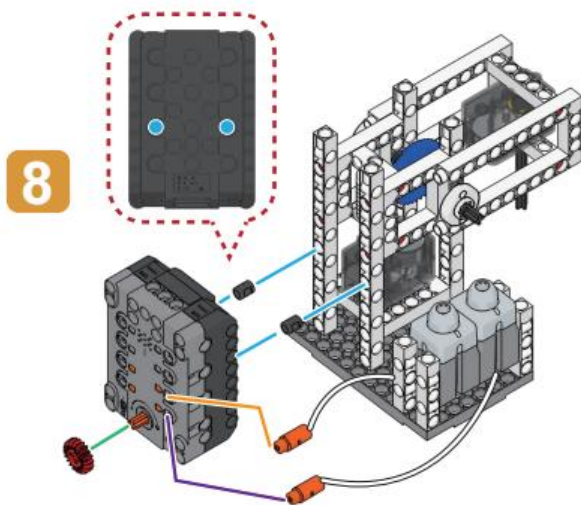
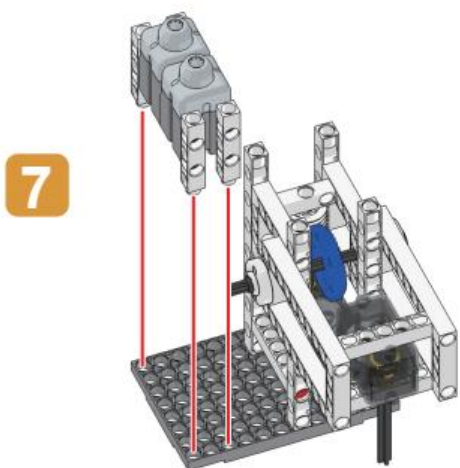
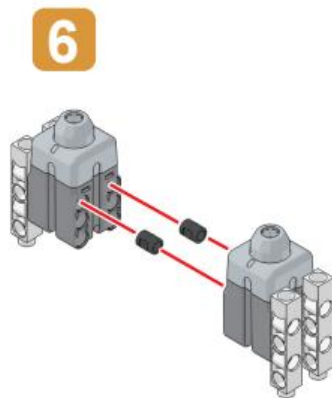
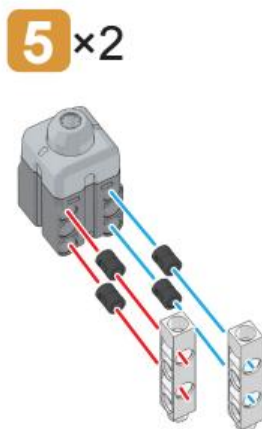
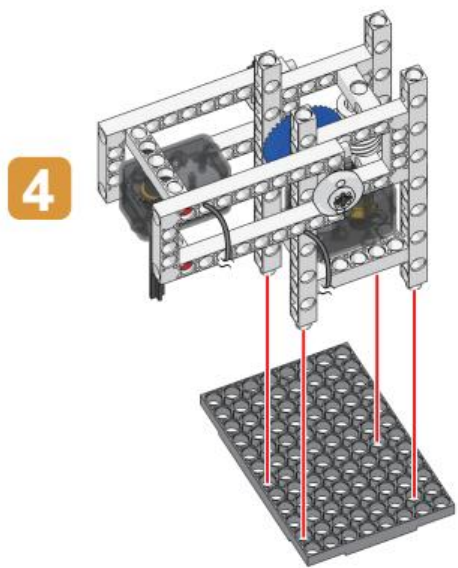
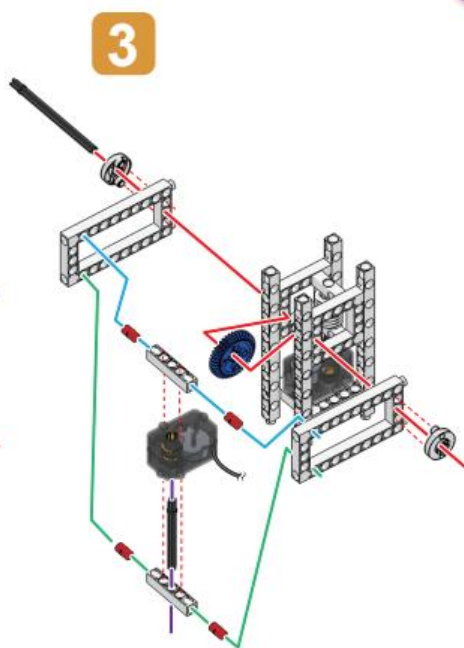
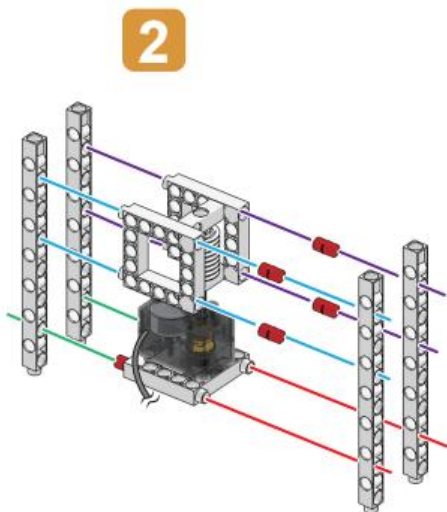
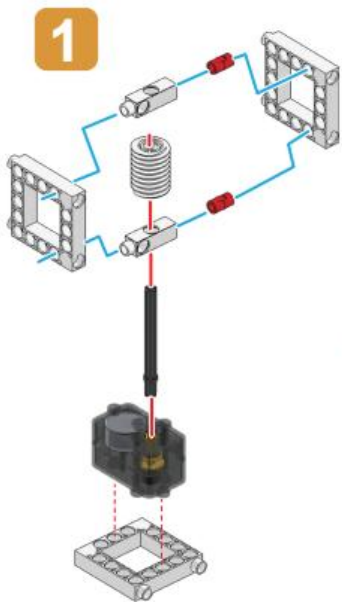
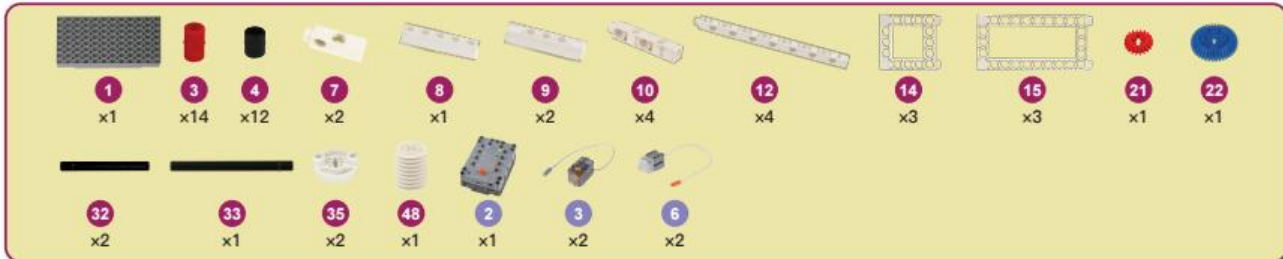

9

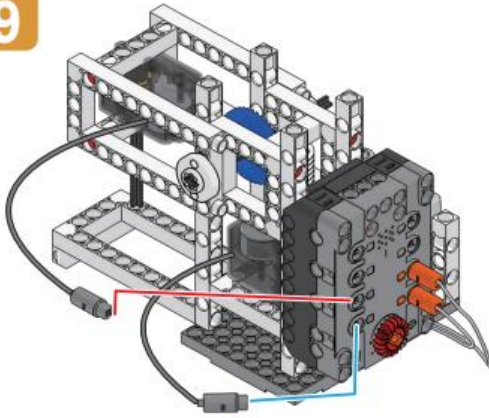

10

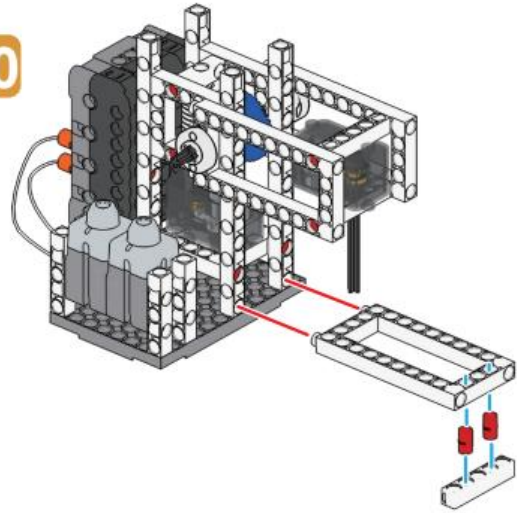

完成  
Done

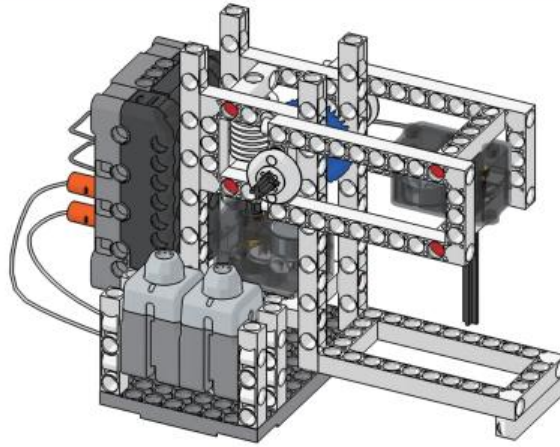

程式示例  
Program Example

```

repeat while true
do
  if get button 1 sensor data = 1
  do
    motor id 1
    direction clockwise
    speed 180
  else if get button 2 sensor data = 1
  do
    motor id 1
    direction counter-clockwise
    speed 180
  else if get knob sensor data > 50
  do
    motor id 2
    direction clockwise
    speed 345
  else
    motor id 1
    direction clockwise
    speed 0
    motor id 2
    direction clockwise
    speed 0
  
```

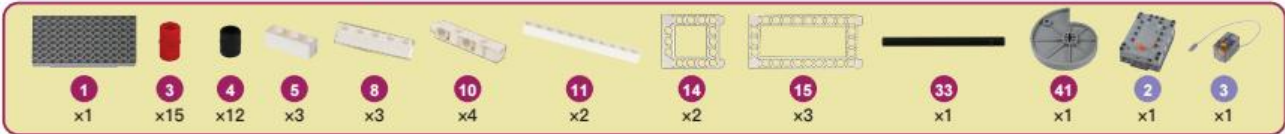

1

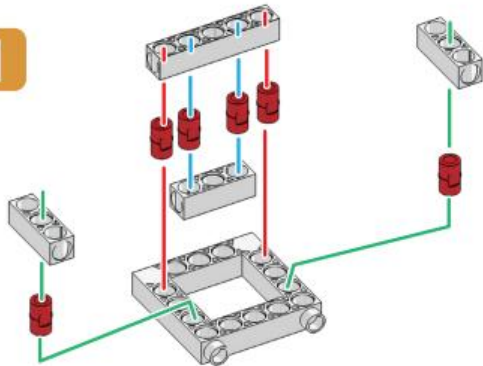

2

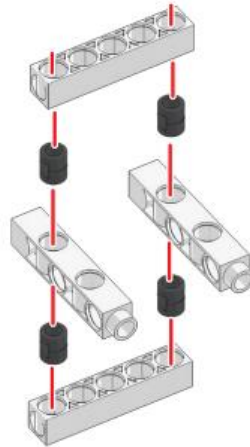

3

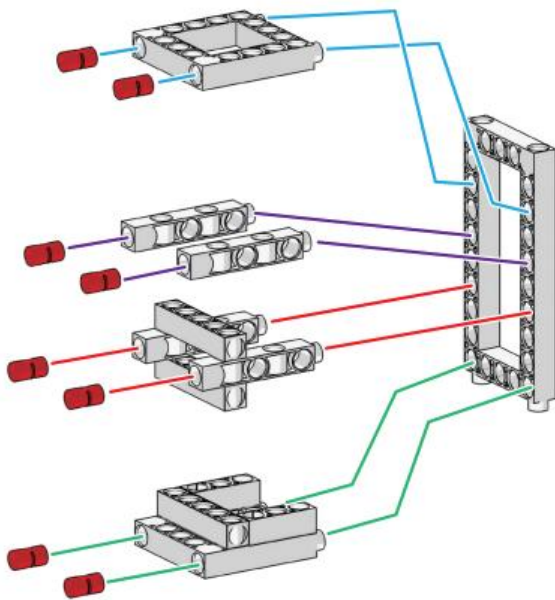

4

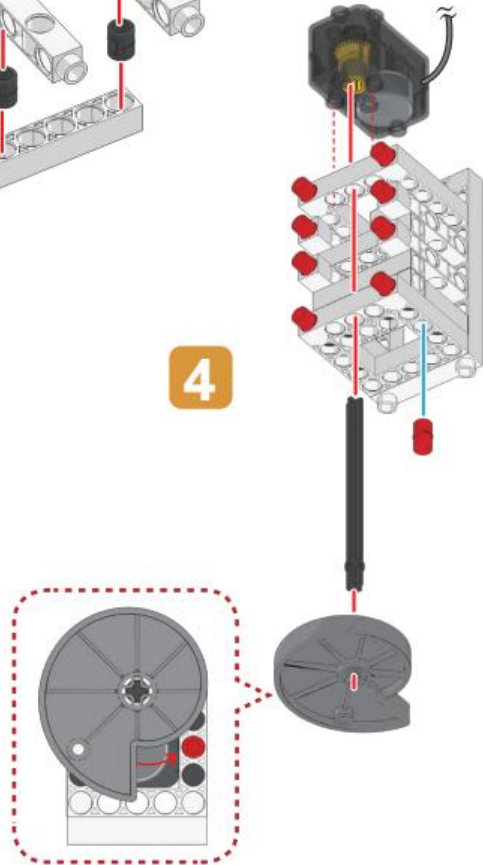

5

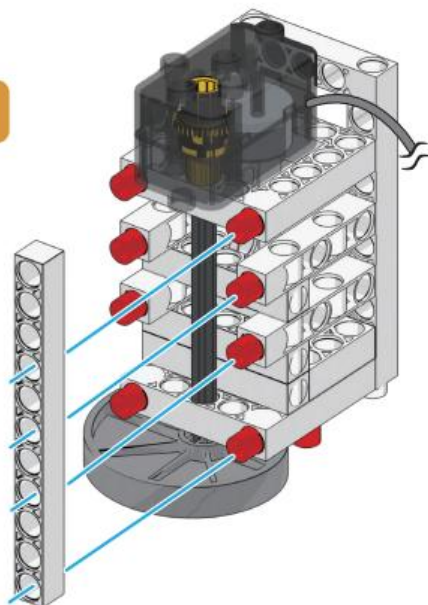

6

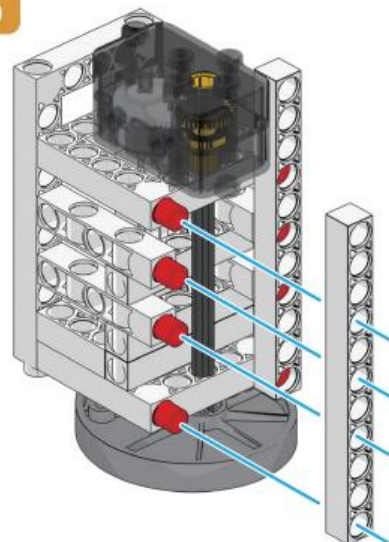

7

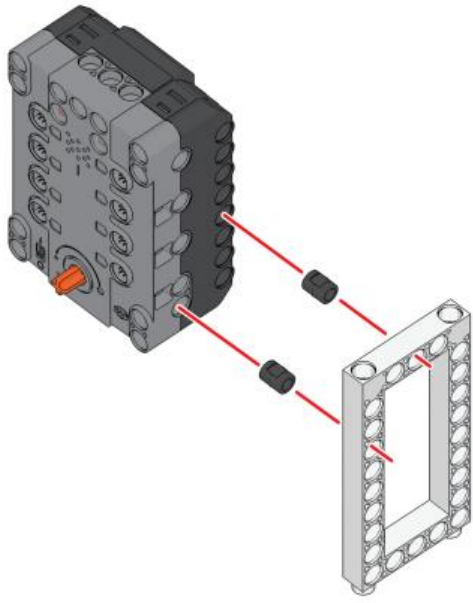

8

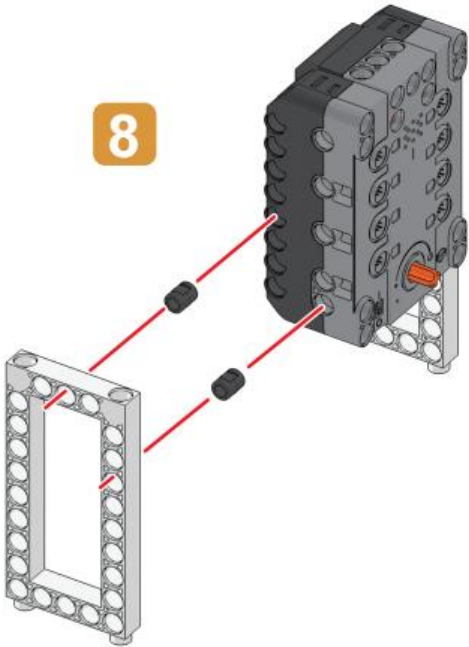

9

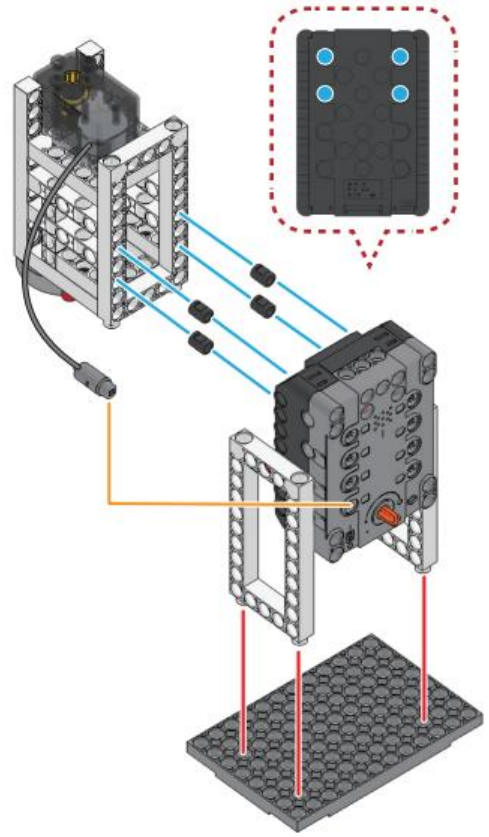

完成  
Done

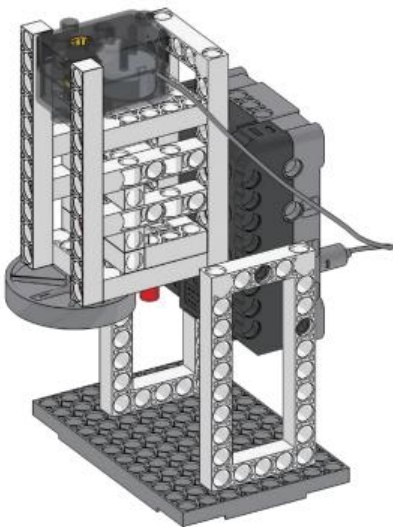

### 程式示例 Program Example

```

repeat while true
do
  if get microphone sensor data >= 220
  do
    repeat 5 times
    do
      motor id 1
      direction clockwise
      speed 345
      motor id 1
      direction counter-clockwise
      speed 345
      motor id 1
      direction clockwise
      speed 0
    else
      motor id 1
      direction clockwise
      speed 0
  
```



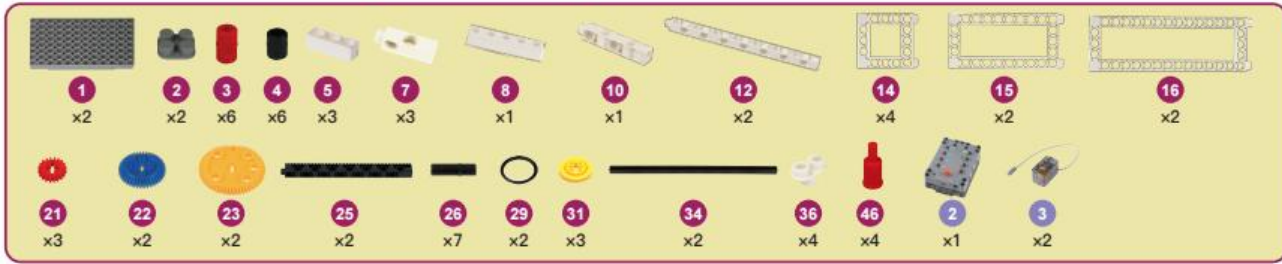

1

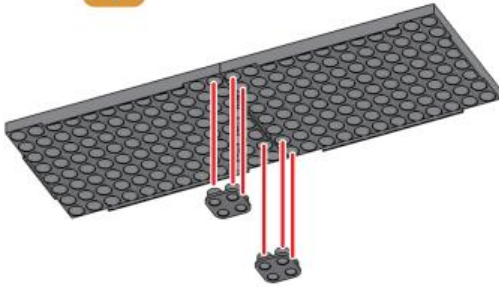

2

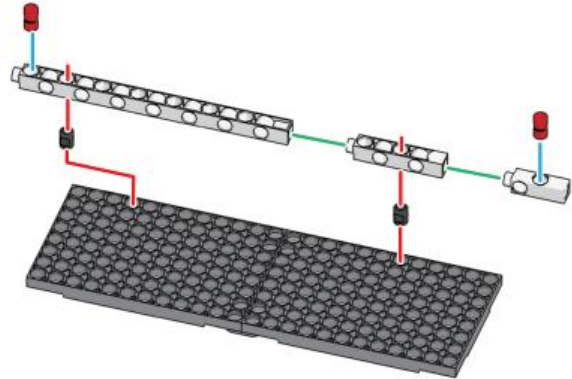

3

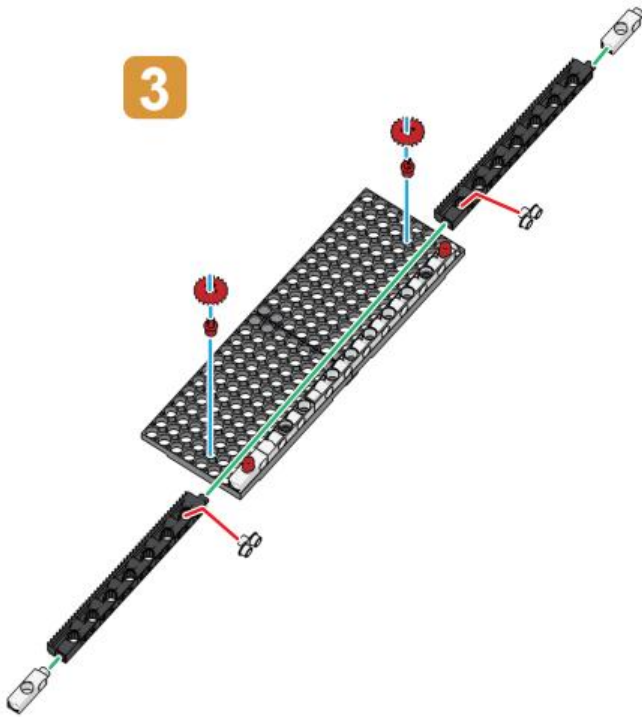

4

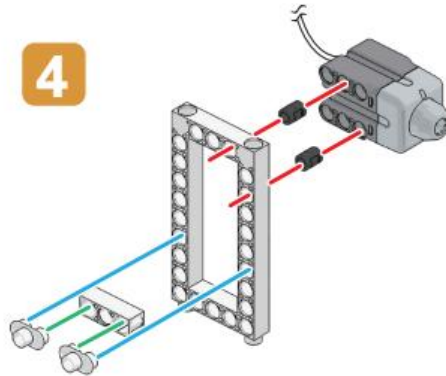

5



6

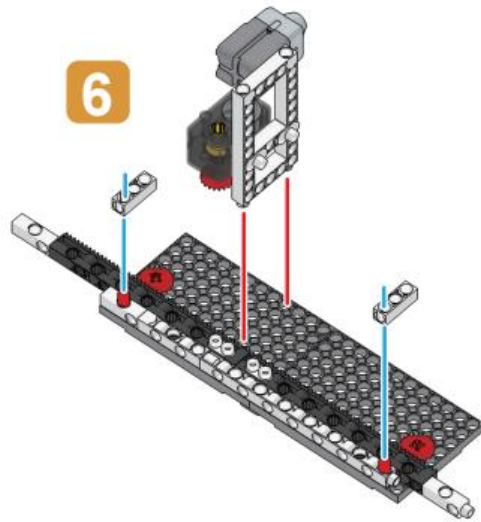

7

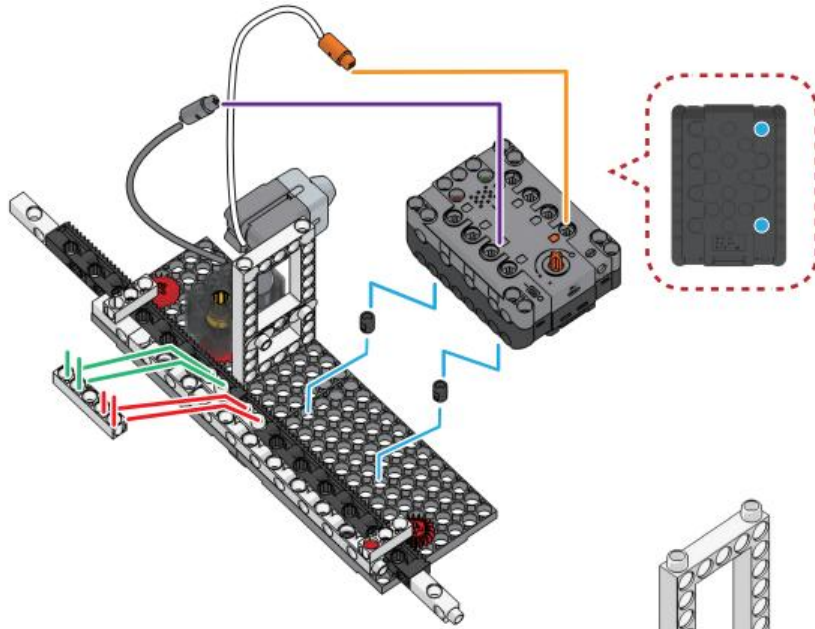

8

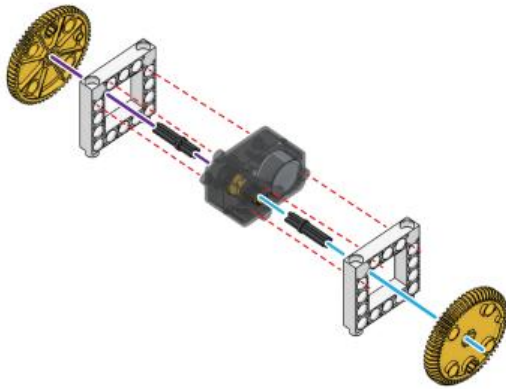

9

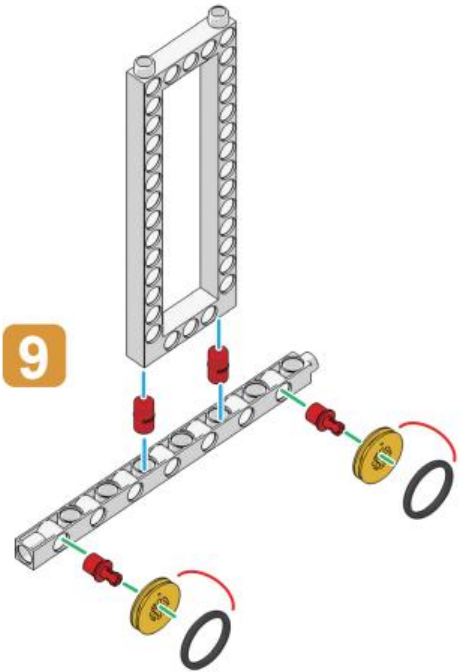

10

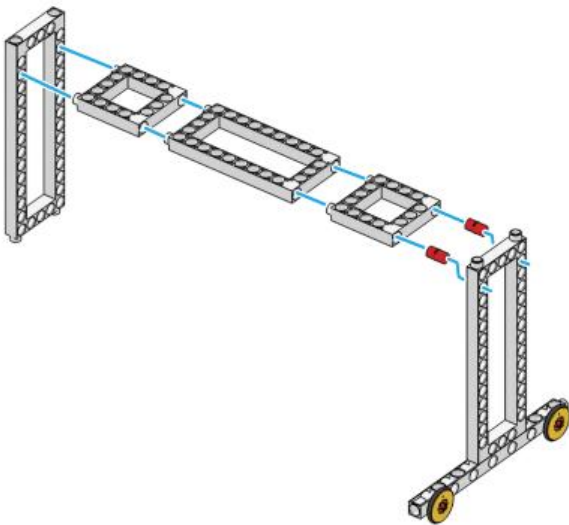

11

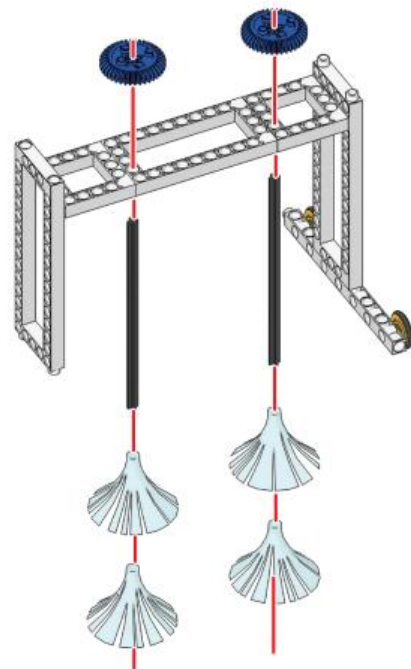

12

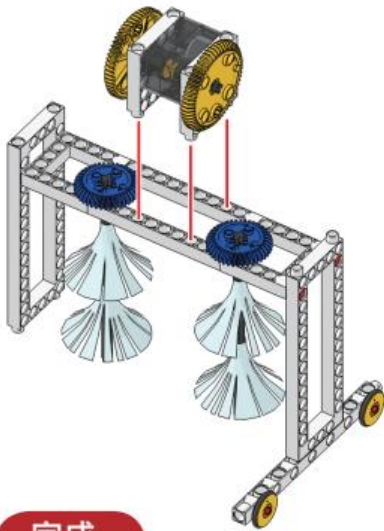

13

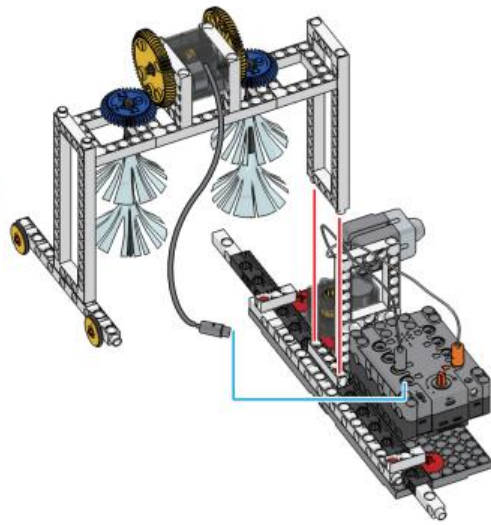

完成  
Done

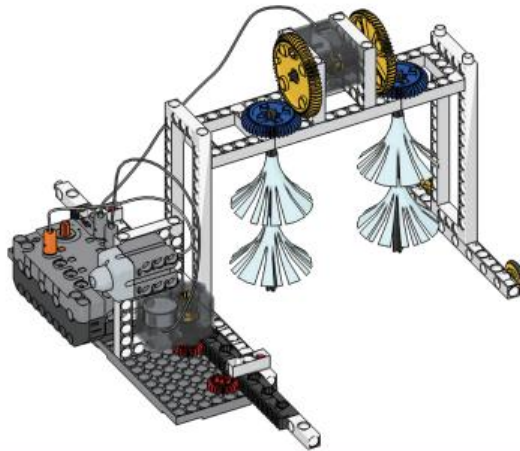

程式示例  
Program Example

```

repeat while true
do
  if get button 2 sensor data = 1
  do
    repeat 2 times
    do
      motor id 1
      direction clockwise
      speed 345
      repeat 3 times
      do
        motor id 2
        direction counter-clockwise
        speed 180
      repeat 3 times
      do
        motor id 2
        direction clockwise
        speed 180
      motor id 2
      direction clockwise
      speed 0
      motor id 1
      direction clockwise
      speed 0
    
```

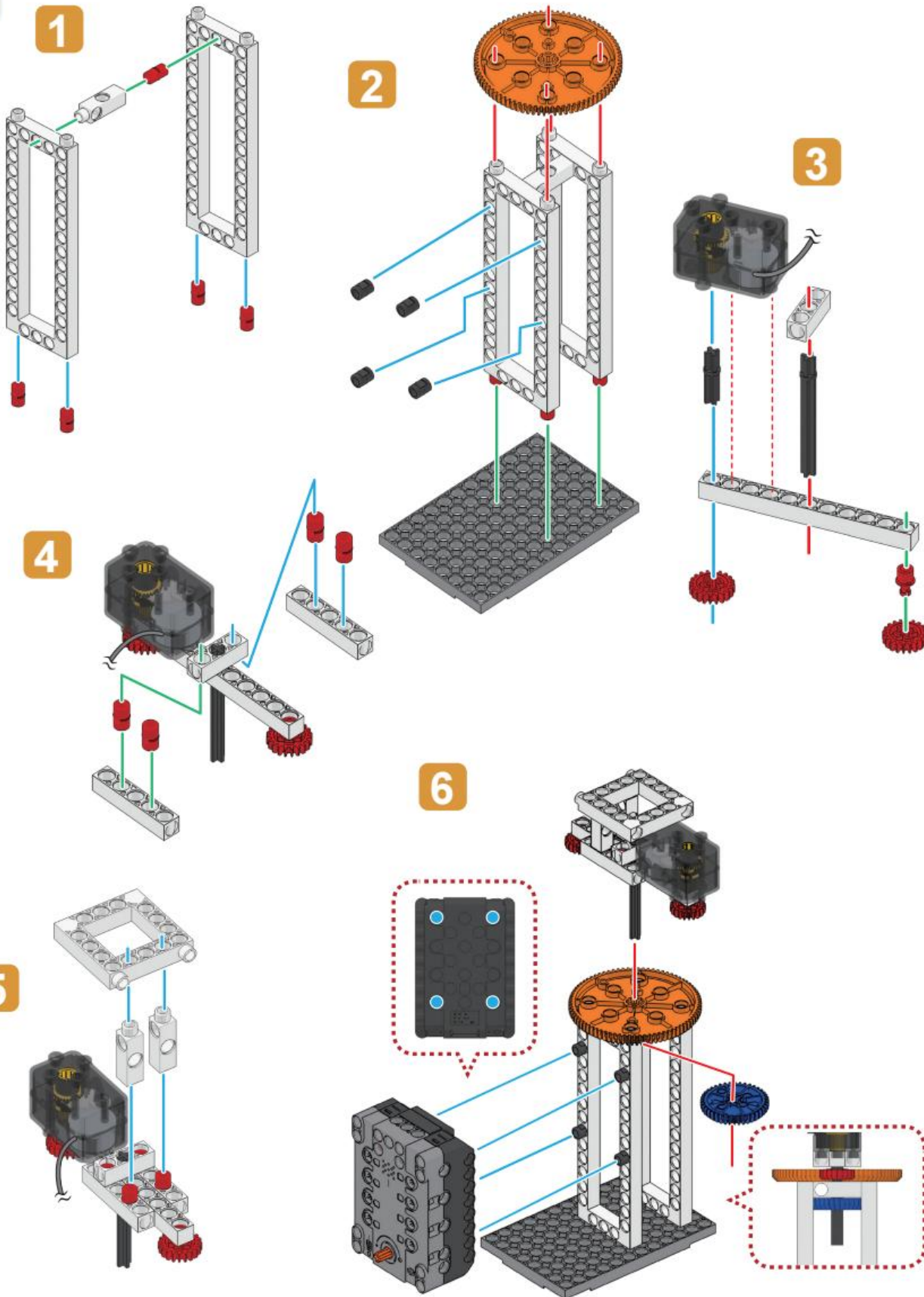
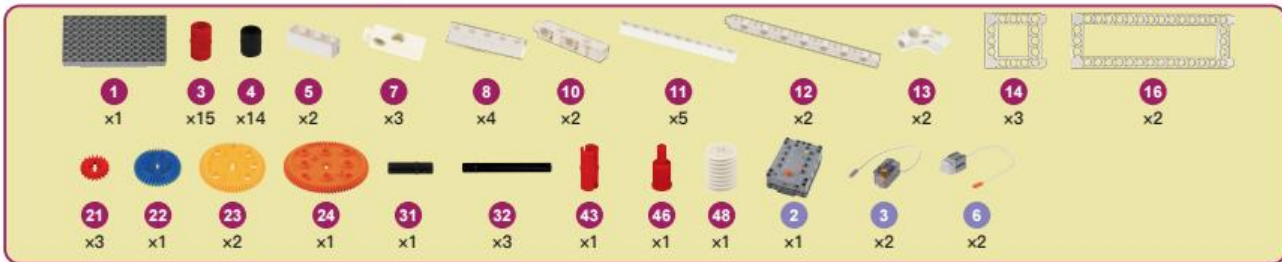

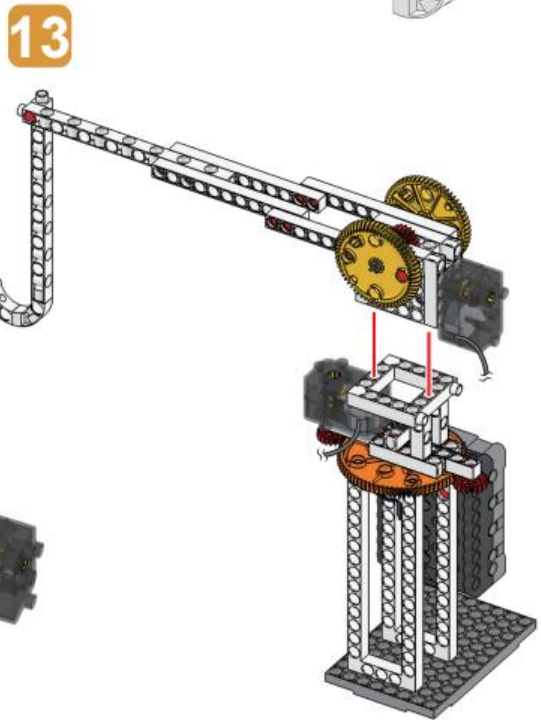
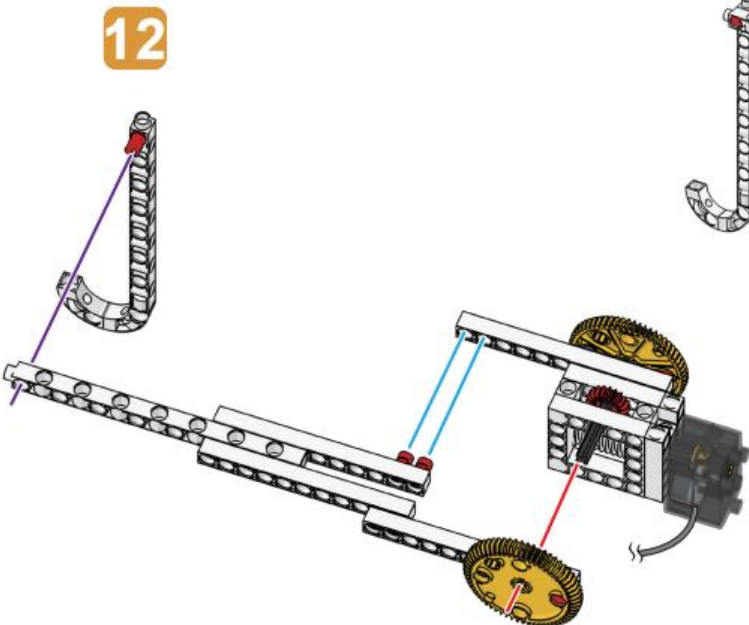
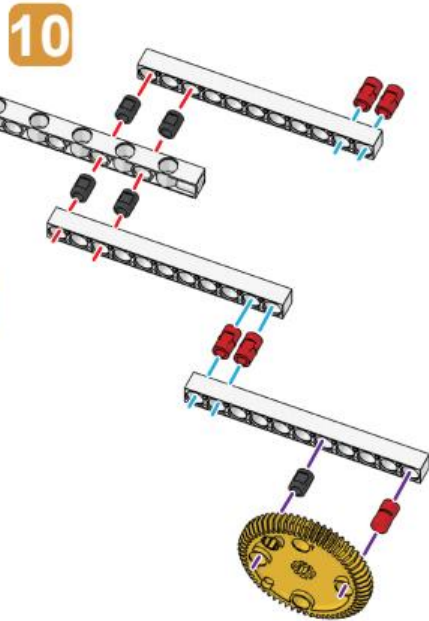
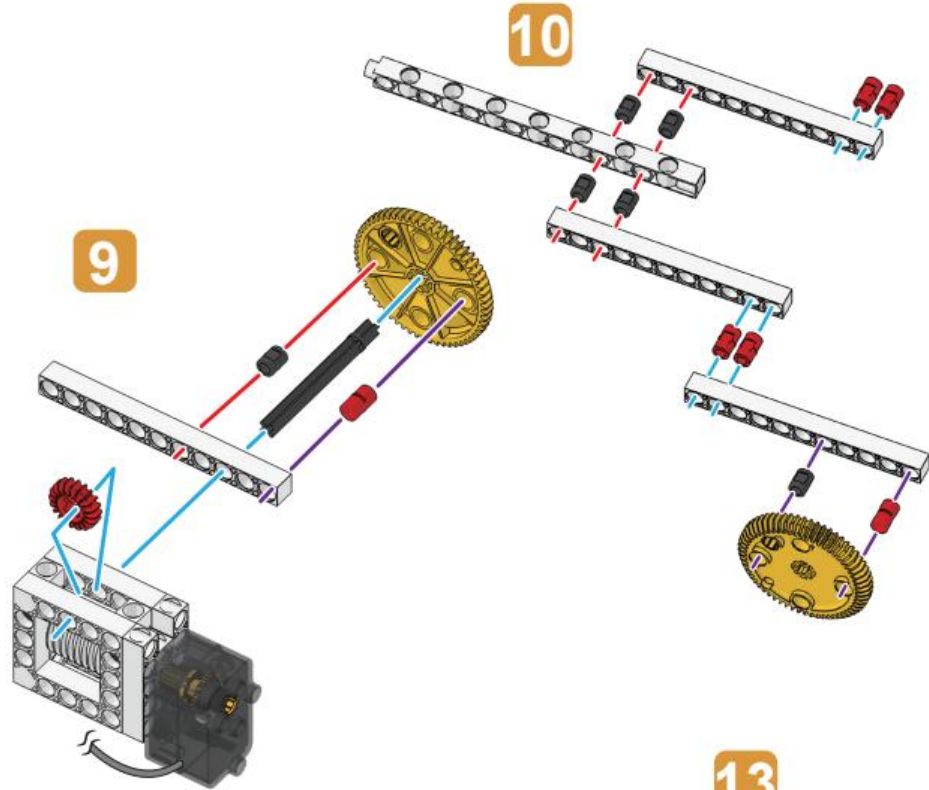
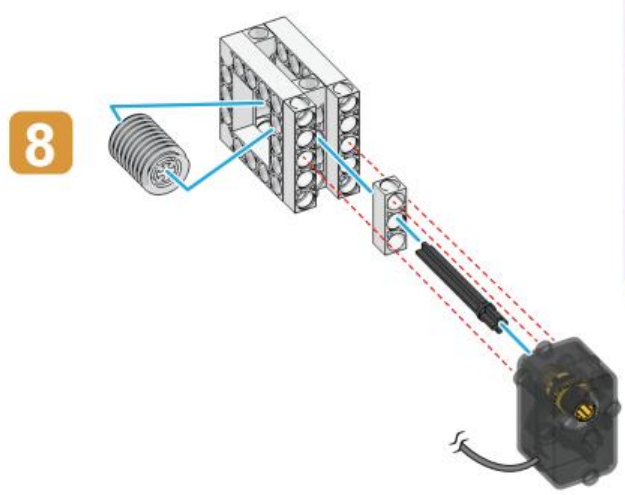
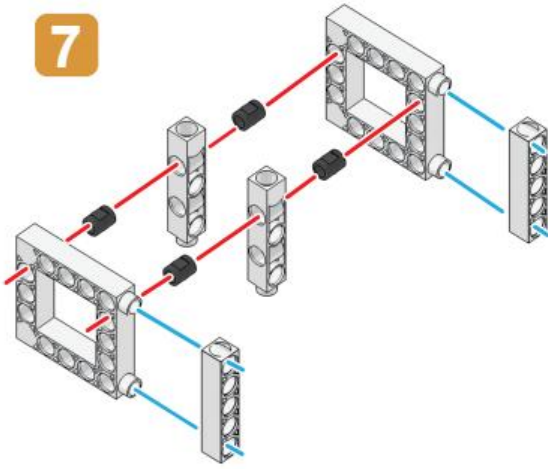

## 塔型吊車

## Tower Crane

14

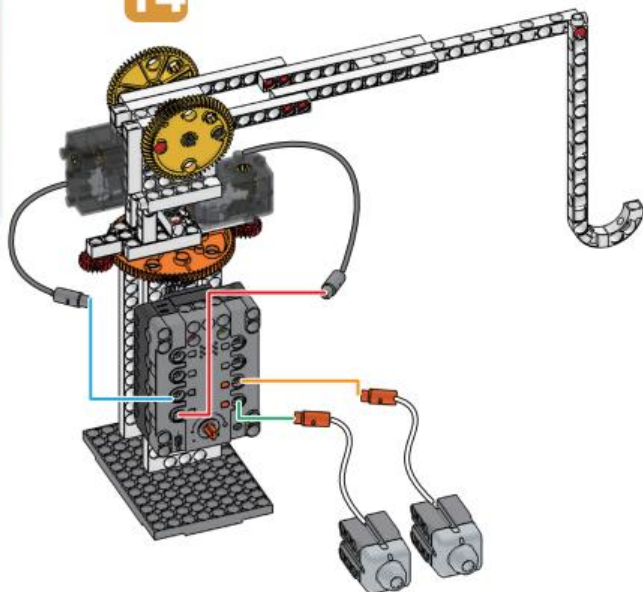

完成  
Done

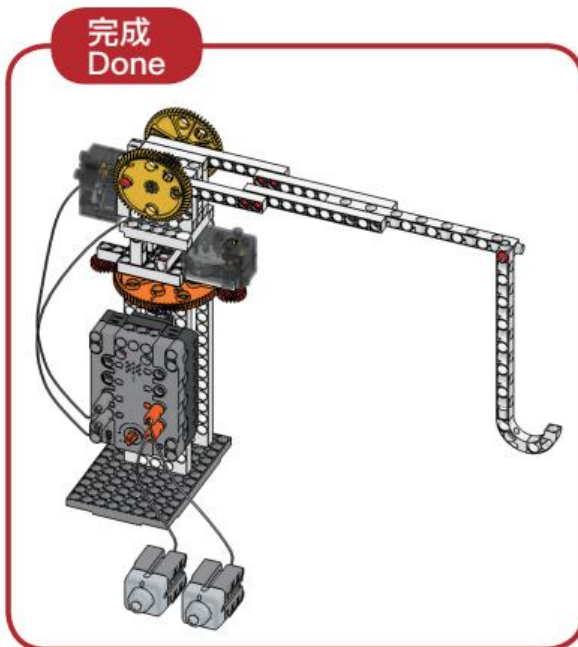

### 程式示例 Program Example

```

repeat while true
do
  if get button 1 sensor data = 1
  do
    repeat 2 times
    do
      motor id 1
      direction clockwise
      speed 180
    do
      motor id 1
      direction clockwise
      speed 0
    else if get button 2 sensor data = 1
    do
      repeat 2 times
      do
        motor id 1
        direction counter-clockwise
        speed 180
      do
        motor id 1
        direction counter-clockwise
        speed 0
    else if get button 1 sensor data = 1 and get button 2 sensor data = 1
    do
      repeat 5 times
      do
        motor id 2
        direction counter-clockwise
        speed 180
      repeat 5 times
      do
        motor id 2
        direction clockwise
        speed 180
    else
    do
      motor id 1
      direction clockwise
      speed 0
    do
      motor id 2
      direction clockwise
      speed 0
  
```

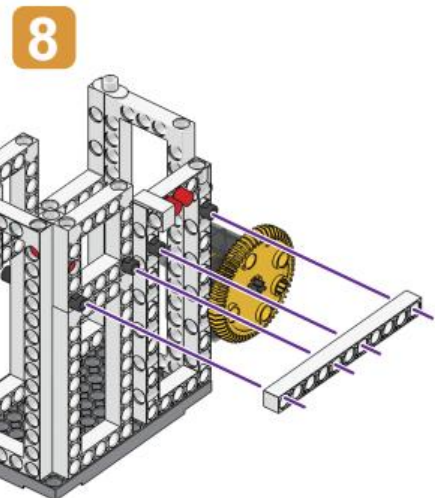
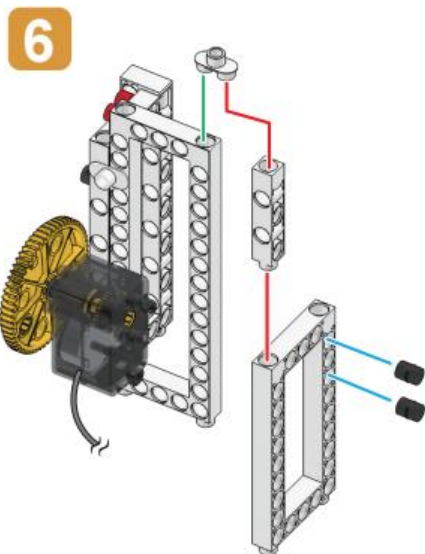
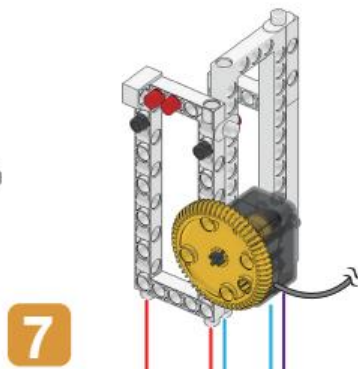
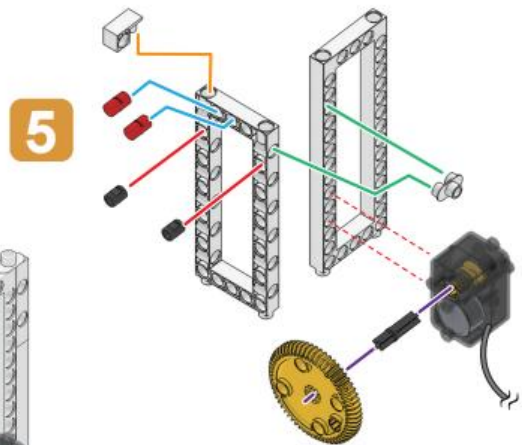
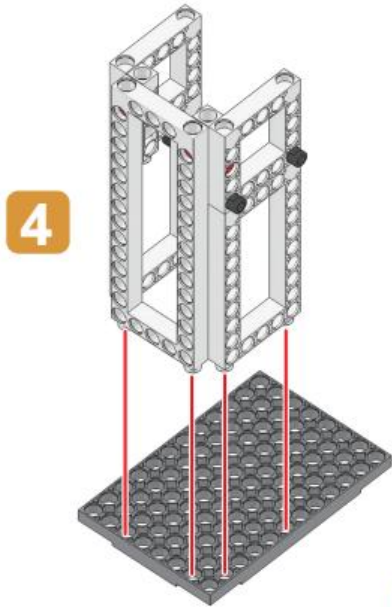
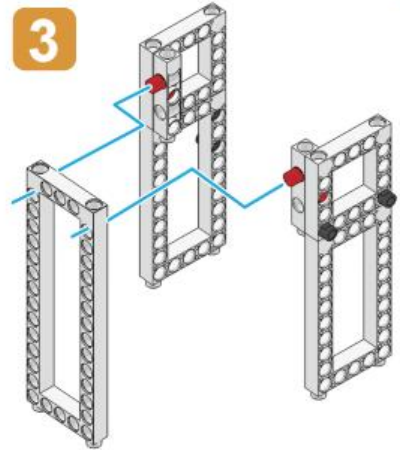
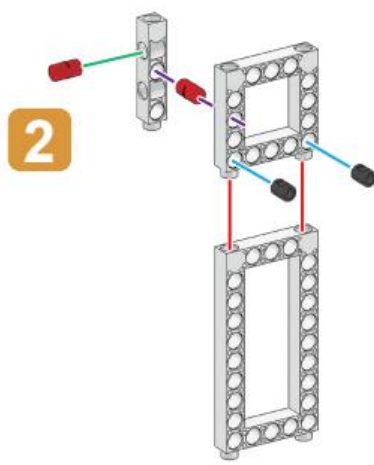
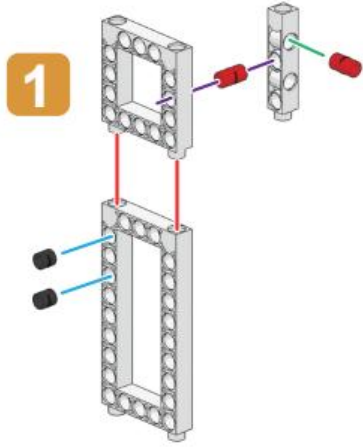
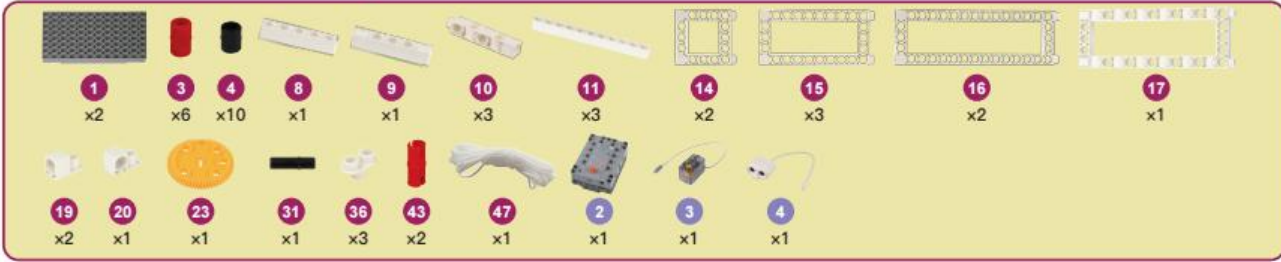

## 電子垃圾桶

## Automatic Trash Can

9

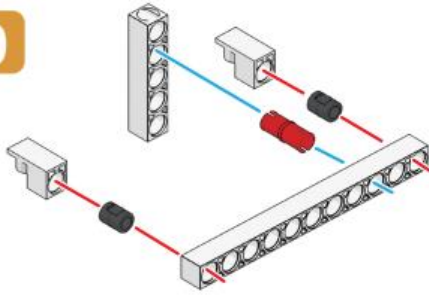

10

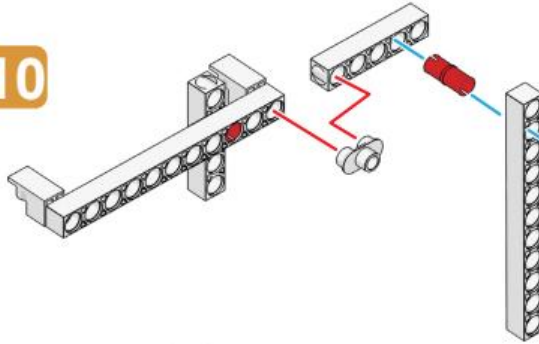

11

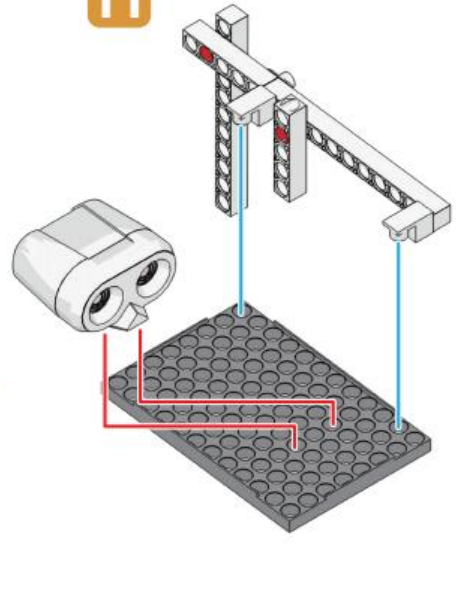

12

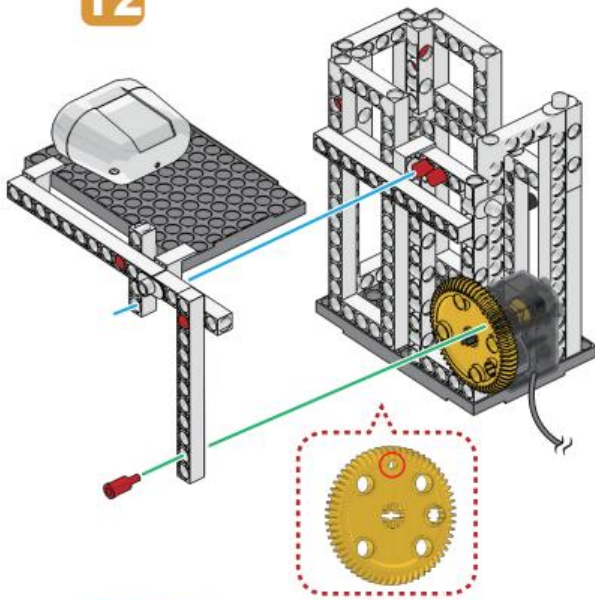

13

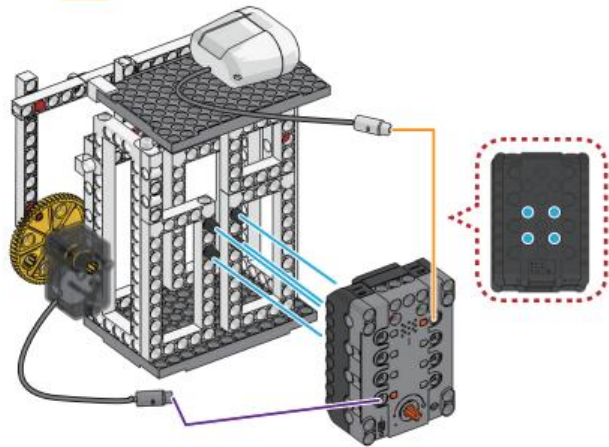

完成  
Done

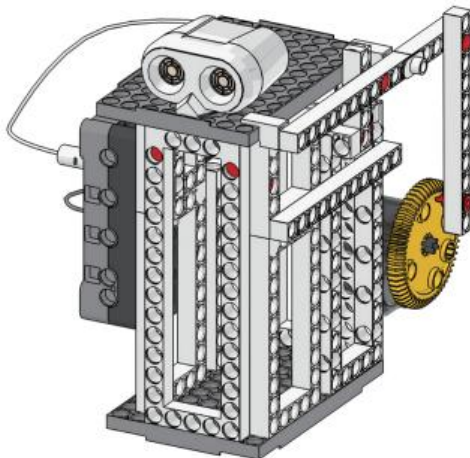

程式示例  
Program Example

```

repeat while true
do
  if get distance sensor data <= 20
  do
    repeat 2 times
    do
      motor id 1
      direction counter-clockwise
      speed 90
    else
      motor id 1
      direction clockwise
      speed 0
  
```



3	4	6	7	8	9	11	12	14	15	16
x12	x14	x2	x2	x2	x2	x1	x6	x4	x4	x4
17	26	31	32	36	43	45	2	3	4	
x1	x2	x1	x1	x2	x2	x1	x1	x1	x1	

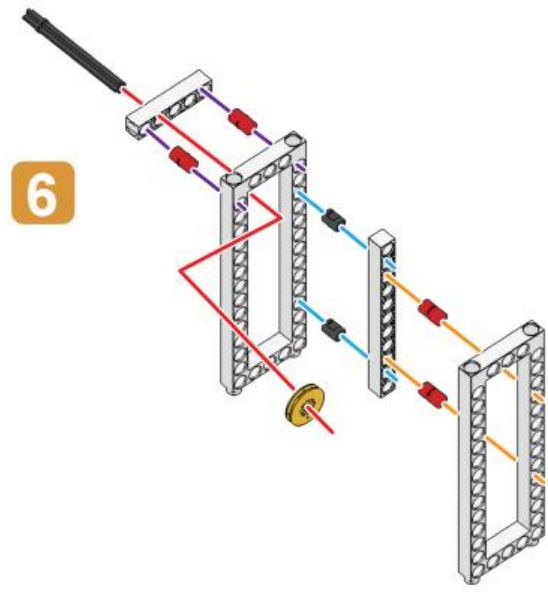
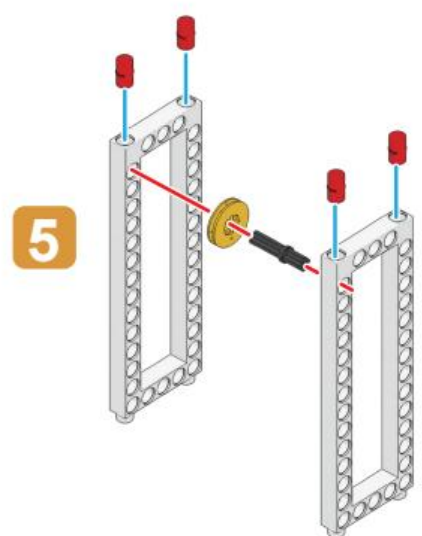
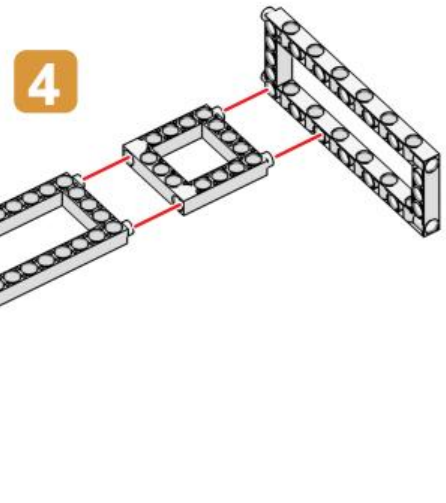
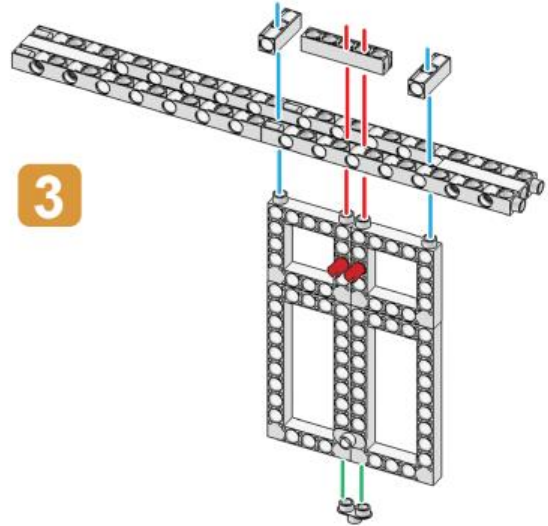
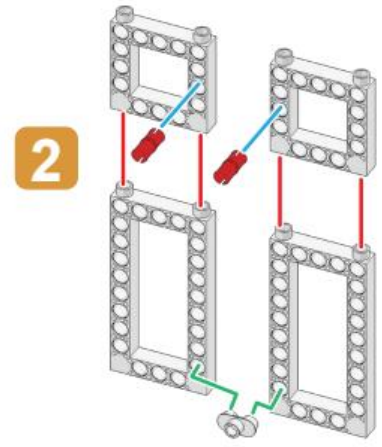
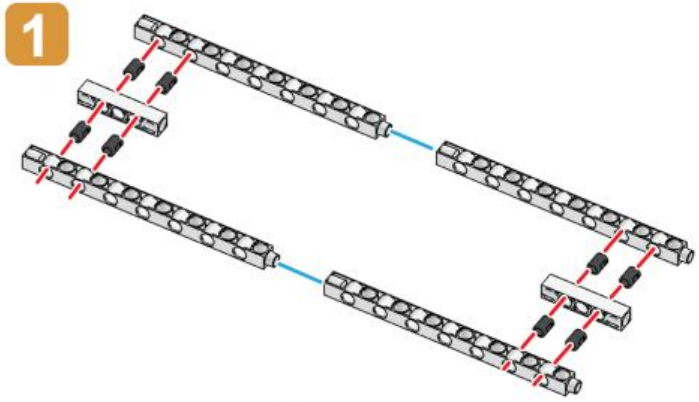

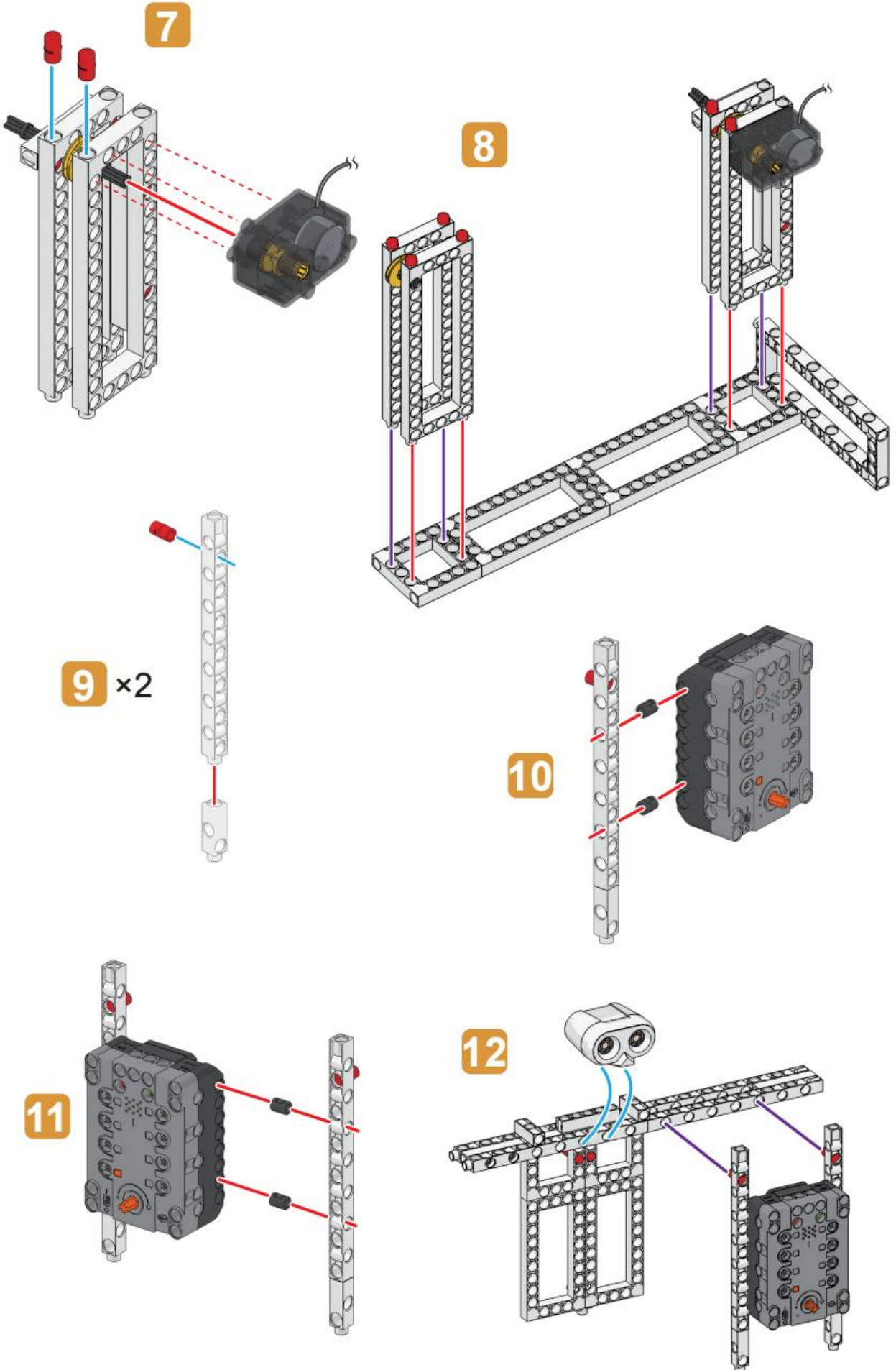

13

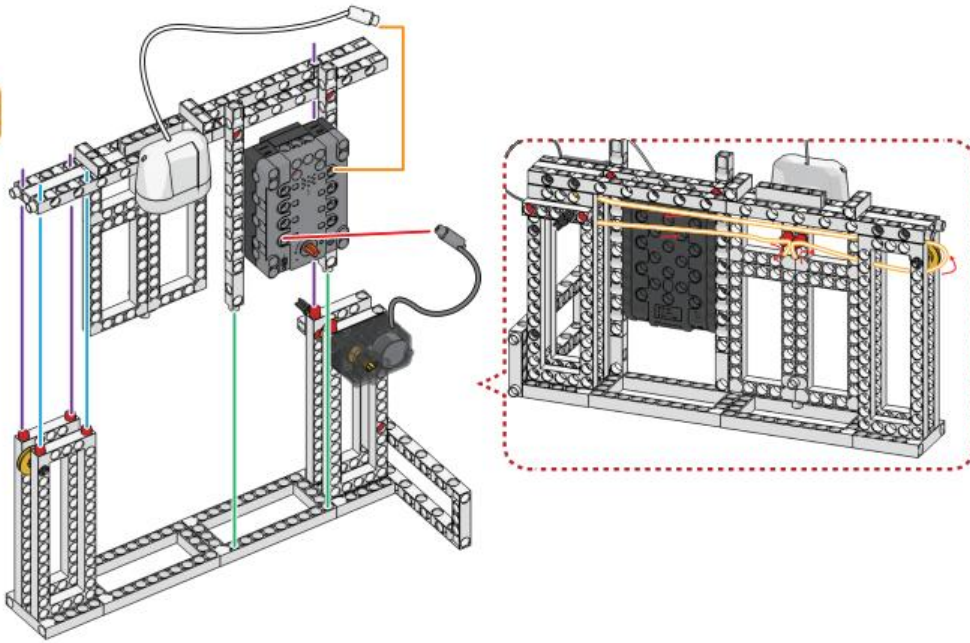

完成  
Done

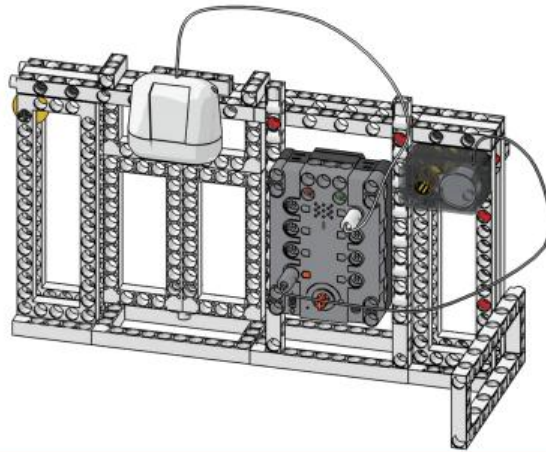

程式示例  
Program Example

```

repeat while true
do
  if get distance sensor data <= 5
  do
    play buzzer demo
    repeat 2 times
    do
      motor id 1
      direction clockwise
      speed 180
    repeat 2 times
    do
      motor id 1
      direction counter-clockwise
      speed 180
    else
      motor id 1
      direction clockwise
      speed 0
  
```

## 避障機械人

## Obstacle Avoiding Robot

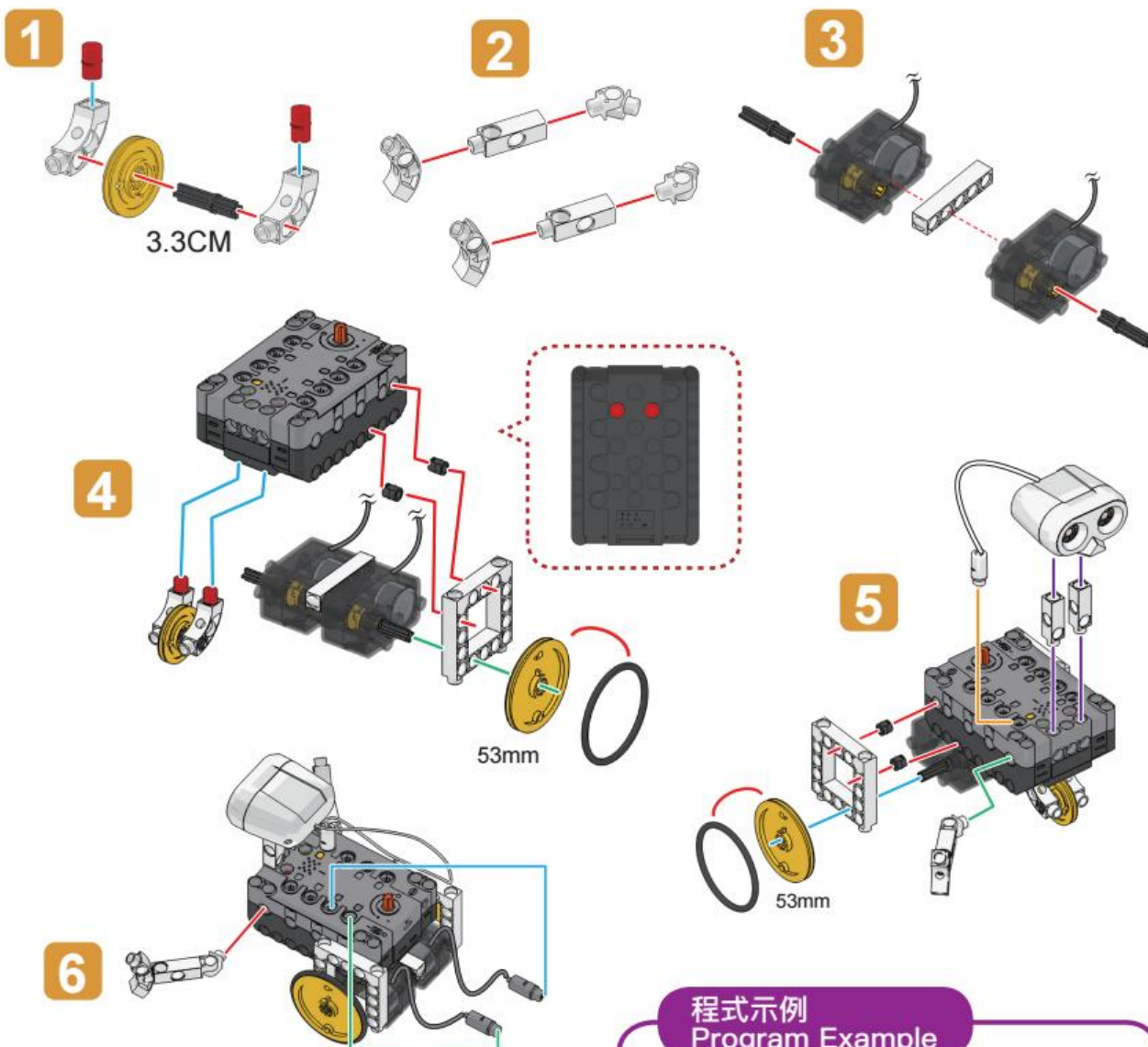
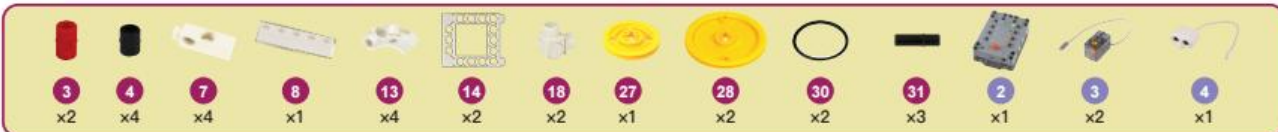

完成  
Done

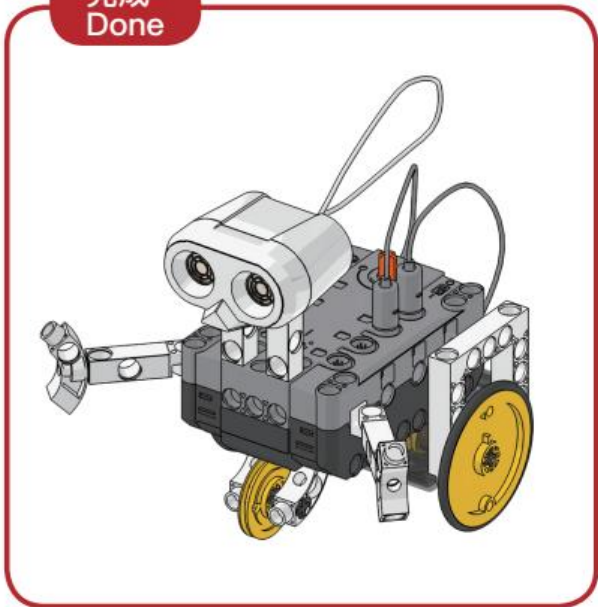

### 程式示例 Program Example

```

repeat while true
do
  if get distance sensor data >= 40
  do
    motor id 1
    direction counter-clockwise
    speed 90
    motor id 2
    direction counter-clockwise
    speed 90
  else
    motor id 1
    direction clockwise
    speed 135
    motor id 2
    direction counter-clockwise
    speed 135
  
```

3	4	8	10	11	14	15	16	21	22	24	31	32
x8	x14	x3	x2	x2	x4	x1	x2	x2	x1	x1	x2	x2
35	46	48	2	3	5							
x2	x1	x1	x1	x2	x1							

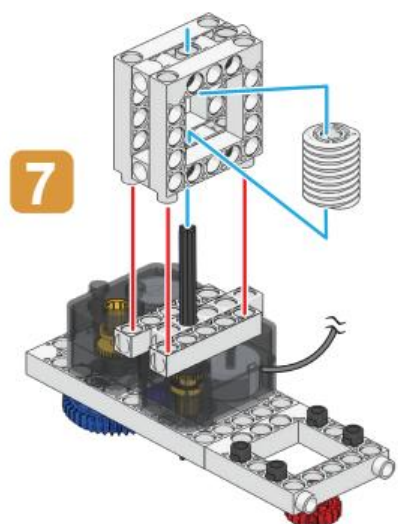
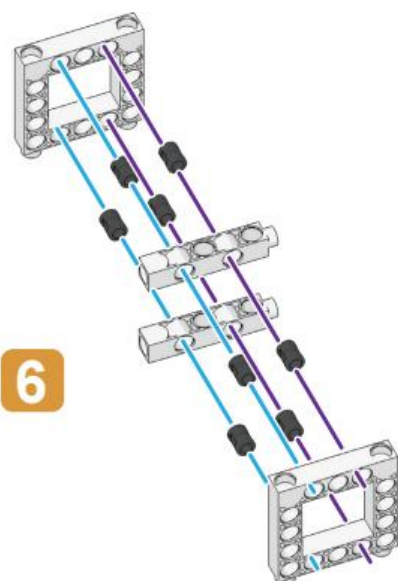
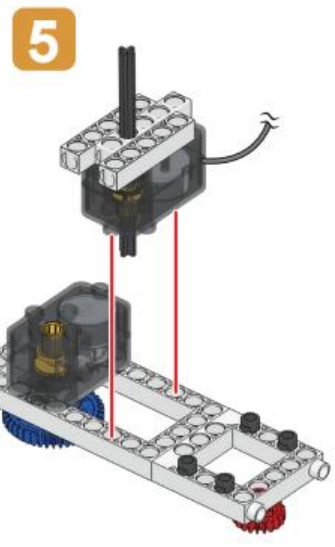
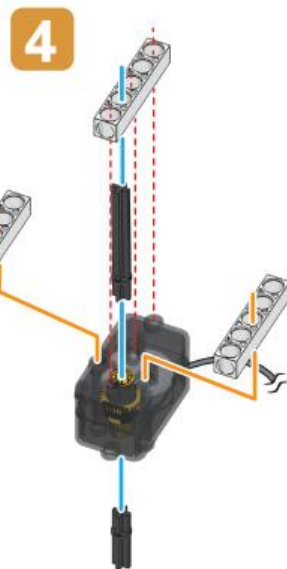
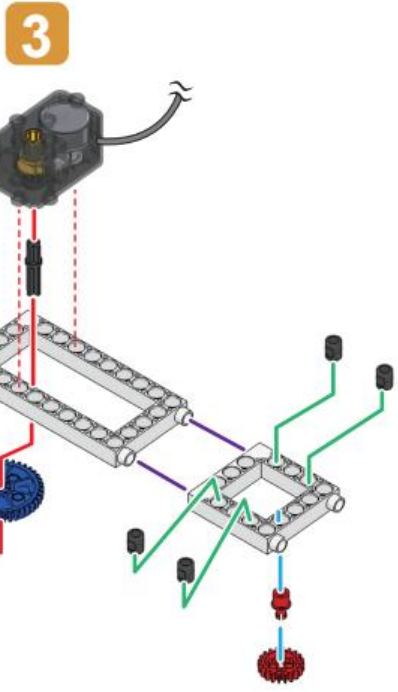
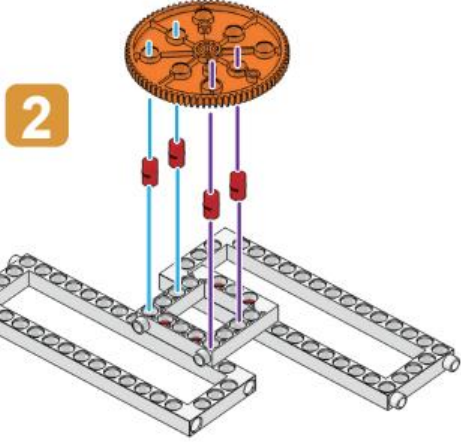
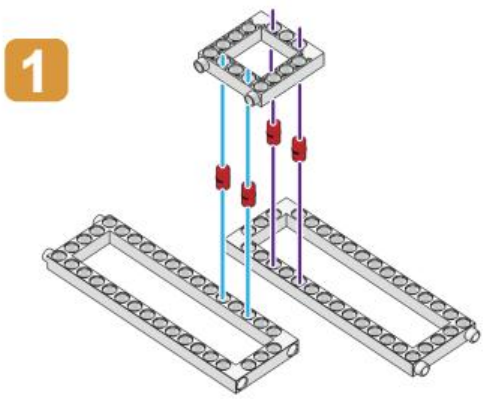

## 追光怪手

## Light - sensitive Excavator

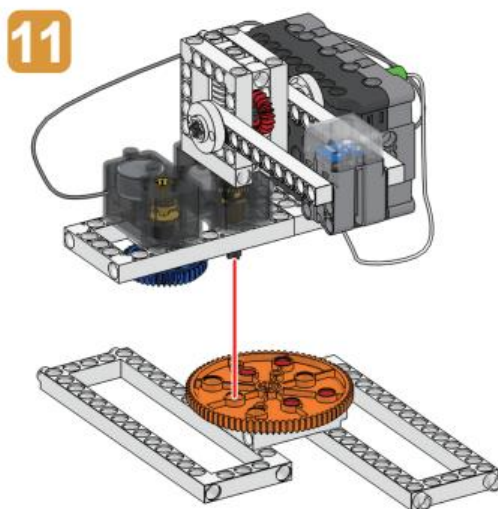
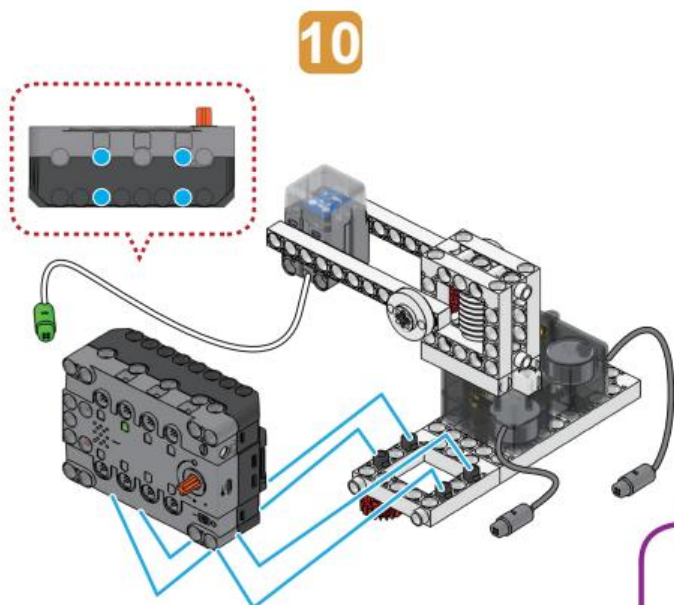
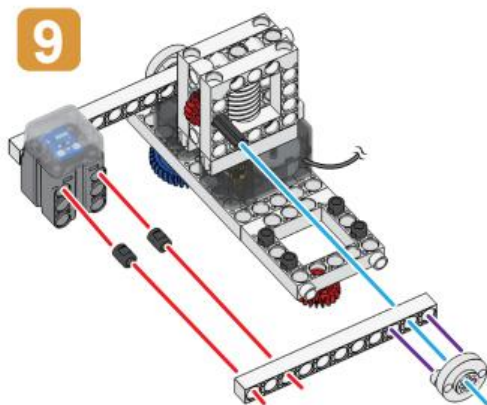
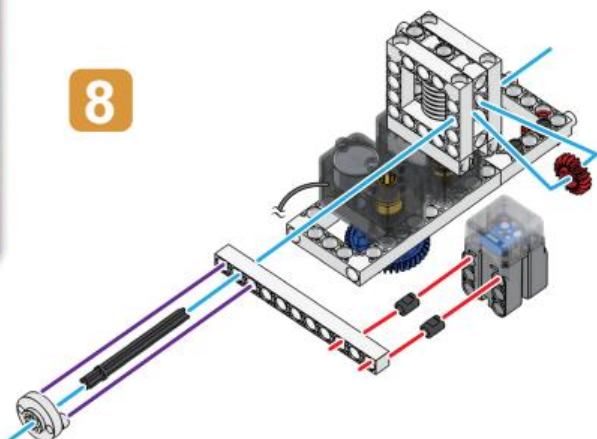

完成  
Done

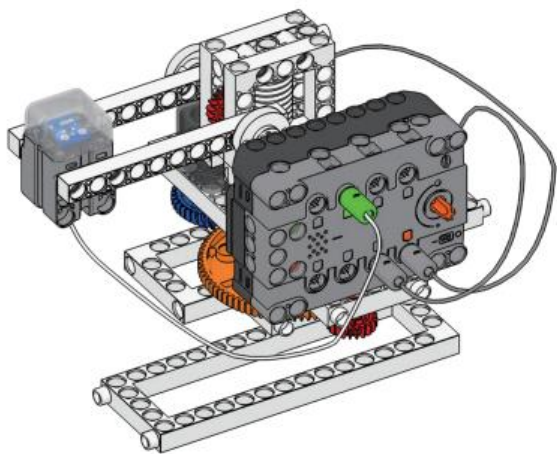

### 程式示例 Program Example

```

repeat until [get luminance sensor data > 900]
do
  set a to [get luminance sensor data]
  [motor id 2]
  direction clockwise
  speed 120
  set b to [get luminance sensor data]
  if a >= b
  do
    [motor id 1]
    direction counter-clockwise
    speed 180
  else if a < b
  do
    [motor id 1]
    direction clockwise
    speed 180
  [motor id 1]
  direction clockwise
  speed 0
  [motor id 2]
  direction clockwise
  speed 0
  
```

3	4	6	7	8	11	13	14	15	17	21	31
x10	x10	x4	x2	x4	x6	x4	x4	x1	x1	x2	x2

  

34	35	43	2	3	5	
x1	x2	x8	x1	x1	x1	

1

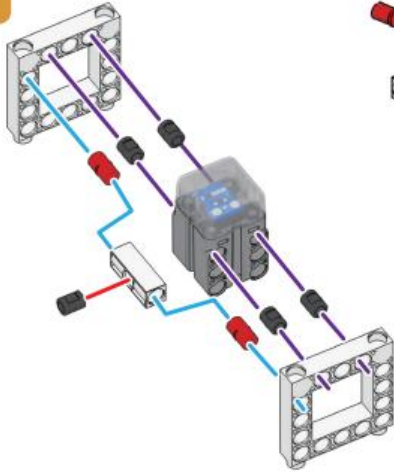

2

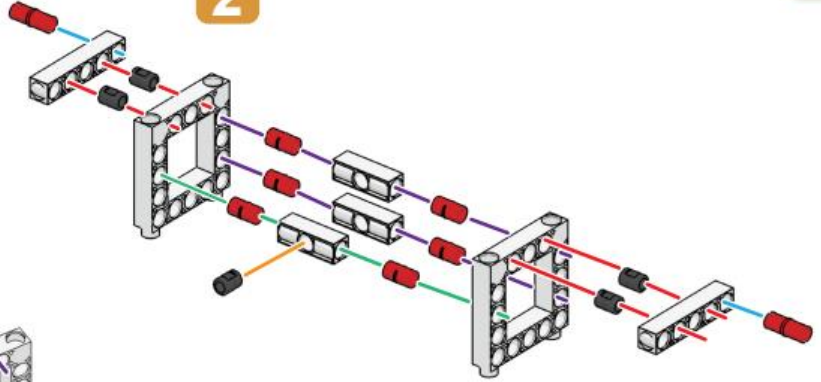

3

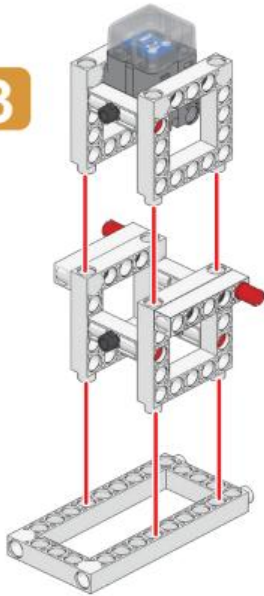

4

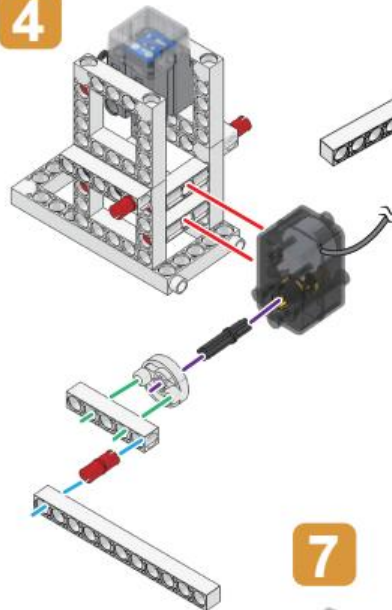

5

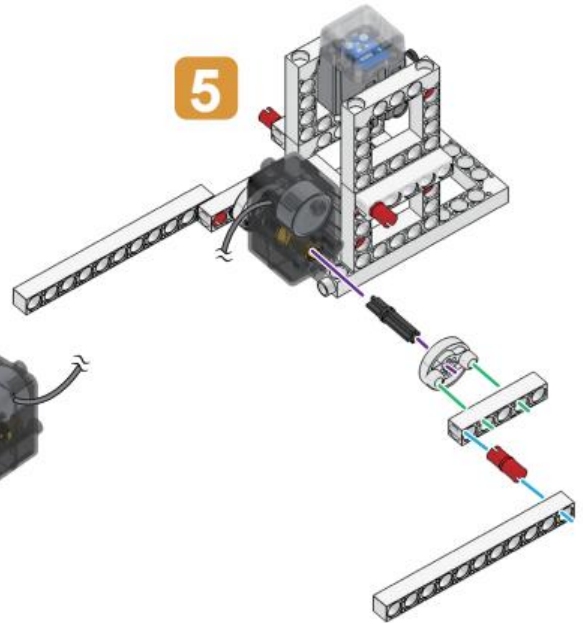

6

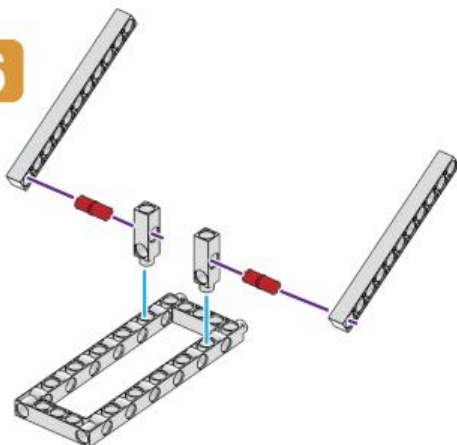

7

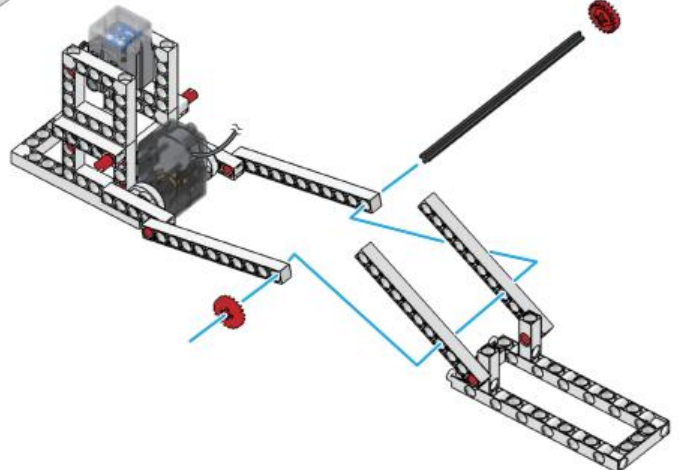

## 避光毛毛蟲

## Light - sensitive Caterpillars

8

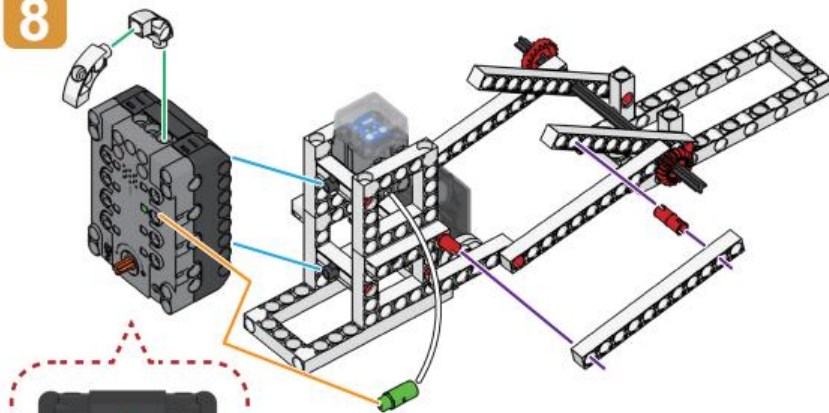

9

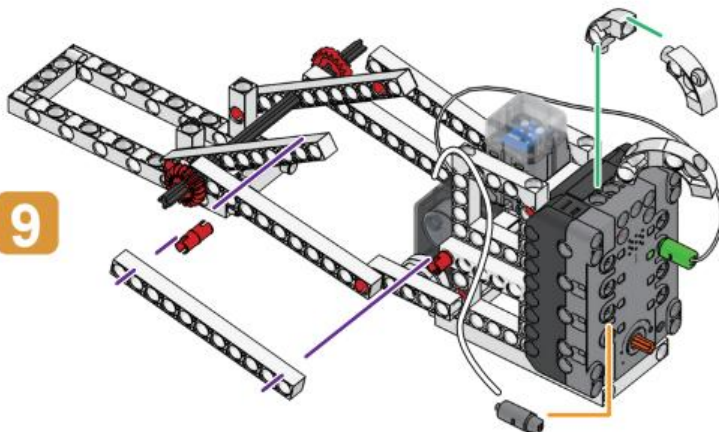

完成  
Done

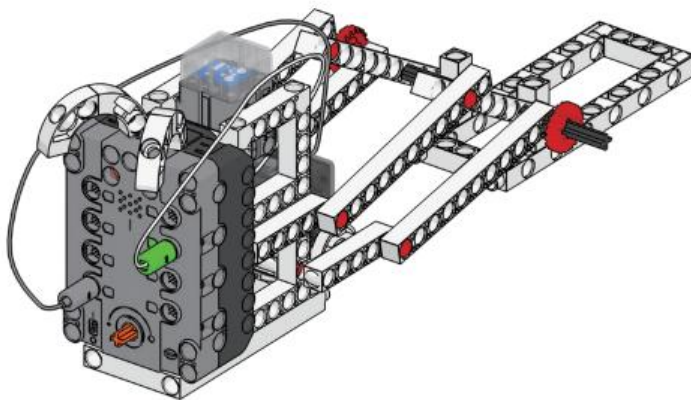

程式示例  
Program Example

```

repeat until [ ]
do
  if [get luminance sensor data < 100]
  do
    [motor id 1]
    direction clockwise
    speed 345
  else if [get luminance sensor data > 700 and get luminance sensor data < 700]
  do
    [motor id 1]
    direction clockwise
    speed 180
  [motor id 1]
  direction clockwise
  speed 0

```



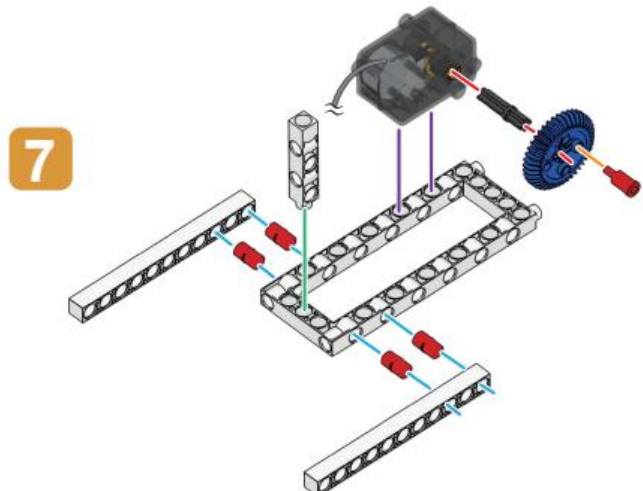
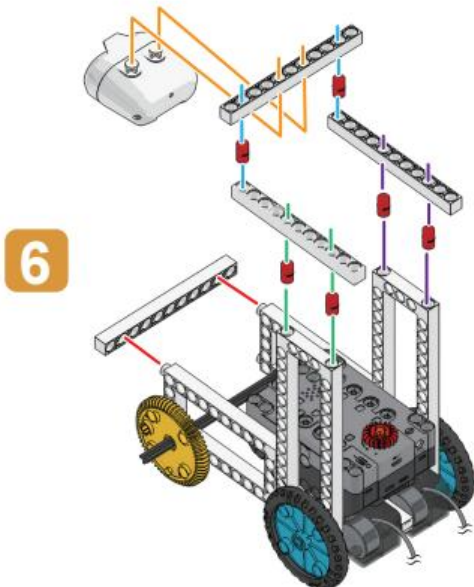
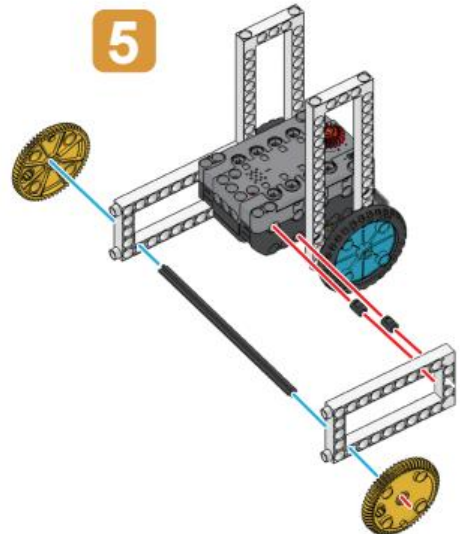
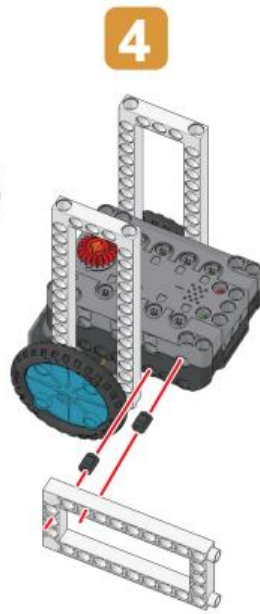
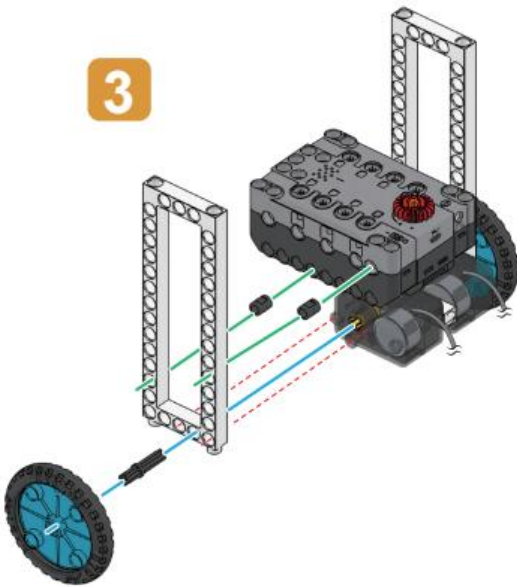
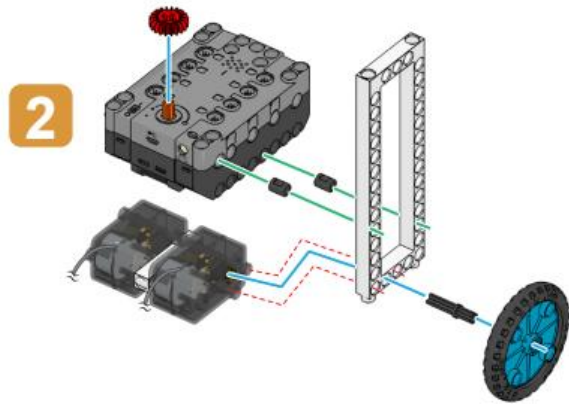
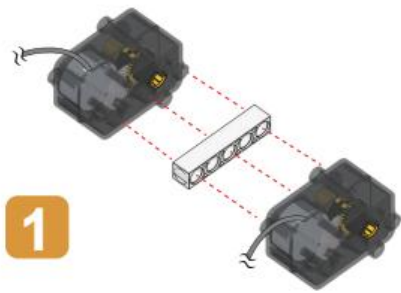
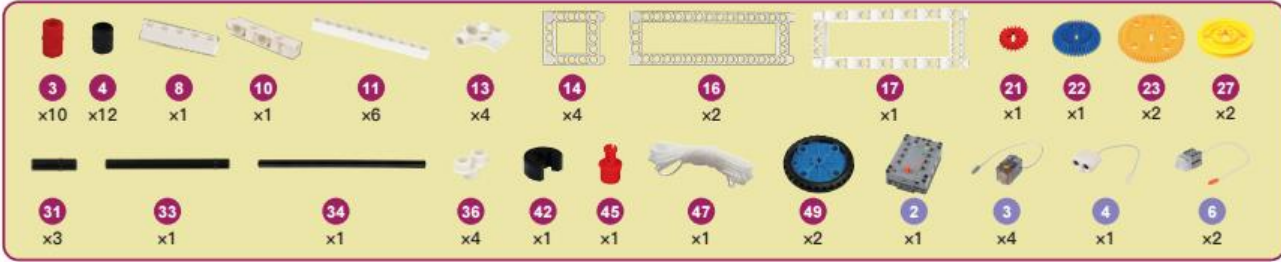

8

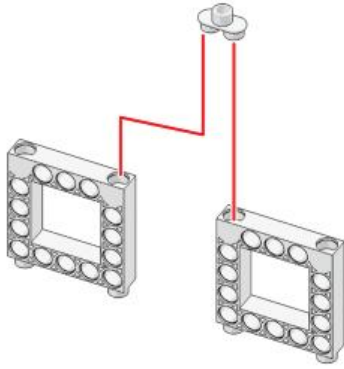

9

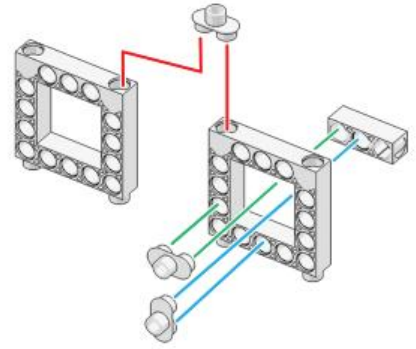

10

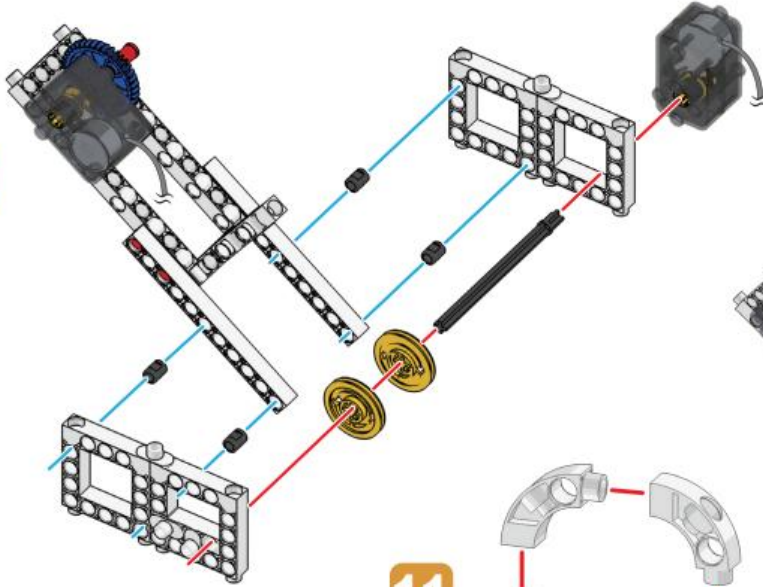

11

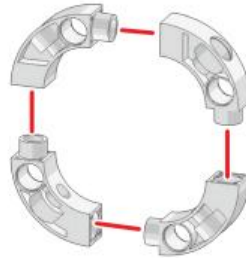

12

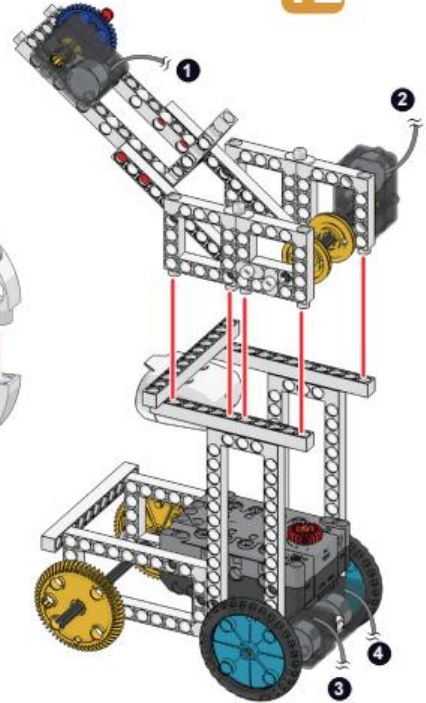

13

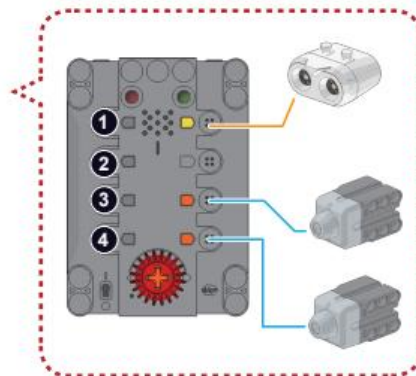
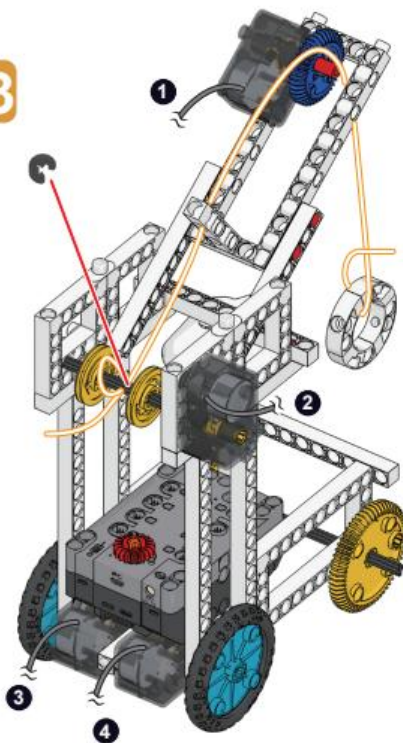

完成  
Done

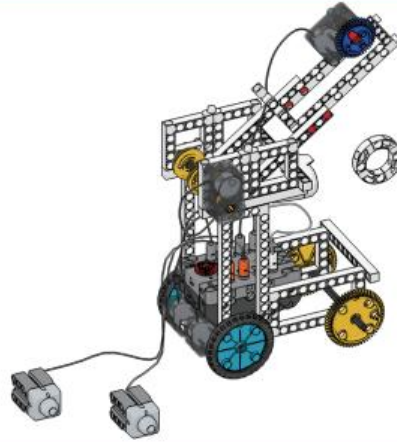

程式示例  
Program Example

```

repeat while true
do
  if
    get button 1 sensor data == 1 and
    get button 2 sensor data == 1
  do
    motor id 1
    direction clockwise
    speed 180
    motor id 1
    direction clockwise
    speed 180
  else if
    get button 1 sensor data == 1
  do
    motor id 1
    direction clockwise
    speed 0
    motor id 2
    direction clockwise
    speed 90
  else if
    get button 2 sensor data == 1
  do
    motor id 1
    direction clockwise
    speed 90
    motor id 2
    direction clockwise
    speed 0
  else if
    get distance sensor data < 20
  do
    repeat 2 times
    do
      motor id 3
      direction clockwise
      speed 180
    motor id 3
    direction clockwise
    speed 0
    repeat 10 times
    do
      motor id 4
      direction clockwise
      speed 180
    motor id 4
    direction clockwise
    speed 0
    repeat 2 times
    do
      motor id 3
      direction counter-clockwise
      speed 180
    motor id 3
    direction clockwise
    speed 0
  else
    motor id 1 direction clockwise 0
    motor id 2 direction clockwise 0
    motor id 3 direction clockwise 0
    motor id 4 direction clockwise 0

```

# FUN LAB



#1260  
創意積木組  
CREATIVE CUBE



#1261  
科學探索組  
SCIENTIFIC TOUR



#1270  
趣味機關組  
FUN WITH MECHANISM



#1262  
電學補充包  
ELECTRICITY KIT



#1264  
氣動補充包  
PNEUMATICS  
KIT



#1265  
風力補充包  
WIND POWER KIT



#1266  
水力補充包  
HYDRAULICS  
KIT



#1267  
太陽能補充包  
SOLAR POWER  
KIT

**GENIUS TOY TAIWAN CO., LTD.**  
[www.gigotoys.com](http://www.gigotoys.com) MADE IN TAIWAN  

© 2017 Genius Toy Taiwan Co., Ltd. All right reserved  
R21#1268